

P200 Pressure Regulator

- Minimize Sudden Downstream Load Change
- Wide Pressure Ranges
- P202 has internal relief valve for overpressure protection

The P200 series pressure regulator is a manual, direct acting, self-operating, spring loaded, adjustable regulator. The P200 series is used in applications where pressure reduction is required. The regulator will reduce the risk of “shock” from abrupt changes of downstream conditions. This can help prevent safety equipment from shutting an operation down.

Applications

- Compressors
- Gas Engines
- Service Regulators



Materials of Construction

Adjusting Screw	Aluminum / Zinc Plated Steel
Body	Ductile Cast Iron or WCB Steel
Bonnet	Aluminum
Closing Cap	Aluminum / Brass
Diaphragm	Nitrile
Lower Casing	Aluminum
Molded Seat Assembly	Nitrile
Orifice	Aluminum
Upper/Lower Spring Seat	Aluminum / Brass
Flange	Ductile Iron / WCB Steel

Specifications

Maximum Inlet	See Table 1	
Maximum Emergency Outlet	15 PSIG	
Pressure Ranges	See Table 2	
Port Sizes	1.25 NPT	
	1.5 NPT	
	1.5 NPT x 2 NPT	
	2 NPT	
Orifice Sizes	1/4"	
	3/8"	
	1/2"	
	3/4"	
	1"	
	1-3/16"	
End Connections	NPT	
	150 RF Flange	Steel Units Only
	125 FF Flange	Iron Units Only
Temperature Range	-20 °F to 180 °F	
	-29 °C to 82 °C	
Approx. Weight	26 lbs. (11.8 kg)	

P200 Series Maximum Inlet Pressure

Orifice Inches	Range	Maximum Inlet Pressure	
		PSIG	BAR
1/4"	Any	125	8.618
3/8"	Any	125	8.618
1/2"	Any	100	6.894
3/4"	Any	60	4.136
1"	2-4.5" thru 14-30" WC	25	1.723
	1-2 thru 4-10 PSIG	30	2.068
1-3/16"	2-4.5" thru 14-30" WC	13	0.896
	1-2 thru 1.5-3.25 PSIG	14	0.965
	2-5 thru 2-5.5 PSIG	20	1.378
	4-10 PSIG	25	1.723

P200 Series Range Springs

Model	Spring Ranges		Spring Color	Part Number
	W.C. or PSI	Bar		
P201 P202 P201S P202S	2 - 4.5 WC	0.005 - 0.011	Brown	655-697-002
	3.5 - 6.5 WC	0.009 - 0.016	Red	655-697-003
	5 - 9 WC	0.012 - 0.022	Black	655-697-004
	6 - 14 WC	0.015 - 0.035	Purple	655-697-011
	8.5 - 18 WC	0.021 - 0.045	White	655-697-005
	14 - 30 WC	0.035 - 0.075	Dark Green	655-697-006
P201H P202H P201S P202S	1 - 2 PSIG	0.069 - 0.138	Dark Blue	655-697-007
	1.5 - 3.25 PSIG	0.103 - 0.224	Orange	655-697-008
	2 - 5 PSIG	0.138 - 0.345	Yellow	655-697-009
P201K P201S	2 - 5.5 PSIG	0.138 - 0.379	Green	655-659-003
	4 - 10 PSIG	0.276 - 0.689	Grey	655-697-010

P200 Regulator Rebuild Kits

	Kit Includes	Part Number
P200 O & H Ranges	Diaphragm, disk holder assembly, cap gasket and body/lower casing o-ring	971-200-000
P200 K Ranges	Diaphragm, disk holder assembly, cap gasket and body/lower casing o-ring	971-200-001
P200 All Units	Stabilizer Kit for Downstream Dampening	971-200-004

P200 Dimensions

Body Size	A			B	C	D		
	Inches	NPT	125 FF Flange			150 RF Flange	NPT	125 FF Flange
1.25	6.13			11.03	18.09	1.85		
1.5	6.13		10	11.03	18.09	1.85		1.85
1.5 x 2	6.13			11.03	18.09	1.85		
2	6.13	10	10	10.59	17.66	2.15	3	3

P200 Standard

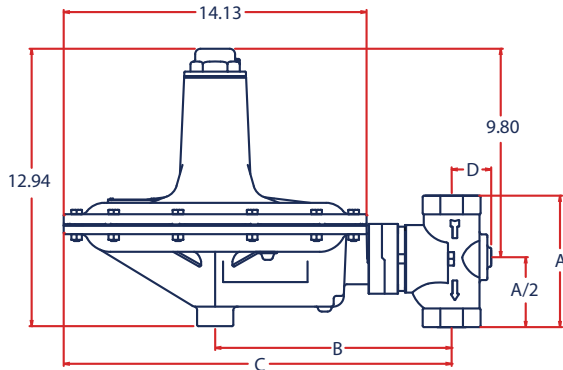

P200 Flanged

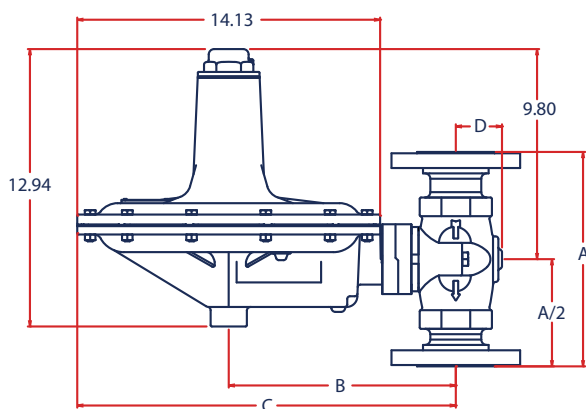

P200 Part Matrix

P200	Version	Configuration	Port Size	Spring Range - WC or PSI / mBAR	Special Construction	Orifice	Port Orientation	Bonnet Orientation	Body Material
1	Non-Relieving						1 Up (Standard)		0 Iron
2	Relieving						2 Down		2 Steel
O		Normal							
H		High							
K		Heavy							
S		Throat Stabilizer							
12			1.25 NPT						
14			1.5 NPT						
15			1.5 x 2 NPT						
16			2 NPT						
004				2 - 4.5" WC 4.98 - 11.20					
006				3.5 - 6.5" WC 8.71 - 16.19					
009				5 - 9" WC 12.45 - 22.41					O, H, K and S Version
014				6 - 14" WC 14.94 - 34.87					
018				8.5 - 18" WC 21.17 - 44.83					
030				14 - 30" WC 34.87 - 74.72					
002				1 - 2 PSIG 68.94 - 137.89					H or S Version Only
003				1.5 - 3.25 PSIG 103.42 - 224.07					
005				2 - 5 PSIG 137.89 - 344.73					
K05				2 - 5.5 PSIG 137.89 - 379.21					K or S version Only
010				4 - 10 PSIG 275.79 - 689.47					
O					None				
A					150 RF (1.5" & 2" Steel Only)				
E					125 FF (2" Iron Only)				
4						1/4"			
6						3/8"			
8						1/2"			
B						3/4"			
D						1"			
F						1-3/16"			
1							Up (Standard)		
2							Down		
3							Right		
4							Left		
C								12 O'Clock	
D								3 O'Clock (Standard)	
E								6 O'Clock	
F								9 O'Clock	
0									Iron
2									Steel

P200 Head Only

P20				0	
	↑	↑	↑	↑	Version
1					Non-Relieving
2					Relieving
					Configuration
0					Normal
H					High
K					Heavy
S					Throat Stabilizer
					Spring Range - WC or PSIG / mBAR
004					2 - 4.5" WC 4.98 - 11.20
006					3.5 - 6.5" WC 8.71 - 16.19
009					5 - 9" WC 12.45 - 22.41
014					6 - 14" WC 14.94 - 34.87
018					8.5 - 18" WC 21.17 - 44.83
030					14 - 30" WC 34.87 - 74.72
002					1 - 2 PSIG 68.94 - 137.89
003					1.5 - 3.25 PSIG 103.42 - 224.07
005					2 - 5 PSIG 137.89 - 344.73
K05					2 - 5.5 PSIG 137.89 - 379.21
010					4 - 10 PSIG 275.79 - 689.47
					H or S Version Only
					K or S version Only
					Special Construction
0					None
					Bonnet Orientation
C					12 O'Clock
D					3 O'Clock (Standard)
E					6 O'Clock
F					9 O'Clock
					Trim Material
0					Nitrile



P200 Body Orientation*

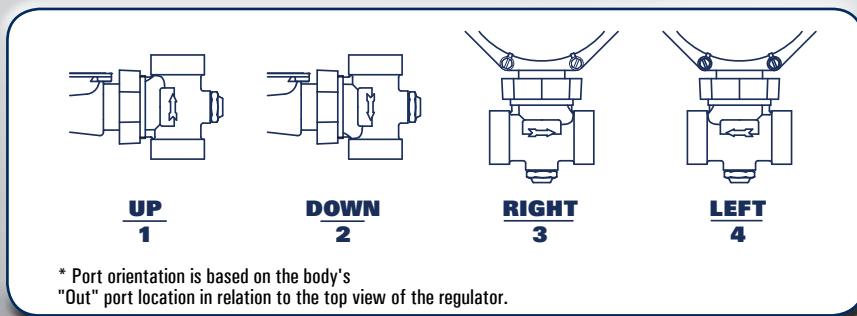

P200 Vent Positions

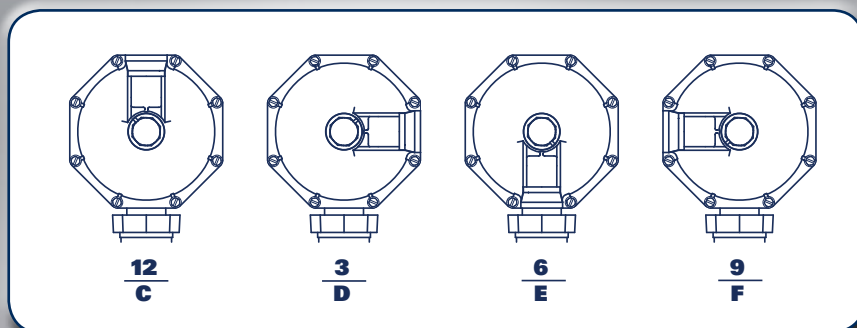

P202 Normal (0) Relief Capacities

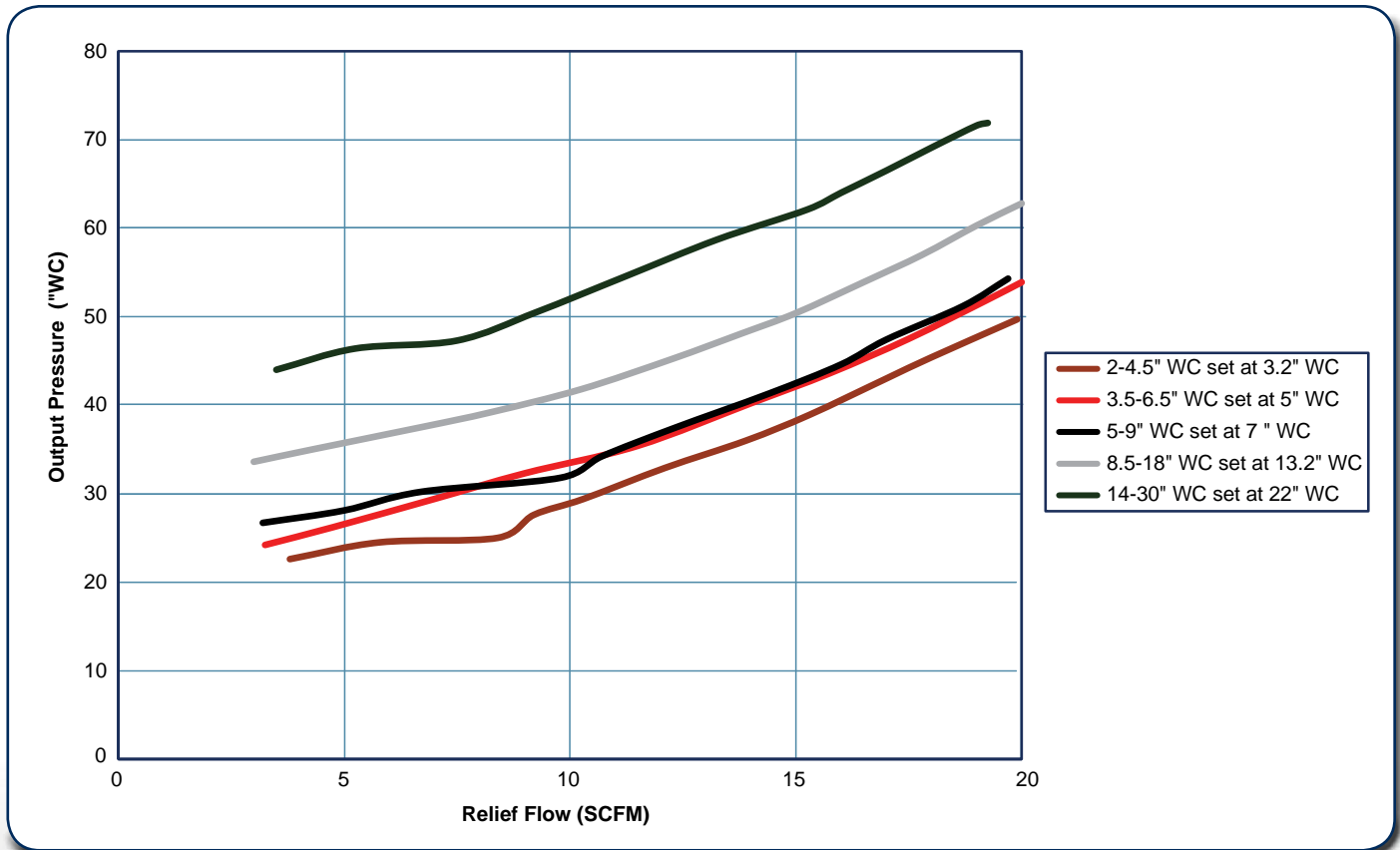

P202 High (H) Relief Capacities

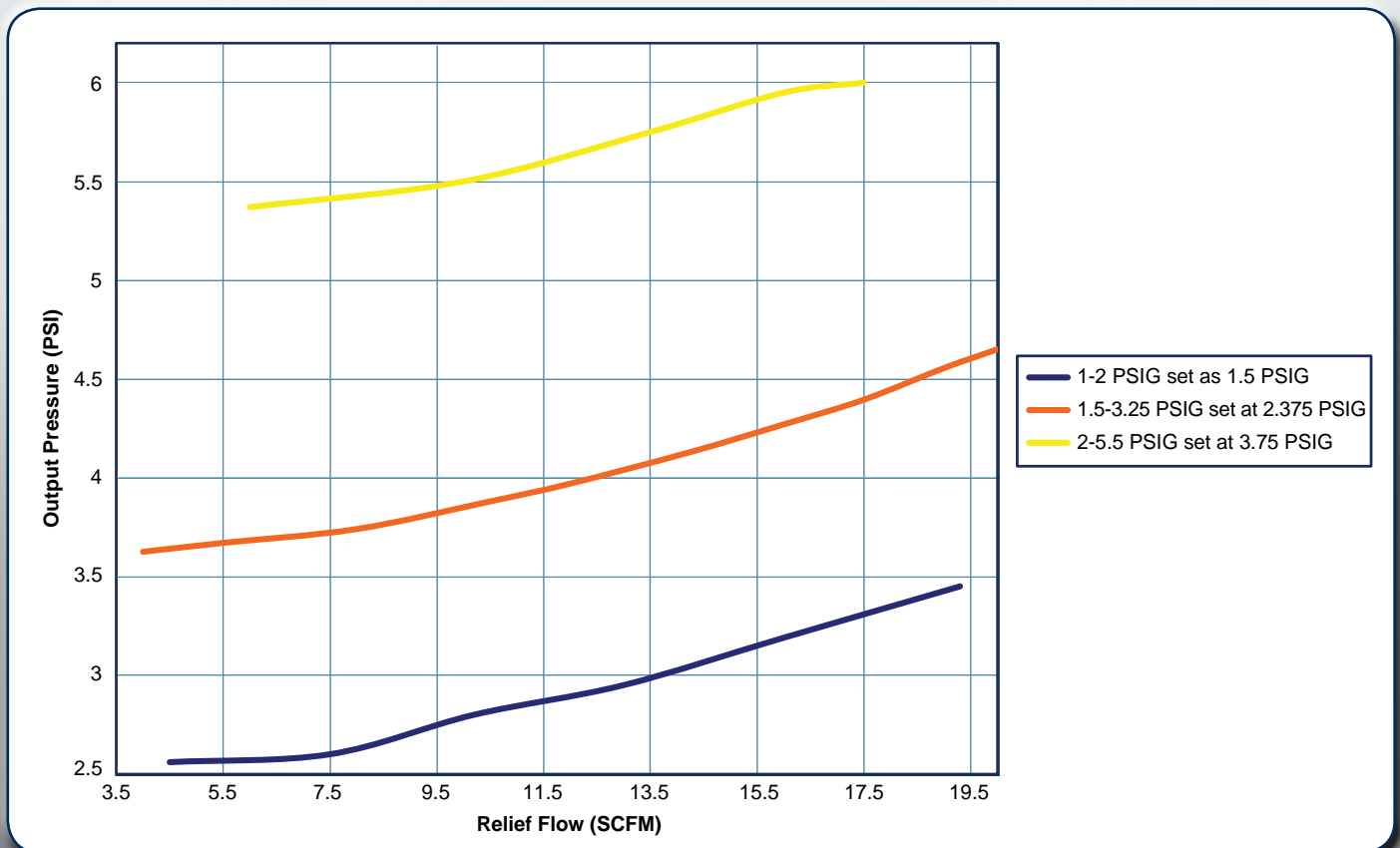

P200 Flow Capacities in SCFH (Nm³/h) of 0.6 Specific Gravity Natural Gas



Outlet Pressure, Spring Part Number, and Accuracy	Inlet Pressure		NPT 1-1/2 Body Size					
			Orifice Size, Inches (mm)					
	PSIG	BAR	1/4 (6.4)	3/8 (9.5)	1/2 (13)	3/4 (19)	1 (25)	1-3/16 (30)
4 inches w.c. (10 mbar) 655-697-002 or 655-697-003 1 inch w.c. (2 mbar) droop 2 inches w.c. (5 mbar) boost	0.4	0.028				1000 (26.8)	1400 (37.5)	1600 (42.8)
	0.5	0.034				1400 (37.5)	1600 (42.8)	1800 (48.2)
	1	0.07	400 (10.7)	800 (21.4)	1200 (32.2)	2100 (56.3)	2500 (67.0)	2700 (72.4)
	1.5	0.10	500 (13.4)	1050 (28.1)	1600 (42.9)	2500 (67.0)	3000 (80.4)	3200 (85.8)
	2	0.14	600 (16.1)	1300 (34.8)	2100 (56.3)	2800 (75.0)	3500 (93.8)	3800 (102)
	5	0.34	1150 (30.8)	2200 (58.9)	3300 (88.4)	4500 (121)	5300 (142)	6000 (161)
	13	0.90	1600 (42.8)	3600 (96.4)	6200 (166)	7000 (188)	6000 (161)	6850 (184)
	25	1.7	2550 (68.3)	5000 (134)	7350 (197)	8950 (240)	9000 (241)	
	60	4.1	4750 (127)	5100 (137)	7050 (189)	5600 (150) ⁽¹⁾		
	100	6.9	6650 (186)	7300 (196)	5200 (139) ⁽¹⁾			
125	8.6	6950 (1)	8300 (222)					
7 inches w.c. (17 mbar) 655-697-004 1 inch w.c. (2 mbar) droop 2 inches w.c. (5 mbar) boost	0.4	0.028				900 (24.1)	1300 (34.8)	1450 (38.9)
	0.5	0.034				1200 (32.2)	1550 (41.5)	1750 (46.9)
	1	0.07	400 (10.7)	800 (21.4)	1100 (29.5)	1900 (50.9)	2300 (61.6)	2500 (67.0)
	1.5	0.10	500 (13.4)	1050 (28.1)	1500 (40.2)	2300 (61.6)	2800 (75.0)	1800 (48.2)
	2	0.14	600 (16.1)	1300 (34.8)	1900 (50.9)	2100 (56.3)	3300 (88.4)	1800 (48.2)
	5	0.34	950 (25.5)	2100 (56.3)	3200 (85.8)	3350 (89.8)	5100 (137)	4500 (121)
	13	0.90	1600 (42.8)	2200 (58.9)	3300 (88.4)	5800 (155)	8000 (214)	8000 (214)
	25	1.7	2200 (58.9)	5200 (139)	6800 (182)	8400 (225)	8750 (235)	
	60	4.1	4300 (115)	9200 (247)	10100 (271)	9900 (265)		
	100	6.9	7500 (201)	10500 (281)	9200 (247) ⁽¹⁾			
125	8.6	9050 (243)	9800 (263) ⁽¹⁾					
11 inches w.c. (27 mbar) 655-697-005 ± 2 inches w.c. (5 mbar)	0.5	0.03				800 (21.4)	1500 (40.2)	1700 (45.6)
	1	0.07	400 (10.7)	700 (18.7)	1100 (29.5)	1800 (48.2)	2200 (58.9)	2450 (65.7)
	1.5	0.10	500 (13.4)	950 (25.5)	1450 (38.9)	2300 (61.6)	2800 (75.0)	2600 (69.7)
	2	0.14	600 (16.1)	1200 (32.2)	1700 (45.6)	1950 (52.3)	3200 (85.8)	2750 (73.7)
	5	0.34	950 (25.5)	2000 (53.6)	2900 (77.7)	3800 (102)	5100 (137)	5150 (138)
	13	0.90	1600 (42.8)	3400 (91.1)	3700 (99.2)	6100 (163)	7250 (194)	7650 (205)
	25	1.7	2100 (56.3)	5150 (138)	7100 (190)	7950 (213)	9400 (252)	
	60	4.1	4400 (118)	9250 (248)	9400 (252)	10400 (279)		
	100	6.9	7300 (196)	10000 (268)	10100 (271)			
	125	8.6	9050 (243)	10800 (289)				
14 inches w.c. (35 mbar) 655-697-005 ± 2 inches w.c. (5 mbar)	1	0.07	450 (12.1)	800 (21.4)	1000 (26.8)	1250 (33.5)	1500 (40.2)	1950 (52.3)
	1.5	0.10	500 (13.4)	850 (22.8)	1050 (28.1)	1550 (41.5)	1650 (44.2)	2350 (62.9)
	2	0.14	550 (14.7)	1150 (30.8)	1400 (37.5)	1750 (46.9)	2300 (61.6)	2500 (67.0)
	5	0.34	1000 (26.8)	1200 (32.2)	2050 (54.9)	3000 (80.4)	4300 (115)	4750 (127)
	13	0.90	1750 (46.9)	3050 (81.7)	4250 (114)	6100 (163)	7300 (196)	7850 (210)
	25	1.7	2500 (67.0)	4750 (127)	5650 (151)	8700 (233)	8700 (233)	
	60	4.1	4750 (127)	9450 (253)	9950 (267)	10550 (283)		
	100	6.9	7450 (200)	10400 (279)	10600 (284)			
	125	8.6	9050 (243)	10450 (280)				
	20 inches w.c. (50 mbar) 655-697-006 ± 3 inches w.c. (7 mbar)	1	0.07	300 (8.04)	500 (13.4)	750 (20.1)	1000 (26.8)	1300 (34.8)
2		0.14	500 (13.4)	950 (25.5)	1400 (37.5)	2000 (53.6)	2800 (75.0)	3100 (83.1)
5		0.34	900 (24.1)	1700 (45.6)	2500 (67.0)	4200 (113)	5000 (134)	5500 (147)
13		0.90	1500 (40.2)	3200 (85.8)	5400 (145)	6500 (174)	7000 (188)	7100 (190)
25		1.7	2100 (56.3)	4700 (126)	7000 (188)	8250 (221)	9350 (251)	
60		4.1	4750 (127)	8900 (239)	9950 (267)	10600 (284)		
100		6.9	7400 (198)	10500 (281)	10800 (289)			
125		8.6	9200 (247)	10950 (293)				

1. Limited due to boost

- Shaded areas show where indicated droop would be exceeded regardless of capacity.
- Shaded areas show where maximum operating inlet pressure for a given port diameter is exceeded.

P200 Flow Capacities in SCFH (Nm³/h) of 0.6 Specific Gravity Natural Gas

Outlet Pressure, Spring Part Number, and Accuracy	Inlet Pressure		NPT 2 (DN 50) Body Size					
			Orifice Size, Inches (mm)					
	PSIG	BAR	1/4 (6.4)	3/8 (9.5)	1/2 (13)	3/4 (19)	1 (25)	1-3/16 (30)
4 inches w.c. (10 mbar) 655-697-002 or 655-697-003 1 inch w.c. (2 mbar) droop 2 inches w.c. (5 mbar) boost	0.4	0.028				1200 (32.3)	1600 (42.8)	1800 (48.2)
	0.5	0.034				1700 (45.6)	2200 (58.9)	2400 (64.3)
	1	0.07	400 (10.7)	900 (24.1)	1300 (34.8)	2800 (75.0)	3200 (85.8)	3800 (102)
	1.5	0.10	500 (13.4)	1100 (29.5)	1700 (45.5)	3600 (96.5)	4300 (115)	5000 (134)
	2	0.14	600 (16.1)	1400 (37.5)	2200 (58.9)	4500 (121)	5500 (147)	6400 (172)
	5	0.34	1000 (26.8)	2300 (61.6)	3700 (99.2)	7800 (209)	9500 (255)	12700 (340)
	13	0.90	1650 (44.2)	3700 (99.2)	6500 (174)	13000 (348)	14000 (375)	14500 (389)
	25	1.7	2500 (64.3)	5200 (139)	9200 (247)	13000 (348)	18000 (482)	
	60	4.1	4450 (119)	9000 (241)	14550 (390)	15000 (402)		
	100	6.9	5500 (147)	9500 (255)	12900 (346) ⁽¹⁾			
125	8.6	7250 (194)	3900 (105) ⁽¹⁾					
7 inches w.c. (17 mbar) 655-697-004 1 inch w.c. (2 mbar) droop 2 inches w.c. (5 mbar) boost	0.4	0.028				950 (25.5)	1400 (37.5)	1600 (42.8)
	0.5	0.034				1500 (40.2)	1800 (48.2)	2000 (53.6)
	1	0.07	400 (10.7)	800 (21.4)	1200 (32.2)	2300 (61.6)	2800 (75.0)	3300 (88.4)
	1.5	0.10	500 (13.4)	1050 (28.1)	1600 (42.8)	3100 (83.1)	3600 (96.5)	4500 (121)
	2	0.14	600 (16.1)	1300 (34.8)	2000 (53.6)	4000 (107)	4500 (121)	6000 (161)
	5	0.34	1000 (26.8)	2100 (56.3)	3500 (93.8)	7700 (206)	9400 (252)	9400 (252)
	13	0.90	1650 (44.2)	3500 (93.8)	6400 (172)	10000 (268)	20200 (541)	21200 (568)
	25	1.7	2400 (64.3)	5200 (139)	10300 (276)	20000 (536)	11800 (316) ⁽¹⁾	
	60	4.1	4450 (119)	9000 (241)	12000 (322)	20700 (555)		
	100	6.9	7500 (201)	10000 (268)	13100 (351)			
125	8.6	9500 (255)	10300 (276)					
11 inches w.c. (17 mbar) 655-697-005 ± 2 inches w.c. (5 mbar)	0.5	0.03				800 (21.4)	1500 (40.2)	1600 (42.8)
	1	0.07	400 (10.7)	750 (20.1)	1100 (29.5)	1800 (48.2)	2500 (64.0)	2600 (69.7)
	1.5	0.10	500 (13.4)	1000 (26.8)	1450 (38.9)	2500 (67.0)	3400 (91.1)	3350 (89.8)
	2	0.14	600 (16.1)	1200 (32.2)	1700 (45.6)	3100 (83.1)	3600 (113)	3750 (101)
	5	0.34	1000 (26.8)	2000 (53.6)	3000 (80.4)	7300 (196)	7000 (188)	8500 (228)
	13	0.90	1600 (42.9)	3400 (91.1)	6200 (166)	10350 (277)	17650 (473)	18100 (485)
	25	1.7	2400 (64.3)	5650 (151)	10350 (277)	19300 (517)	23450 (628)	
	60	4.1	4450 (119)	11350 (304)	19300 (517)	20200 (541)		
	100	6.9	7450 (200)	16650 (446)	20200 (541)			
	125	8.6	9500 (255)	17500 (469)				
14 inches w.c. (35 mbar) 655-697-005 ± 2 inches w.c. (5 mbar)	1	0.07	450 (12.1)	700 (18.8)	1100 (29.5)	1500 (40.2)	1700 (45.6)	2700 (72.4)
	1.5	0.10	550 (14.7)	850 (22.8)	1200 (32.3)	1900 (50.9)	2700 (72.4)	3600 (96.5)
	2	0.14	600 (16.1)	1000 (26.8)	1900 (50.9)	2800 (75.0)	3800 (102)	3800 (102)
	5	0.34	1050 (28.1)	1750 (46.9)	2800 (75.0)	4000 (107)	5300 (142)	10600 (284)
	13	0.90	1750 (46.9)	3700 (99.2)	5700 (153)	14400 (386)	18000 (482)	18500 (496)
	25	1.7	2600 (69.7)	5700 (153)	10200 (273)	18000 (482)	25400 (681)	
	60	4.1	4800 (129)	10900 (292)	11000 (295)	19600 (525)		
	100	6.9	7400 (198)	16500 (442)	14100 (378)			
	125	8.6	9100 (244)	18000 (482)				
20 inches w.c. (50 mbar) 655-697-006 ± 3 inches w.c. (7 mbar)	1	0.07	300 (8.04)	750 (20.1)	550 (14.7)	1250 (33.5)	1700 (45.6)	1800 (48.2)
	2	0.14	500 (13.4)	1150 (30.8)	1700 (45.6)	1900 (50.9)	2350 (62.9)	3250 (87.1)
	5	0.34	900 (24.1)	1650 (44.2)	2150 (57.6)	3250 (87.1)	6400 (172)	6700 (180)
	13	0.90	1500 (40.2)	2550 (68.3)	4350 (117)	5950 (159)	10150 (272)	10500 (281)
	25	1.7	2450 (65.7)	4850 (130)	7200 (193)	18100 (485)	19200 (515)	
	60	4.1	4900 (131)	9400 (252)	19600 (525)	22700 (608)		
	100	6.9	7500 (201)	17400 (466)	13800 (370)			
	125	8.6	9150 (245)	5500 (147) ⁽¹⁾				

1. Limited due to boost

- Shaded areas show where indicated droop would be exceeded regardless of capacity.
- Shaded areas show where maximum operating inlet pressure for a given port diameter is exceeded.

P200 Flow Capacities in SCFH (Nm³/h) of 0.6 Specific Gravity Natural Gas



Outlet Pressure, Spring Part Number, and Accuracy	Inlet Pressure		NPT 1-1/2 Body Size					
			Orifice Size, Inches (mm)					
	PSIG	BAR	1/4 (6.4)	3/8 (9.5)	1/2 (13)	3/4 (19)	1 (25)	1-3/16 (30)
1 PSIG (0.07 BAR) 655-697-006 ± 0.2 PSIG (0.014 BAR)	2	0.14	700 (18.8)	1250 (33.5)	1550 (41.5)	2900 (77.7)	3050 (81.7)	3250 (87.1)
	5	0.34	1050 (28.1)	2150 (57.6)	2800 (75.0)	4800 (129)	5600 (150)	6300 (169)
	10	0.69	1650 (44.2)	3200 (85.8)	4400 (118)	6550 (176)	7800 (209)	8150 (218)
	15	1.0	2000 (53.6)	4100 (110)	5750 (154)	8000 (214)	9400 (252)	10250 (275)
	20	1.4	2300 (61.6)	4750 (127)	6100 (163)	8700 (233)	10950 (293)	
	25	1.7	2600 (69.7)	5500 (147)	8200 (220)	9950 (267)	11550 (310)	
	30	2.1	2900 (77.7)	6250 (168)	8350 (224)	10800 (289)	12250 (328)	
	40	2.8	3600 (96.5)	7500 (201)	9350 (251)	10850 (291)		
	45	3.1	3900 (105)	8400 (225)	10350 (277)	11000 (295)		
	50	3.5	4250 (114)	8900 (239)	10950 (293)	11050 (296)		
	60	4.1	4950 (133)	10000 (268)	11000 (295)	11400 (306)		
	80	5.5	6150 (165)	11150 (299)	11350 (304)			
	100	6.9	7500 (201)	12000 (322)	12000 (322)			
	125	8.6	9150 (245)	12000 (322)				
1 PSIG (0.07 BAR) 655-697-006 ± 1% ABS ± 0.16 psia (0.011 BAR)	2	0.14	650 (17.4)	1050 (28.1)	1350 (36.2)	2450 (65.7)	2700 (72.4)	3000 (80.4)
	5	0.34	1050 (28.1)	2100 (56.3)	2700 (72.4)	3800 (102)	4700 (126)	5200 (139)
	10	0.69	1500 (40.2)	2800 (75.0)	3700 (99.2)	5600 (150)	7000 (188)	7300 (196)
	15	1.0	1950 (52.3)	3750 (101)	4900 (131)	6900 (185)	8500 (228)	8750 (235)
	20	1.4	2200 (58.9)	4600 (123)	5800 (155)	8150 (218)	10350 (277)	
	25	1.7	2500 (67.0)	5000 (134)	7250 (194)	9050 (243)	10850 (291)	
	30	2.1	2800 (75.0)	6000 (161)	8200 (220)	9400 (252)	11000 (295)	
	40	2.8	3550 (95.1)	7350 (197)	9100 (244)	9500 (255)		
	45	3.1	3900 (105)	8250 (221)	9650 (259)	10100 (271)		
	50	3.5	4050 (109)	8450 (226)	10300 (276)	10300 (276)		
	60	4.1	4800 (129)	9050 (243)	10450 (280)	10550 (283)		
	80	5.5	5900 (158)	11000 (295)	11100 (297)			
	10	6.9	7400 (198)	11150 (299)	11500 (299)			
	125	8.6	9000 (241)	11750 (315)				
1 PSIG (0.07 BAR) 655-697-006 ± 2% ABS ± 0.31 psia (0.021 BAR)	2	0.14	750 (20.1)	1450 (38.9)	2100 (56.3)	3700 (99.2)	4650 (125)	5350 (143)
	5	0.34	1250 (33.5)	2500 (67.0)	3550 (95.1)	6050 (162)	7900 (212)	7900 (212)
	10	0.69	1750 (46.9)	3450 (92.5)	5100 (137)	8550 (229)	9550 (256)	10100 (271)
	15	1.0	2050 (54.9)	4350 (117)	6700 (180)	9400 (252)	11250 (302)	11400 (306)
	20	1.4	2500 (67.0)	5150 (138)	8100 (217)	10500 (281)	12200 (327)	
	25	1.7	2700 (72.4)	5800 (155)	10100 (271)	11550 (310)	12600 (338)	
	30	2.1	3050 (81.7)	6650 (178)	10550 (283)	12350 (331)	13100 (351)	
	40	2.8	3700 (99.2)	7950 (212)	10550 (283)	12350 (331)		
	45	3.1	4100 (110)	8800 (236)	11800 (316)	12700 (340)		
	50	3.5	4550 (122)	9250 (248)	12000 (322)	13000 (348)		
	60	4.1	5000 (134)	10900 (292)	12600 (338)	13000 (348)		
	80	5.5	6450 (173)	12550 (336)	13000 (348)			
	10	6.9	7950 (213)	12900 (346)	13450 (360)			
	125	8.6	9450 (253)	13450 (360)				
1 PSIG (0.07 BAR) 655-697-006 ± 0.2 PSIG (0.014 BAR)	2	0.14	500 (13.4)	750 (20.1)	1750 (46.9)	2250 (60.3)	2400 (64.3)	2850 (76.4)
	5	0.34	1100 (29.5)	1800 (48.2)	2300 (61.6)	3400 (91.1)	4850 (130)	5350 (143)
	10	0.69	1600 (42.9)	3200 (85.8)	4600 (123)	7250 (194)	8800 (236)	8800 (236)
	30	2.1	2800 (75.0)	6300 (169)	7800 (209)	10400 (279)	11250 (302)	
	60	4.1	4900 (131)	9600 (257)	9650 (259)	11000 (295)		
	100	6.9	7300 (196)	11200 (300)	11950 (320)			
	125	8.6	9100 (244)	10550 (283) ⁽¹⁾				

1. Limited due to boost

- Shaded areas show where maximum operating inlet pressure for a given port diameter is exceeded.

P200 Flow Capacities in SCFH (Nm³/h) of 0.6 Specific Gravity Natural Gas

Outlet Pressure, Spring Part Number, and Accuracy	Inlet Pressure		NPT 2 (DN 50) Body Size					
			Orifice Size, Inches (mm)					
	PSIG	BAR	1/4 (6.4)	3/8 (9.5)	1/2 (13)	3/4 (19)	1 (25)	1-3/16 (30)
1 PSIG (0.07 BAR) 655-697-006 ±0.2 PSIG (0.014 BAR)	2	0.14	650 (17.4)	1200 (32.2)	2200 (58.9)	3200 (85.8)	3600 (96.5)	4500 (121)
	5	0.34	1100 (25.5)	2300 (61.6)	3200 (85.8)	4800 (129)	7700 (206)	10000 (268)
	10	0.69	1600 (42.9)	3000 (80.4)	4300 (115)	11400 (306)	15200 (407)	16300 (437)
	15	1.0	1900 (50.9)	4000 (107)	6900 (185)	15600 (418)	20800 (557)	22300 (598)
	20	1.4	2300 (61.6)	4900 (131)	9100 (244)	19000 (509)	24000 (643)	
	25	1.7	2600 (69.7)	5600 (150)	10500 (281)	21700 (582)	27400 (734)	
	30	2.1	2900 (77.7)	6500 (174)	11800 (316)	25300 (678)	32800 (879)	
	40	2.8	3700 (99.2)	8000 (214)	14500 (389)	27000 (724)		
	45	3.1	4000 (107)	8800 (236)	15800 (423)	27000 (724)		
	50	3.5	4300 (115)	9300 (249)	16600 (445)	28000 (750)		
	60	4.1	4900 (131)	11300 (303)	19500 (523)	31600 (847)		
	80	5.5	6300 (169)	14200 (381)	24000 (643)			
	100	6.9	7700 (206)	16700 (448)	29500 (791)			
	125	8.6	9600 (257)	20200 (541)				
1 PSIG (0.07 BAR) 655-697-006 ± 1% ABS ±0.16 psia (0.011 BAR)	2	0.14	570 (15.3)	1100 (29.5)	2000 (53.6)	2750 (73.7)	3100 (83.1)	4000 (107)
	5	0.34	1050 (28.1)	2200 (58.9)	2750 (73.7)	4100 (110)	6250 (168)	9000 (241)
	10	0.69	1500 (40.2)	2500 (67.0)	4050 (109)	8500 (228)	13250 (355)	13700 (367)
	15	1.0	1900 (50.9)	3450 (92.5)	5800 (155)	15500 (415)	16000 (429)	16300 (437)
	20	1.4	2300 (61.6)	4800 (129)	7700 (206)	18300 (490)	20850 (559)	
	25	1.7	2500 (67.0)	5600 (150)	10400 (279)	21500 (576)	22800 (611)	
	30	2.1	2900 (77.7)	6350 (170)	11950 (320)	23800 (638)	24300 (651)	
	40	2.8	3650 (97.8)	7850 (210)	14550 (390)	24300 (651)		
	45	3.1	3850 (103)	8400 (225)	15600 (418)	25400 (681)		
	50	3.5	4250 (114)	9350 (251)	16700 (448)	26000 (697)		
	60	4.1	4900 (131)	11200 (300)	19400 (520)	32000 (858)		
	80	5.5	6200 (166)	14250 (382)	24600 (659)			
	100	6.9	7400 (198)	16750 (449)	29000 (777)			
	125	8.6	9350 (251)	20200 (541)				
1 PSIG (0.07 BAR) 655-697-006 ± 2% ABS ±0.31 psia (0.021 BAR)	2	0.14	700 (18.8)	1450 (38.9)	2450 (65.7)	4100 (110)	5600 (150)	7900 (212)
	5	0.34	1150 (30.8)	2550 (68.3)	4000 (107)	8000 (214)	11700 (314)	14300 (383)
	10	0.69	1800 (48.2)	3550 (95.1)	6200 (166)	12300 (330)	18400 (493)	20000 (536)
	15	1.0	2050 (54.9)	4450 (119)	7850 (210)	15900 (426)	22000 (590)	24600 (659)
	20	1.4	2400 (64.3)	5250 (141)	9100 (244)	19200 (515)	25800 (691)	
	25	1.7	2750 (73.7)	5900 (158)	10300 (276)	21800 (584)	31200 (836)	
	30	2.1	3150 (84.4)	6550 (176)	11800 (316)	26200 (702)	35000 (938)	
	40	2.8	3750 (101)	8200 (220)	14300 (383)	30500 (817)		
	45	3.1	4050 (109)	8800 (236)	15600 (418)	28100 (753)		
	50	3.5	4400 (118)	9300 (249)	16700 (448)	33900 (909)		
	60	4.1	5050 (135)	10850 (291)	19500 (523)	34200 (917)		
	80	5.5	6350 (170)	13600 (364)	24600 (659)			
	100	6.9	7850 (210)	17000 (456)	30200 (809)			
	125	8.6	9400 (252)	20500 (549)				
1 PSIG (0.07 BAR) 655-697-006 ±0.2 PSIG (0.014 BAR)	2	0.14	500 (13.4)	1050 (28.1)	1400 (37.5)	2200 (58.9)	2900 (77.7)	3700 (99.2)
	5	0.34	1100 (29.5)	2000 (53.6)	2200 (58.9)	4500 (121)	6600 (177)	7000 (188)
	10	0.69	1600 (42.9)	3500 (93.8)	5700 (153)	9700 (260)	13000 (348)	13300 (356)
	30	2.1	2800 (75.0)	6200 (166)	11700 (314)	20000 (536)	23000 (616)	
	60	4.1	4900 (131)	10900 (292)	19300 (517)	20600 (552)		
	100	6.9	7500 (201)	17300 (464)	23900 (641)			
	125	8.6	9000 (241)	19900 (533)				

1. Limited due to boost

 - Shaded areas show where maximum operating inlet pressure for a given port diameter is exceeded.

P200 H Flow Capacities in SCFH (Nm³/h) of 0.6 Specific Gravity Natural Gas



Outlet Pressure, Spring Part Number, and Accuracy	Inlet Pressure		NPT 1-1/2 Body Size					
			Orifice Size, Inches (mm)					
	PSIG	BAR	1/4 (6.4)	3/8 (9.5)	1/2 (13)	3/4 (19)	1 (25)	1-3/16 (30)
2 PSIG (0.14 BAR) 655-697-007 ±0.2 PSIG (0.014 BAR)	5	0.34	850 (22.8)	1600 (42.9)	1650 (44.2)	2400 (64.3)	2450 (65.7)	3900 (105)
	10	0.69	1450 (38.9)	2050 (54.9)	3250 (87.1)	5400 (145)	5750 (154)	6650 (178)
	15	1.0	1650 (44.2)	3000 (80.4)	4300 (115)	7000 (188)	8200 (220)	8200 (220)
	20	1.4	2050 (54.9)	3850 (103)	5650 (151)	7500 (201)	9050 (243)	
	25	1.7	2500 (67.0)	4600 (123)	6500 (174)	9600 (257)	9700 (260)	
	30	2.1	2750 (73.7)	5650 (151)	6500 (174)	9600 (257)	10850 (291)	
	40	2.8	3500 (93.8)	7000 (188)	8400 (225)	10150 (272)		
	45	3.1	3750 (101)	7800 (209)	9150 (245)	10500 (281)		
	50	3.5	4250 (114)	8500 (228)	9600 (257)	10500 (281)		
	60	4.1	4850 (130)	8800 (236)	9700 (260)	11400 (306)		
	80	5.5	6150 (165)	10000 (268)	11250 (302)			
	100	6.9	7600 (204)	10800 (289)	11250 (302)			
	125	8.6	9300 (249)	12200 (327)				
2 PSIG (0.14 BAR) 655-697-007 ± 1% ABS ± 0.04 psia (0.028 BAR)	5	0.34	1100 (29.5)	2200 (58.9)	2800 (75.0)	4550 (122)	5600 (150)	6550 (176)
	10	0.69	1750 (46.9)	3150 (84.4)	4600 (123)	7550 (202)	9050 (243)	10150 (272)
	15	1.0	2000 (53.6)	4200 (113)	6400 (172)	10050 (269)	11000 (295)	11200 (300)
	20	1.4	2400 (64.3)	5000 (134)	7550 (202)	11700 (314)	12200 (327)	
	25	1.7	2700 (72.4)	5750 (154)	9600 (257)	11900 (319)	12950 (347)	
	30	2.1	3100 (83.1)	6700 (180)	9600 (257)	11900 (319)	13300 (356)	
	40	2.8	3750 (101)	7950 (213)	10750 (288)	13000 (348)		
	45	3.1	4100 (110)	8750 (235)	10750 (288)	13000 (348)		
	50	3.5	4550 (122)	9550 (256)	12700 (340)	13000 (348)		
	60	4.1	5150 (138)	11250 (302)	13300 (356)	14400 (386)		
	80	5.5	6450 (173)	12750 (342)	13300 (356)			
	100	6.9	7750 (208)	14450 (387)	13300 (356)			
	125	8.6	9400 (252)	14600 (391)				
2 PSIG (0.14 BAR) 655-697-007 ± 1% ABS ± 0.17 psia (0.012 BAR)	5	0.34	850 (22.8)	1400 (37.5)	1450 (38.9)	2250 (60.3)	2450 (65.7)	3300 (88.4)
	10	0.69	1400 (37.5)	1650 (44.2)	2550 (68.3)	4350 (117)	5250 (141)	5600 (150)
	15	1.0	1500 (40.2)	2700 (72.4)	3800 (102)	6000 (161)	5400 (145)	8000 (214)
	20	1.4	2000 (53.6)	3600 (96.5)	5200 (139)	7200 (193)	8200 (220)	
	25	1.7	2400 (64.3)	4500 (121)	6400 (172)	9000 (241)	9550 (256)	
	30	2.1	2800 (75.0)	5600 (150)	7500 (201)	10000 (268)	10400 (279)	
	40	2.8	3600 (96.5)	7800 (209)	9200 (247)	10150 (272)		
	45	3.1	3900 (105)	8400 (225)	9800 (263)	10900 (292)		
	50	3.5	4300 (115)	9100 (244)	10300 (276)	10600 (284)		
	60	4.1	5000 (134)	10200 (273)	11400 (306)	11300 (303)		
	80	5.5	6400 (172)	12000 (322)	10300 (276)(1)			
	100	6.9	7900 (212)	13000 (348)	11150 (299)(1)			
	125	8.6	9600 (257)	11950 (320)(1)				
2 PSIG (0.14 BAR) 655-697-007 ± 2% ABS ± 0.33 psia (0.023 BAR)	5	0.34	1050 (28.1)	2100 (56.3)	2500 (67.0)	4100 (110)	5200 (139)	6250 (168)
	10	0.69	1650 (44.2)	3050 (81.7)	4200 (113)	6400 (172)	8350 (224)	8850 (237)
	15	1.0	1900 (50.9)	4200 (113)	6200 (166)	8800 (236)	10500 (281)	10750 (288)
	20	1.4	2200 (58.9)	5100 (137)	7600 (204)	10300 (276)	12000 (322)	
	25	1.7	2500 (67.0)	5800 (155)	8700 (233)	11800 (316)	12050 (323)	
	30	2.1	3000 (80.4)	6500 (174)	9600 (257)	12600 (338)	12700 (340)	
	40	2.8	3600 (96.5)	8100 (217)	11500 (308)	12700 (340)		
	45	3.1	3900 (105)	8800 (236)	12000 (322)	12800 (343)		
	50	3.5	4300 (115)	9700 (260)	12600 (338)	12900 (346)		
	60	4.1	5000 (134)	11300 (303)	13600 (364)	13700 (367)		
	80	5.5	6400 (172)	14200 (381)	12650 (339)			
	100	6.9	7900 (212)	15500 (415)	12950 (347)			
	125	8.6	9600 (257)	14200 (381)(1)				

1. Limited due to boost

- Shaded areas show where maximum operating inlet pressure for a given port diameter is exceeded.

P200 H Flow Capacities in SCFH (Nm³/h) of 0.6 Specific Gravity Natural Gas

Outlet Pressure, Spring Part Number, and Accuracy	Inlet Pressure		NPT 2 (DN 50) Body Size					
			Orifice Size, Inches (mm)					
	PSIG	BAR	1/4 (6.4)	3/8 (9.5)	1/2 (13)	3/4 (19)	1 (25)	1-3/16 (30)
2 PSIG (0.14 BAR) 655-697-007 ±0.2 PSIG (0.014 BAR)	5	0.34	850 (22.8)	1800 (48.2)	1800 (48.2)	2950 (79.1)	4250 (114)	5200 (139)
	10	0.69	1350 (36.2)	1900 (50.9)	3000 (80.4)	5200 (139)	6600 (177)	7800 (209)
	15	1.0	1700 (45.6)	2800 (75.0)	3700 (99.2)	6900 (185)	7200 (193)	9500 (255)
	20	1.4	2000 (53.6)	3800 (102)	5300 (142)	9000 (241)	9800 (263)	
	25	1.7	2450 (65.7)	4500 (121)	6800 (182)	12500 (335)	14200 (381)	
	30	2.1	2650 (71.0)	5200 (139)	7500 (201)	16000 (429)	16100 (431)	
	40	2.8	3400 (91.1)	7400 (198)	13200 (354)	21600 (579)		
	45	3.1	3600 (96.1)	8000 (214)	15500 (415)	21600 (579)		
	50	3.5	4000 (107)	8500 (228)	16700 (448)	21900 (587)		
	60	4.1	4600 (123)	10700 (287)	19200 (515)	18800 (504) ¹⁾		
	80	5.5	5800 (155)	13100 (351)	24800 (665)			
	100	6.9	7100 (190)	16200 (434)	25600 (686)			
	125	8.6	9000 (241)	19900 (533)				
2 PSIG (0.14 BAR) 655-697-007 ±0.4 PSIG (0.028 BAR)	5	0.34	1100 (29.5)	2250 (60.3)	3200 (85.8)	5500 (147)	7800 (209)	10100 (271)
	10	0.69	1600 (42.9)	3250 (87.1)	5400 (145)	10000 (268)	14100 (378)	15100 (405)
	15	1.0	2000 (53.6)	4150 (111)	7200 (193)	14400 (386)	18600 (498)	22100 (592)
	20	1.4	2300 (61.6)	4950 (133)	9000 (241)	17500 (469)	24000 (643)	
	25	1.7	2650 (71.0)	5800 (155)	10200 (273)	20700 (555)	28000 (750)	
	30	2.1	3100 (83.1)	6600 (177)	11800 (316)	24900 (667)	28500 (764)	
	40	2.8	3600 (96.5)	8100 (217)	14600 (391)	28000 (750)		
	45	3.1	4100 (110)	8850 (237)	15800 (423)	29000 (777)		
	50	3.5	4400 (118)	9850 (264)	17200 (461)	29200 (783)		
	60	4.1	4900 (131)	11300 (303)	19500 (523)	29300 (785)		
	80	5.5	6400 (172)	14300 (383)	24500 (657)			
	100	6.9	7600 (204)	17200 (461)	29700 (796)			
	125	8.6	9400 (252)	20500 (549)				
2 PSIG (0.14 BAR) 655-697-007 ± 1% ABS ± 0.17 psia (0.012 BAR)	5	0.34	750 (20.1)	1600 (42.9)	1600 (42.9)	2400 (64.3)	3000 (80.4)	4100 (110)
	10	0.69	1250 (33.5)	1600 (42.9)	2550 (68.3)	4250 (114)	5000 (134)	6100 (163)
	15	1.0	1600 (42.9)	2700 (72.4)	3800 (102)	5200 (139)	6900 (185)	7600 (204)
	20	1.4	2000 (53.6)	3600 (96.5)	5200 (139)	6900 (185)	9400 (252)	
	25	1.7	2450 (65.7)	4400 (118)	7500 (201)	9600 (257)	10650 (285)	
	30	2.1	2800 (75.0)	5200 (139)	8600 (230)	11800 (316)	16100 (431)	
	40	2.8	3700 (99.2)	7500 (201)	12200 (327)	16200 (434)		
	45	3.1	4100 (110)	8400 (225)	15200 (407)	18350 (492)		
	50	3.5	4400 (118)	9000 (241)	16900 (453)	21000 (563)		
	60	4.1	5100 (137)	11000 (295)	20800 (557)	21000 (563)		
	80	5.5	6500 (174)	14600 (391)	24800 (665)			
	100	6.9	8000 (214)	18000 (482)	29300 (785)			
	125	8.6	9800 (263)	20500 (549)				
2 PSIG (0.14 BAR) 655-697-007 ± 2% ABS ± 0.33 psia (0.023 BAR)	5	0.34	1000 (26.8)	2150 (57.6)	2750 (73.7)	5000 (134)	6200 (166)	7900 (212)
	10	0.69	1550 (41.5)	3050 (81.7)	5000 (134)	8600 (230)	12750 (342)	13800 (370)
	15	1.0	1900 (50.9)	4200 (113)	7200 (193)	11000 (295)	11750 (315)	21700 (582)
	20	1.4	2300 (61.6)	5100 (137)	9200 (247)	14200 (381)	16000 (429)	
	25	1.7	2600 (69.7)	5900 (158)	10700 (287)	16400 (440)	25400 (681)	
	30	2.1	3000 (80.4)	6600 (177)	12100 (324)	19700 (528)	27900 (748)	
	40	2.8	3700 (99.2)	8200 (220)	12200 (327)	27200 (729)		
	45	3.1	4100 (110)	9000 (241)	15200 (407)	27200 (729)		
	50	3.5	4400 (118)	9700 (260)	16900 (453)	27400 (734)		
	60	4.1	5100 (137)	11300 (303)	20800 (557)	27400 (734)		
	80	5.5	6500 (174)	14600 (391)	24500 (657)			
	100	6.9	8000 (214)	18000 (482)	29600 (793)			
	125	8.6	9800 (263)	20500 (549)				

1. Limited due to boost

 - Shaded areas show where maximum operating inlet pressure for a given port diameter is exceeded.

P200H Flow Capacities in SCFH (Nm³/h) of 0.6 Specific Gravity Natural Gas



Outlet Pressure, Spring Part Number, and Accuracy	Inlet Pressure		NPT 1-1/2 Body Size					
			Orifice Size, Inches (mm)					
	PSIG	BAR	1/4 (6.4)	3/8 (9.5)	1/2 (13)	3/4 (19)	1 (25)	1-3/16 (30)
3 PSIG (0.21 BAR) 655-697-008 ±0.3 PSIG (0.021 BAR)	5	0.34	800 (21.4)	1350 (36.2)	1650 (44.2)	2500 (67.0)	2500 (67.0)	3850 (103)
	10	0.69	1200 (32.2)	1800 (48.2)	2650 (71.0)	4600 (123)	6050 (162)	6600 (177)
	15	1.0	1650 (44.2)	2300 (61.6)	3750 (101)	5600 (174)	9200 (247)	8200 (220)
	20	1.4	1950 (52.3)	3500 (93.8)	5000 (134)	8350 (224)	9200 (247)	
	25	1.7	2150 (57.6)	4400 (118)	6500 (174)	8150 (218)	10050 (269)	
	30	2.1	2700 (72.4)	5600 (150)	6700 (180)	10050 (269)	11250 (302)	
	40	2.8	3300 (88.4)	6900 (185)	7900 (212)	10300 (275)		
	45	3.1	3550 (95.1)	7000 (188)	8650 (232)	11000 (295)		
	50	3.5	4050 (109)	7800 (209)	9700 (260)	11000 (295)		
	60	4.1	4250 (114)	8200 (220)	9900 (265)	11450 (307)		
	80	5.5	5950 (159)	10000 (268)	11600 (311)			
	100	6.9	7450 (200)	11750 (315)	11900 (319)			
	125	8.6	8800 (236)	12200 (327)				
3 PSIG (0.21 BAR) 655-697-008 ±0.6 PSIG (0.041 BAR)	5	0.34	1100 (29.5)	1950 (52.3)	2800 (75.0)	4250 (114)	5400 (145)	7200 (193)
	10	0.69	1650 (44.2)	3100 (83.1)	4650 (125)	7750 (208)	8700 (233)	9100 (244)
	15	1.0	2050 (54.9)	4100 (110)	5950 (159)	9550 (256)	11150 (299)	11800 (316)
	20	1.4	2400 (64.3)	4900 (131)	7800 (209)	10650 (285)	12350 (331)	
	25	1.7	2600 (69.7)	5750 (154)	8700 (233)	11950 (320)	14050 (377)	
	30	2.1	3100 (83.1)	6550 (176)	10250 (275)	12050 (323)	14400 (386)	
	40	2.8	3150 (84.4)	7850 (210)	11300 (303)	13800 (370)		
	45	3.1	4150 (111)	8400 (225)	12450 (334)	14150 (379)		
	50	3.5	4400 (118)	9300 (249)	12450 (334)	14150 (379)		
	60	4.1	5000 (134)	10700 (287)	13000 (348)	15350 (411)		
	80	5.5	6400 (172)	13050 (350)	16000 (429)			
	100	6.9	7650 (205)	15400 (413)	16050 (430)			
	125	8.6	9200 (247)	16050 (430)				
3 PSIG (0.21 BAR) 655-697-008 ± 1% ABS ± 0.18 psia (0.012 BAR)	5	0.34	500 (13.4)	1150 (30.8)	1200 (32.2)	1450 (38.9)	1550 (41.5)	2100 (56.3)
	10	0.69	900 (24.1)	1350 (36.2)	1500 (40.2)	2750 (73.7)	3200 (85.8)	3400 (91.1)
	15	1.0	1200 (32.2)	1700 (45.6)	2200 (58.9)	3900 (105)	4900 (131)	4950 (133)
	20	1.4	1500 (40.2)	2100 (56.3)	2900 (77.7)	5300 (142)	8000 (214)	
	25	1.7	1900 (50.9)	2600 (69.7)	4300 (115)	7400 (198)	9350 (251)	
	30	2.1	2200 (58.9)	3100 (83.1)	5100 (137)	8400 (225)	8650 (232) ⁽¹⁾	
	40	2.8	2900 (77.7)	4800 (129)	8000 (214)	8750 (235)		
	45	3.1	3300 (88.4)	5800 (155)	9300 (249)	9900 (265)		
	50	3.5	3700 (99.2)	6800 (182)	10200 (273)	10600 (284)		
	60	4.1	4400 (118)	8400 (225)	11600 (311)	10700 (287)		
	80	5.5	6300 (169)	10800 (289)	9400 (252) ⁽¹⁾			
	100	6.9	8100 (217)	12100 (324)	11750 (315)			
	125	8.6	10000 (268)	10750 (288) ⁽¹⁾				
3 PSIG (0.21 BAR) 655-697-008 ± 2% ABS ± 0.35 psia (0.024 BAR)	5	0.34	900 (24.1)	1450 (38.9)	1800 (48.2)	3000 (80.4)	3000 (80.4)	4650 (125)
	10	0.69	1250 (33.5)	2050 (54.9)	3150 (84.4)	5150 (138)	6450 (173)	6650 (178)
	15	1.0	1800 (48.2)	3100 (83.1)	4400 (118)	7200 (193)	8700 (233)	8700 (233)
	20	1.4	2200 (58.9)	3800 (102)	6100 (163)	8600 (230)	11000 (295)	
	25	1.7	2600 (69.7)	5000 (134)	7600 (204)	9700 (260)	11050 (296)	
	30	2.1	2900 (77.7)	5800 (155)	8700 (233)	11200 (300)	11450 (3070)	
	40	2.8	3600 (96.5)	7800 (209)	10800 (289)	11600 (311)		
	45	3.1	4000 (107)	8400 (225)	11600 (311)	11600 (311)		
	50	3.5	4600 (123)	9400 (252)	12400 (332)	11750 (315)		
	60	4.1	5100 (137)	10600 (284)	13800 (370)	13250 (355)		
	80	5.5	6500 (174)	12700 (340)	12600 (338) ⁽¹⁾			
	100	6.9	8100 (217)	14400 (386)	12550 (336) ⁽¹⁾			
	125	8.6	10000 (268)	12500 (335) ⁽¹⁾				

1. Limited due to boost

- Shaded areas show where maximum operating inlet pressure for a given port diameter is exceeded.

P200H Flow Capacities in SCFH (Nm³/h) of 0.6 Specific Gravity Natural Gas

Outlet Pressure, Spring Part Number, and Accuracy	Inlet Pressure		NPT 2 (DN 50) Body Size					
			Orifice Size, Inches (mm)					
	PSIG	BAR	1/4 (6.4)	3/8 (9.5)	1/2 (13)	3/4 (19)	1 (25)	1-3/16 (30)
3 PSIG (0.21 BAR) 655-697-008 ±0.3 PSIG (0.021 BAR)	5	0.34	750 (20.1)	1400 (37.5)	1600 (42.9)	2400 (64.3)	2900 (77.7)	3500 (93.8)
	10	0.69	1200 (32.2)	1900 (50.9)	2750 (73.7)	5000 (134)	6400 (171)	6900 (185)
	15	1.0	1400 (37.5)	2000 (53.6)	3100 (83.1)	5900 (158)	7700 (206)	9800 (263)
	20	1.4	1850 (49.6)	3000 (80.4)	4150 (111)	7700 (206)	7900 (212)	
	25	1.7	2050 (54.9)	3900 (105)	5000 (134)	9100 (244)	9750 (261)	
	30	2.1	2550 (68.3)	4800 (129)	6700 (180)	10100 (271)	17200 (461)	
	40	2.8	3150 (84.4)	6250 (168)	8700 (233)	11600 (311)		
	45	3.1	3400 (91.1)	6750 (181)	9900 (265)	14500 (389)		
	50	3.5	3900 (105)	6750 (181)	12300 (330)	13900 (373)		
	60	4.1	4350 (117)	9400 (252)	12700 (340)	18300 (490)		
	80	5.5	5600 (150)	12700 (340)	18800 (504)			
	100	6.9	7000 (188)	14800 (397)	18800 (504)			
	125	8.6	8650 (232)	18800 (504)				
3 PSIG (0.21 BAR) 655-697-008 ±0.6 PSIG (0.041 BAR)	5	0.34	1100 (29.5)	1950 (52.3)	2550 (68.3)	4700 (126)	6000 (161)	7450 (200)
	10	0.69	1550 (41.5)	3000 (80.4)	4750 (127)	8600 (230)	12200 (327)	15400 (413)
	15	1.0	2050 (54.9)	3850 (103)	5950 (159)	12500 (338)	16200 (434)	20300 (544)
	20	1.4	2400 (64.3)	4850 (130)	8200 (220)	17000 (456)	21800 (584)	
	25	1.7	2800 (75.0)	5750 (154)	9800 (263)	19700 (528)	23000 (616)	
	30	2.1	3150 (84.4)	6450 (173)	11600 (311)	22500 (603)	26500 (710)	
	40	2.8	3650 (97.8)	7850 (210)	14300 (383)	26400 (708)		
	45	3.1	4100 (110)	8900 (239)	15500 (415)	28500 (764)		
	50	3.5	4350 (117)	9450 (253)	17000 (456)	29600 (793)		
	60	4.1	5100 (137)	11100 (297)	19850 (532)	29900 (801)		
	80	5.5	6350 (170)	14350 (385)	25200 (675)			
	100	6.9	7250 (194)	17250 (462)	29400 (788)			
	125	8.6	9400 (252)	21000 (563)				
3 PSIG (0.21 BAR) 655-697-008 ± 1% ABS ± 0.18 psia (0.012 BAR)	5	0.34	650 (17.4)	1100 (29.3)	790 (21.2)	1500 (40.2)	1700 (45.6)	1750 (46.9)
	10	0.69	1000 (26.8)	1250 (33.5)	1500 (40.2)	2500 (67.0)	3700 (99.2)	4300 (115)
	15	1.0	1250 (33.5)	1750 (46.9)	2000 (53.6)	2900 (77.7)	3750 (101)	6000 (161)
	20	1.4	1450 (38.9)	2400 (64.3)	2200 (58.9)	4100 (110)	5750 (154)	
	25	1.7	1600 (42.8)	2900 (77.7)	4000 (107)	6900 (185)	6400 (172)	
	30	2.1	1950 (52.3)	3550 (95.1)	4400 (118)	8700 (233)	6700 (180)	
	40	2.8	2700 (72.4)	3850 (103)	5500 (147)	6450 (173)		
	45	3.1	2900 (77.7)	5400 (145)	9000 (241)	8000 (214)		
	50	3.5	3300 (88.4)	5700 (153)	9100 (244)	7900 (212)		
	60	4.1	3900 (105)	7200 (193)	11500 (308)	10300 (276)		
	80	5.5	5250 (141)	9200 (247)	9800 (263) ⁽¹⁾			
	100	6.9	6250 (168)	11300 (303)	10900 (292) ⁽¹⁾			
	125	8.6	7750 (208)	12650 (339)				
3 PSIG (0.21 BAR) 655-697-008 ± 2% ABS ± 0.35 psia (0.024 BAR)	5	0.34	800 (21.4)	1450 (38.9)	1700 (45.6)	3150 (84.4)	3250 (87.1)	4000 (107)
	10	0.69	1300 (34.8)	2150 (57.6)	3200 (85.8)	5550 (149)	7200 (193)	9000 (241)
	15	1.0	1550 (41.5)	2850 (76.4)	4050 (109)	6800 (182)	8250 (221)	10800 (289)
	20	1.4	1850 (49.6)	3300 (88.4)	5400 (145)	9300 (249)	10900 (292)	
	25	1.7	2350 (62.9)	4650 (125)	6700 (180)	11250 (302)	15600 (418)	
	30	2.1	2450 (65.7)	5100 (137)	8600 (230)	12250 (328)	17350 (465)	
	40	2.8	3150 (84.4)	6950 (186)	11400 (306)	15150 (406)		
	45	3.1	3400 (91.1)	7650 (205)	11900 (319)	18150 (486)		
	50	3.5	3800 (102)	8500 (228)	14000 (375)	20200 (541)		
	60	4.1	4300 (115)	9850 (264)	19000 (509)	21150 (567)		
	80	5.5	5500 (147)	12600 (338)	23100 (619)			
	100	6.9	6500 (174)	15500 (415)	23650 (634)			
	125	8.6	8100 (217)	20650 (553)				

1. Limited due to boost

 - Shaded areas show where maximum operating inlet pressure for a given port diameter is exceeded.

P200H Flow Capacities in SCFH (Nm³/h) of 0.6 Specific Gravity Natural Gas



Outlet Pressure, Spring Part Number, and Accuracy	Inlet Pressure		NPT 1-1/2 Body Size					
			Orifice Size, Inches (mm)					
	PSIG	BAR	1/4 (6.4)	3/8 (9.5)	1/2 (13)	3/4 (19)	1 (25)	1-3/16 (30)
5 PSIG (0.34 BAR) 655-697-009 ±0.5 PSIG (0.034 BAR)	10	0.69	1200 (32.2)	1850 (49.6)	2300 (61.6)	3350 (89.8)	4750 (127)	5500 (147)
	15	1.0	1350 (36.2)	2450 (65.7)	3200 (85.8)	5350 (141)	6650 (178)	7550 (202)
	20	1.4	1850 (49.6)	3200 (85.8)	3900 (105)	6700 (180)	8600 (230)	
	25	1.7	2200 (58.9)	3600 (96.5)	4900 (131)	8250 (221)	10000 (268)	
	30	2.1	2500 (67.0)	5100 (137)	6500 (174)	8800 (236)	11450 (307)	
	40	2.8	3250 (87.1)	6100 (163)	7650 (205)	10650 (285)		
	45	3.1	3650 (97.8)	6950 (186)	8500 (228)	11200 (300)		
	50	3.5	3850 (103)	7550 (202)	9250 (248)	12250 (328)		
	60	4.1	4600 (123)	8550 (229)	10300 (276)	12950 (347)		
	80	5.5	5900 (158)	10550 (283)	12500 (335)			
	100	6.9	7250 (194)	12000 (322)	12550 (336)			
	125	8.6	9000 (241)	13300 (356)				
5 PSIG (0.34 BAR) 655-697-009 ±1 PSIG (0.69 BAR)	10	0.69	1550 (41.5)	2850 (76.4)	4050 (109)	6450 (173)	8450 (226)	9800 (263)
	15	1.0	2000 (53.6)	3850 (103)	5800 (155)	9250 (248)	11150 (299)	12400 (332)
	20	1.4	2450 (65.7)	4750 (127)	7150 (192)	11400 (306)	13250 (355)	
	25	1.7	2800 (75.0)	5700 (153)	8600 (230)	12800 (343)	15250 (409)	
	30	2.1	3100 (83.1)	6400 (172)	10050 (269)	13550 (363)	16800 (450)	
	40	2.8	3700 (99.2)	7850 (210)	12350 (331)	15650 (419)		
	45	3.1	4050 (109)	8600 (230)	13000 (348)	15950 (427)		
	50	3.5	4450 (119)	9400 (252)	13650 (366)	16300 (437)		
	60	4.1	5050 (135)	10700 (287)	15100 (405)	18200 (488)		
	80	5.5	6300 (169)	13400 (359)	17650 (473)			
	100	6.9	7600 (204)	15950 (427)	17650 (473)			
	125	8.6	9200 (247)	17800 (477)				
5 PSIG (0.34 BAR) 655-697-009 ± 1% ABS ± 0.20 psia (0.014 BAR)	10	0.69	650 (17.4)	900 (24.1)	1050 (28.1)	1200 (32.2)	1950 (52.3)	2200 (58.9)
	15	1.0	800 (21.4)	1100 (29.5)	1500 (40.2)	2000 (53.6)	2600 (69.7)	3400 (91.1)
	20	1.4	1050 (28.1)	1400 (37.5)	2050 (54.9)	2800 (75.0)	3800 (102)	
	25	1.7	1200 (32.2)	1800 (48.2)	2350 (62.9)	3800 (102)	4400 (118)	
	30	2.1	1450 (38.9)	2200 (58.9)	3000 (80.4)	4900 (131)	5250 (141)	
	40	2.8	1950 (52.3)	2950 (79.1)	4400 (118)	5750 (154)		
	45	3.1	2200 (58.9)	3300 (88.4)	5000 (134)	6550 (176)		
	50	3.5	2400 (64.3)	3850 (103)	6200 (166)	8200 (220)		
	60	4.1	2950 (79.1)	4800 (129)	8400 (225)	9250 (248)		
	80	5.5	4000 (107)	7400 (198)	7800 (209)			
	100	6.9	5300 (142)	10700 (287)	9200 (247)			
	125	8.6	7200 (193)	6150 (165) ⁽¹⁾				
5 PSIG (0.34 BAR) 655-697-009 ± 2% ABS ± 0.39 psia (0.028 BAR)	10	0.69	1050 (28.1)	1650 (44.2)	1950 (52.3)	2600 (69.7)	3700 (99.2)	4900 (131)
	15	1.0	1350 (36.2)	2050 (54.9)	2900 (77.7)	4300 (115)	5600 (150)	6350 (170)
	20	1.4	1750 (46.9)	2700 (72.4)	3900 (105)	5800 (155)	7400 (198)	
	25	1.7	2100 (56.3)	3350 (89.8)	4850 (130)	7300 (196)	8750 (235)	
	30	2.1	2400 (64.3)	4050 (109)	5750 (154)	8700 (233)	10150 (272)	
	40	2.8	3200 (85.8)	5300 (142)	8000 (214)	9800 (263)		
	45	3.1	3500 (93.8)	6050 (162)	8950 (240)	10750 (288)		
	50	3.5	3900 (105)	6800 (182)	9800 (263)	11000 (295)		
	60	4.1	4700 (126)	8400 (225)	11500 (308)	12100 (324)		
	80	5.5	6150 (165)	11100 (297)	10300 (276) ⁽¹⁾			
	100	6.9	7900 (212)	13100 (351)	11200 (300) ⁽¹⁾			
	125	8.6	9700 (260)	11950 (320) ⁽¹⁾				

1. Limited due to boost

- Shaded areas show where maximum operating inlet pressure for a given port diameter is exceeded.

P200H Flow Capacities in SCFH (Nm³/h) of 0.6 Specific Gravity Natural Gas

Outlet Pressure, Spring Part Number, and Accuracy	Inlet Pressure		NPT 2 (DN 50) Body Size					
			Orifice Size, Inches (mm)					
	PSIG	BAR	1/4 (6.4)	3/8 (9.5)	1/2 (13)	3/4 (19)	1 (25)	1-3/16 (30)
5 PSIG (0.34 BAR) 655-697-009 ±0.5 PSIG (0.034 BAR)	10	0.69	1200 (32.2)	1700 (45.6)	2200 (58.9)	3750 (101)	5300 (142)	5800 (155)
	15	1.0	1400 (37.5)	2100 (56.3)	2850 (76.4)	5500 (147)	6850 (184)	8150 (218)
	20	1.4	1800 (48.2)	2850 (76.4)	3750 (101)	7000 (188)	7700 (206)	
	25	1.7	2050 (54.9)	3750 (101)	4550 (122)	7900 (212)	9750 (261)	
	30	2.1	2500 (67.0)	4550 (122)	5800 (155)	8500 (228)	10750 (288)	
	40	2.8	3150 (84.4)	5800 (155)	6200 (166)	12000 (322)		
	45	3.1	3500 (93.8)	6200 (166)	7000 (188)	12850 (344)		
	50	3.5	3900 (105)	7000 (188)	7700 (206)	14200 (381)		
	60	4.1	4350 (117)	7700 (206)	10950 (293)	16650 (446)		
	80	5.5	5850 (157)	10950 (293)	13500 (362)			
	100	6.9	7150 (192)	13500 (362)	16400 (440)			
	125	8.6	8900 (239)	16400 (440)				
5 PSIG (0.34 BAR) 655-697-009 ±1 PSIG (0.69 BAR)	10	0.69	1500 (40.2)	2800 (75.0)	4050 (109)	7350 (197)	9400 (252)	12400 (332)
	15	1.0	2050 (54.9)	3950 (106)	5700 (153)	10750 (288)	12950 (347)	17100 (458)
	20	1.4	2400 (64.3)	4750 (127)	7300 (196)	13550 (363)	18450 (494)	
	25	1.7	2750 (73.7)	5450 (146)	9100 (244)	16200 (434)	20400 (547)	
	30	2.1	3100 (83.1)	6500 (174)	10500 (281)	19200 (515)	24700 (662)	
	40	2.8	3750 (101)	7850 (210)	13700 (367)	25250 (677)		
	45	3.1	4050 (109)	8550 (229)	15150 (406)	25700 (689)		
	50	3.5	4400 (118)	9600 (257)	16650 (446)	27950 (749)		
	60	4.1	4950 (133)	10850 (291)	19150 (513)	30550 (819)		
	80	5.5	6450 (173)	14000 (375)	24150 (647)			
	100	6.9	7700 (206)	17000 (456)	29400 (788)			
	125	8.6	9250 (248)	20700 (555)				
5 PSIG (0.34 BAR) 655-697-009 ± 1% ABS ± 0.20 psia (0.014 BAR)	10	0.69	500 (13.4)	850 (22.8)	1000 (26.8)	1500 (40.2)	2000 (53.6)	2200 (58.9)
	15	1.0	750 (20.1)	1200 (32.2)	1400 (37.5)	1900 (50.9)	2300 (61.6)	2900 (77.7)
	20	1.4	1000 (26.8)	1550 (41.5)	1900 (50.9)	2700 (72.4)	3000 (80.4)	
	25	1.7	1250 (33.5)	1950 (52.3)	2300 (61.6)	3400 (91.1)	3700 (99.2)	
	30	2.1	1450 (38.9)	2200 (58.9)	2800 (75.0)	4100 (110)	4000 (107)	
	40	2.8	1900 (50.9)	3100 (83.1)	4000 (107)	3300 (88.4)		
	45	3.1	2100 (56.3)	3400 (91.1)	4400 (118)	4600 (123)		
	50	3.5	2400 (64.3)	3800 (102)	5000 (134)	5300 (142)		
	60	4.1	2800 (75.0)	4700 (126)	6600 (177)	7250 (194)		
	80	5.5	3900 (105)	7300 (196)	5050 (135) ⁽¹⁾			
	100	6.9	5000 (134)	9300 (249)	6400 (172) ⁽¹⁾			
	125	8.6	7000 (188)	6000 (161) ⁽¹⁾				
5 PSIG (0.34 BAR) 655-697-009 ± 2% ABS ± 0.39 psia (0.028 BAR)	10	0.69	1000 (26.8)	1400 (37.5)	1650 (44.2)	2900 (77.7)	3500 (93.8)	4500 (121)
	15	1.0	1300 (34.8)	2100 (56.3)	2800 (75.0)	3900 (105)	5500 (147)	5850 (157)
	20	1.4	1650 (44.2)	2750 (73.7)	3600 (96.5)	5300 (142)	7400 (198)	
	25	1.7	2050 (54.9)	3400 (91.1)	4400 (118)	6800 (182)	7400 (196)	
	30	2.1	2400 (64.3)	4000 (107)	5500 (147)	7900 (212)	8350 (224)	
	40	2.8	3100 (83.1)	5400 (145)	7200 (193)	9300 (249)		
	45	3.1	3250 (87.1)	6100 (163)	8300 (222)	9850 (264)		
	50	3.5	3850 (103)	6700 (180)	9400 (252)	10650 (285)		
	60	4.1	4450 (119)	8200 (220)	11500 (308)	14550 (390)		
	80	5.5	6100 (163)	11000 (295)	10850 (291) ⁽¹⁾			
	100	6.9	7600 (204)	14000 (375)	11800 (316)			
	125	8.6	9600 (257)	11650 (312) ⁽¹⁾				

1. Limited due to boost

 - Shaded areas show where maximum operating inlet pressure for a given port diameter is exceeded.

P200 K Flow Capacities in SCFH (Nm³/h) of 0.6 Specific Gravity Natural Gas



Outlet Pressure, Spring Part Number, and Accuracy	Inlet Pressure		NPT 1-1/2 & 2 (DN 50) Body Size					
			Orifice Size, Inches (mm)					
	PSIG	BAR	1/4 (6.4)	3/8 (9.5)	1/2 (13)	3/4 (19)	1 (25)	1-3/16 (30)
5 PSIG (0.34 BAR) 655-659-003 ± 0.5 PSIG (0.034 BAR)	10	0.69	500 (13.4)	1000 (26.8)	1250 (33.5)	1900 (50.9)	2150 (57.6)	2550 (68.3)
	15	1.0	550 (14.7)	1300 (34.8)	1650 (44.2)	2650 (71.0)	3200 (85.8)	4000 (107)
	20	1.4	600 (16.1)	1650 (44.2)	1950 (52.3)	3300 (88.4)	4100 (110)	5000 (134)
	25	1.7	800 (21.4)	1950 (52.3)	2150 (57.6)	3950 (106)	4650 (125)	
	30	2.1	1600 (42.9)	2150 (57.6)	2650 (71.0)	4500 (121)	5500 (147)	
	40	2.8	1950 (52.3)	2650 (71.0)	2900 (77.7)	5800 (155)		
	45	3.1	2250 (60.3)	2900 (77.7)	3450 (92.5)	6200 (166)		
	50	3.5	2450 (65.7)	3450 (92.5)	3800 (102)	6600 (177)		
	60	4.1	2600 (69.7)	3800 (102)	5350 (143)	8700 (233)		
	80	5.5	3700 (99.2)	5350 (143)	5900 (158)			
	100	6.9	4100 (110)	5900 (158)	7950 (213)			
	125	8.6	5450 (146)	7950 (213)				
5 PSIG (0.34 BAR) 655-659-003 ± 1 PSIG (0.69 BAR)	10	0.69	1150 (30.8)	1700 (45.6)	2250 (60.3)	3400 (91.1)	4550 (122)	5650 (151)
	15	1.0	1300 (34.8)	2550 (68.3)	3150 (84.4)	5200 (139)	6350 (170)	8100 (217)
	20	1.4	1900 (50.9)	2950 (79.1)	3950 (106)	6000 (161)	8300 (222)	9950 (267)
	25	1.7	2200 (58.9)	3650 (97.8)	4850 (130)	7050 (189)	9950 (267)	
	30	2.1	2650 (71.0)	4000 (107)	5500 (147)	8750 (235)	11750 (315)	
	40	2.8	3100 (83.1)	5000 (134)	6900 (185)	10850 (291)		
	45	3.1	3450 (92.5)	5800 (155)	7650 (205)	11700 (314)		
	50	3.5	3800 (102)	6450 (173)	8900 (239)	14100 (378)		
	60	4.1	4400 (118)	7450 (200)	9800 (263)	14900 (399)		
	80	5.5	5950 (159)	9300 (249)	12000 (322)			
	100	6.9	7000 (188)	11250 (302)	14750 (395)			
	125	8.6	8450 (226)	13800 (370)				
5 PSIG (0.34 BAR) 655-659-003 ± 1% ABS ± 0.20 psia (0.014 BAR)	10	0.69	350 (9.38)	400 (10.7)	650 (17.4)	800 (21.4)	1050 (28.1)	1300 (34.8)
	15	1.0	350 (9.38)	750 (20.1)	850 (22.8)	1250 (33.5)	1550 (41.5)	1650 (44.2)
	20	1.4	500 (13.4)	900 (24.1)	1050 (28.1)	1650 (44.2)	1800 (48.2)	2050 (54.9)
	25	1.7	600 (16.1)	1000 (26.8)	1200 (32.2)	1650 (44.2)	1950 (52.3)	
	30	2.1	700 (18.8)	1100 (29.5)	1300 (34.8)	1950 (52.3)	2550 (68.3)	
	40	2.8	1000 (26.8)	1350 (36.2)	1350 (36.2)	2450 (65.7)		
	45	3.1	1100 (29.5)	1450 (38.9)	1550 (41.5)	2550 (68.3)		
	50	3.5	1150 (30.8)	1600 (43.9)	1600 (42.9)	3050 (81.7)		
	60	4.1	1150 (30.8)	1750 (46.9)	2250 (60.3)	2400 (64.3) ⁽¹⁾		
	80	5.5	1600 (42.9)	2350 (62.9)	2750 (73.7)			
	100	6.9	1650 (44.2)	2400 (64.3)	3250 (87.1)			
	125	8.6	2150 (57.6)	3050 (81.7)				
5 PSIG (0.34 BAR) 655-659-003 ± 2% ABS ± 0.39 psia (0.028 BAR)	10	0.69	450 (12.1)	450 (12.1)	1100 (29.5)	1500 (40.2)	1700 (45.6)	2250 (60.3)
	15	1.0	450 (12.1)	1150 (30.8)	1500 (40.2)	2150 (57.6)	2500 (67.0)	3300 (88.4)
	20	1.4	550 (14.7)	1400 (37.5)	1700 (45.6)	2800 (75.0)	3350 (89.8)	3900 (105)
	25	1.7	1250 (33.5)	1650 (44.2)	2050 (54.9)	3050 (81.7)	4200 (113)	
	30	2.1	1350 (36.2)	1850 (49.6)	2500 (67.0)	3750 (101)	4350 (117)	
	40	2.8	1700 (45.6)	2200 (58.9)	2900 (77.7)	4700 (126)		
	45	3.1	1800 (48.2)	2350 (62.9)	3500 (93.8)	5200 (139)		
	50	3.5	1900 (50.9)	2850 (76.4)	3950 (103)	5900 (158)		
	60	4.1	2100 (56.3)	2900 (77.7)	4300 (115)	6900 (185)		
	80	5.5	3100 (83.1)	4050 (109)	5500 (147)			
	100	6.9	3400 (91.1)	4800 (129)	6050 (162)			
	125	8.6	4400 (118)	5750 (154)				

1. Limited due to boost

- Shaded areas show where maximum operating inlet pressure for a given port diameter is exceeded.

P200 K Flow Capacities in SCFH (Nm³/h) of 0.6 Specific Gravity Natural Gas

Outlet Pressure, Spring Part Number, and Accuracy	Inlet Pressure		NPT 1-1/2 & 2 (DN 50) Body Size					
			Orifice Size, Inches (mm)					
	PSIG	BAR	1/4 (6.4)	3/8 (9.5)	1/2 (13)	3/4 (19)	1 (25)	1-3/16 (30)
10 PSIG (0.69 BAR) 655-697-010 ± 1 PSIG (0.69 BAR)	10	0.69	550 (14.7)	800 (21.4)	1050 (28.1)	1200 (32.2)	1350 (36.2)	1750 (46.9)
	15	1.0	700 (18.8)	1200 (32.2)	1650 (44.2)	2500 (67.0)	2950 (79.1)	3800 (102)
	20	1.4	800 (21.4)	1650 (44.2)	2100 (56.3)	3150 (84.4)	4450 (119)	5350 (143)
	25	1.7	1500 (40.2)	2000 (53.6)	2750 (73.7)	4350 (117)	4900 (131)	6500 (174)
	30	2.1	1850 (49.6)	2300 (61.6)	3000 (80.4)	4850 (130)	6200 (166)	
	40	2.8	2150 (57.6)	3050 (81.7)	4100 (110)	6400 (172)		
	45	3.1	2300 (61.6)	3400 (91.1)	4600 (123)	7150 (192)		
	50	3.5	2500 (67.0)	3950 (106)	5100 (137)	7650 (205)		
	60	4.1	2900 (77.7)	4350 (117)	6000 (161)	8550 (229)		
	80	5.5	3900 (105)	5950 (159)	7550 (202)			
	100	6.9	4650 (125)	6800 (182)	9650 (259)			
	125	8.6	5300 (142)	8200 (220)				
10 PSIG (0.69 BAR) 655-697-010 ± 2 PSIG (0.14 BAR)	10	0.69	950 (25.5)	1600 (42.9)	2450 (65.7)	3550 (95.1)	3600 (96.5)	4250 (114)
	15	1.0	1550 (41.5)	2350 (62.9)	2900 (77.7)	4900 (131)	6450 (173)	7600 (204)
	20	1.4	1900 (50.9)	3000 (80.4)	4000 (107)	6700 (180)	9000 (241)	10400 (279)
	25	1.7	2300 (61.6)	3800 (102)	5250 (141)	8150 (218)	10300 (276)	13050 (350)
	30	2.1	2750 (73.7)	4750 (127)	6000 (161)	9700 (260)	12200 (327)	
	40	2.8	3400 (91.1)	5850 (157)	7550 (202)	12250 (328)		
	45	3.1	3650 (97.8)	6300 (169)	8800 (236)	13650 (366)		
	50	3.5	3950 (106)	7250 (194)	9300 (249)	15100 (405)		
	60	4.1	4650 (125)	8150 (218)	11000 (295)	16650 (446)		
	80	5.5	5850 (157)	10750 (288)	13750 (369)			
	100	6.9	7250 (194)	12850 (344)	17100 (458)			
	125	8.6	8700 (233)	15750 (422)				
10 PSIG (0.69 BAR) 655-697-010 ± 1% ABS ± 1.5 psia (0.10 BAR)	10	0.69	300 (8.04)	400 (10.7)	350 (9.38)	400 (10.7)	400 (10.7)	450 (12.1)
	15	1.0	350 (9.38)	450 (12.1)	650 (17.4)	750 (20.1)	850 (22.8)	1100 (29.5)
	20	1.4	350 (9.38)	650 (17.4)	700 (18.8)	900 (24.1)	1350 (36.2)	1350 (36.2)
	25	1.7	450 (12.1)	800 (21.4)	950 (25.5)	1200 (32.2)	1500 (40.2)	1900 (50.9)
	30	2.1	700 (18.8)	900 (24.1)	1050 (28.1)	1200 (32.2)	1900 (50.9)	
	40	2.8	700 (18.8)	1100 (29.5)	1150 (30.8)	1850 (49.6)		
	45	3.1	750 (20.1)	1100 (29.5)	1300 (34.8)	2100 (56.3)		
	50	3.5	800 (21.4)	1200 (32.2)	1300 (34.8)	2300 (61.6)		
	60	4.1	850 (22.8)	1300 (34.8)	1450 (38.9)	2300 (61.6)		
	80	5.5	950 (25.5)	1600 (42.9)	1600 (42.9)			
	100	6.9	1050 (28.1)	1950 (52.3)	2600 (69.7)			
	125	8.6	1050 (28.1)	2350 (62.9)				
10 PSIG (0.69 BAR) 655-697-010 ± 2% ABS ± 2.9 psia (0.20 BAR)	10	0.69	400 (10.7)	500 (13.4)	650 (17.4)	900 (24.1)	650 (17.4)	900 (24.1)
	15	1.0	450 (12.1)	550 (14.7)	850 (22.8)	1300 (34.8)	1550 (41.5)	1850 (49.6)
	20	1.4	450 (12.1)	1000 (26.8)	1100 (29.5)	1750 (46.9)	2200 (58.9)	2400 (64.3)
	25	1.7	550 (14.7)	1250 (33.5)	1600 (42.9)	2300 (61.6)	2700 (72.4)	3550 (95.1)
	30	2.1	800 (21.4)	1350 (36.2)	1800 (48.2)	2800 (75.0)	2800 (75.0)	
	40	2.8	1050 (28.1)	1650 (44.2)	2150 (57.6)	3500 (93.8)		
	45	3.1	1350 (36.2)	1900 (50.9)	2600 (69.7)	3700 (99.2)		
	50	3.5	1450 (38.9)	2100 (56.3)	2850 (76.4)	4300 (115)		
	60	4.1	1600 (42.9)	2300 (61.6)	3100 (83.1)	4400 (118)		
	80	5.5	2150 (57.6)	3000 (80.4)	4000 (107)			
	100	6.9	2450 (65.7)	3700 (99.2)	4950 (133)			
	125	8.6	2600 (69.7)	4450 (119)				

1. Limited due to boost

 - Shaded areas show where maximum operating inlet pressure for a given port diameter is exceeded.

P200 O & H

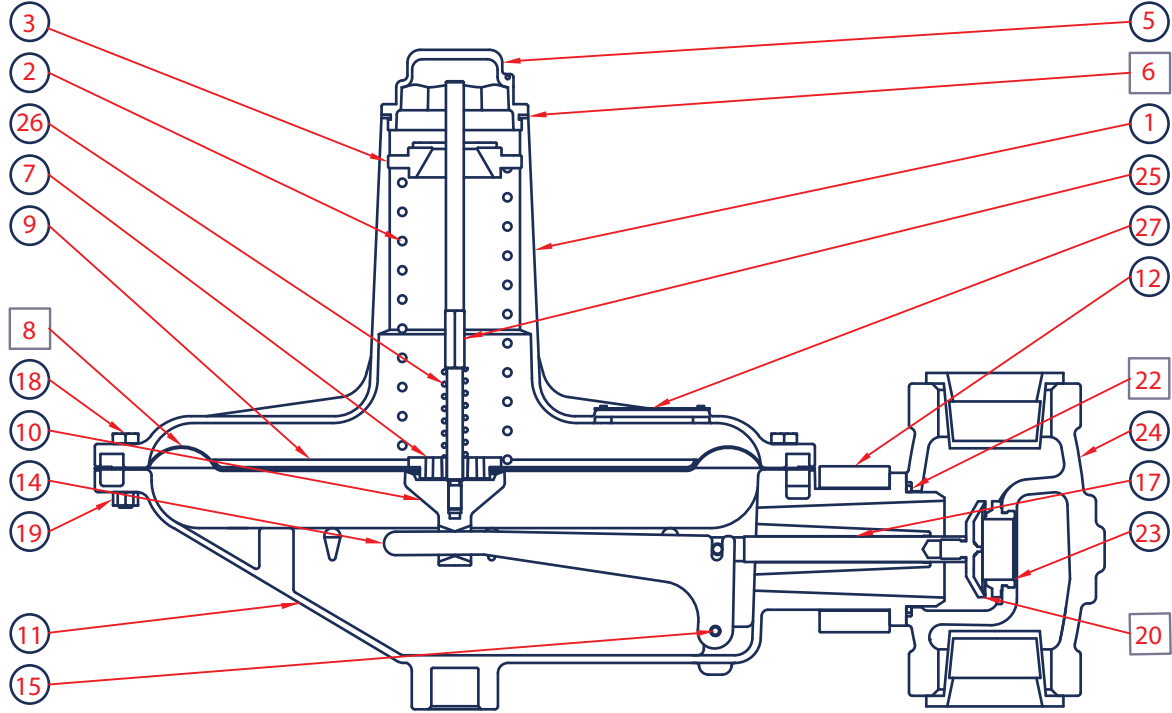

□ Parts included in P200 Low Pressure Repair Kit, 971-200-000

P201 K

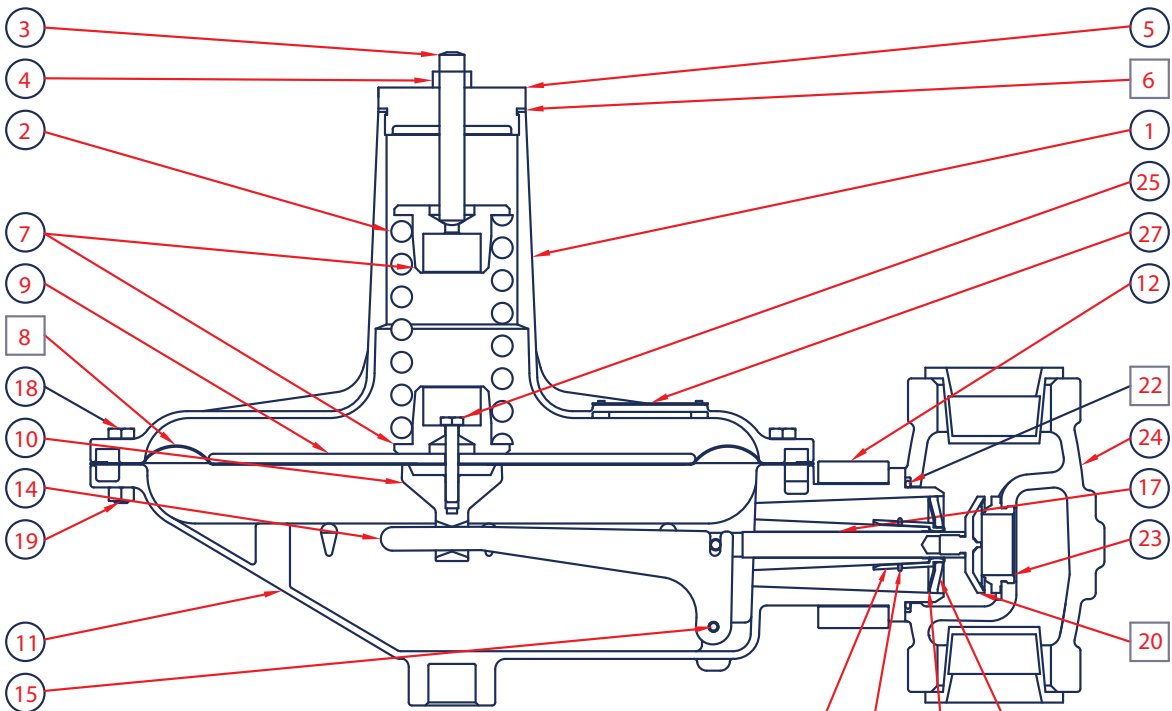

□ Parts included in 971-200-000, T201K Repair Kit

◇ Parts included in 971-200-005, T200 Stabilizer Kit

P200 Parts List

Item	Description	Qty.	Part Number
1	Bonnet (All except H/ 2-5 PSI)	1	604-230-000
	Pinned Spring Case (for 655-697-009 only)		800-132-000
2	Range Spring	1	See Table 2
3	Adjusting Screw	1	648-504-000
	Adjusting Screw (P201K only)		648-462-000
4	Hex Nut (P201K Only)	1	634-000-056
5	Closing Cap	1	610-058-000
	Closing Cap (P201K only)		610-061-000
6	Closing Cap Gasket	1	624-068-000
7	Upper/Lower Spring Seat	1	650-134-000
	Upper/Lower Spring Seat (P201K only)		626-105-000
8	Diaphragm, Nitrile	1	618-072-000
	Diaphragm, (P201K only), Nitrile		618-089-000
9	Diaphragm Head (P201 and P202)	1	628-277-000
	Diaphragm Head (P201H and P202H)		628-279-000
	Diaphragm Head (P201K only)		628-280-000
	Diaphragm Head (P201K only)		628-280-000
10	Pusher Post (P201, P201H, P201K & P201S)	1	637-326-000
	Pusher Post (P202, P202H & P201S)		637-317-000
11	Lower Casing Assembly	1	629-219-000
12	Union Ring	2	644-056-000
13	Spring Pin	1	635-065-000
14	Lever	1	730-000-000
15	Pin	1	635-064-000
16	Machine Screw	2	648-503-000
17	Valve Stem Assembly	1	827-013-000
18	Cap Screw	12	648-506-000
19	Hex Nut	12	634-174-000
20	Disk Holder Assembly, Nitrile	1	822-033-000
21	Cap Screw	2	648-506-001
	O-Ring, Nitrile		649-000-152
23	Orifice, 1/4"	1	688-016-000
	Orifice, 3/8"		688-016-001
	Orifice, 1/2"		688-016-002
	Orifice, 3/4"		688-016-003
	Orifice, 1"		688-016-004
	Orifice, 1-3/16"		688-016-005
24	Iron Body, 2" NPT	1	664-309-000
	Steel Body, 2" NPT		664-342-000
	Iron Body, 1.5" NPT		664-345-000
	Steel Body, 1.5" NPT		664-347-000
	Iron Body, 1.25" NPT		664-345-001
	Steel Body, 1.25" NPT		664-347-001
	Iron Body, 1.5 x 2" NPT		664-349-000
	Steel Body, 1.5 x 2" NPT		664-349-001
	Iron Body, 125 FF 10", 2"		664-377-000
	Steel Body, 150 RF 10", 2"		664-378-000
	Steel Body, 150 RF 10", 1.5"		664-393-000
	Cap Screw (P201 and P201H)		648-506-003
25	Cap Screw (P201K only)	1	648-506-002
	Stem (P202, P202H & P201S)		648-505-000
26	Relief Valve Spring (P202, 202H & P201S)	1	655-697-001
27	Nameplate	1	632-526-000
28	Flapper Stem	1	661-008-000
29	Lower Flapper	1	661-009-000
30	Upper Flapper	1	661-010-000
31	Seat Ring	1	650-136-000
32	Self-Tapping Screw	3	648-502-000
33	Vent Port Spring	2	655-697-000
34	Screen	1	647-018-000
35	Snap Ring	1	693-021-000
66	Stabilizer Gasket (P201S and P202S)	1	624-088-000
67	Stabilizer Frame (P201S and P202S)	1	704-008-000
68	Stabilizer Snap Ring (P201S and P202S)	1	693-028-000
69	Stabilizer Neck (P201S and P202S)	1	608-084-000

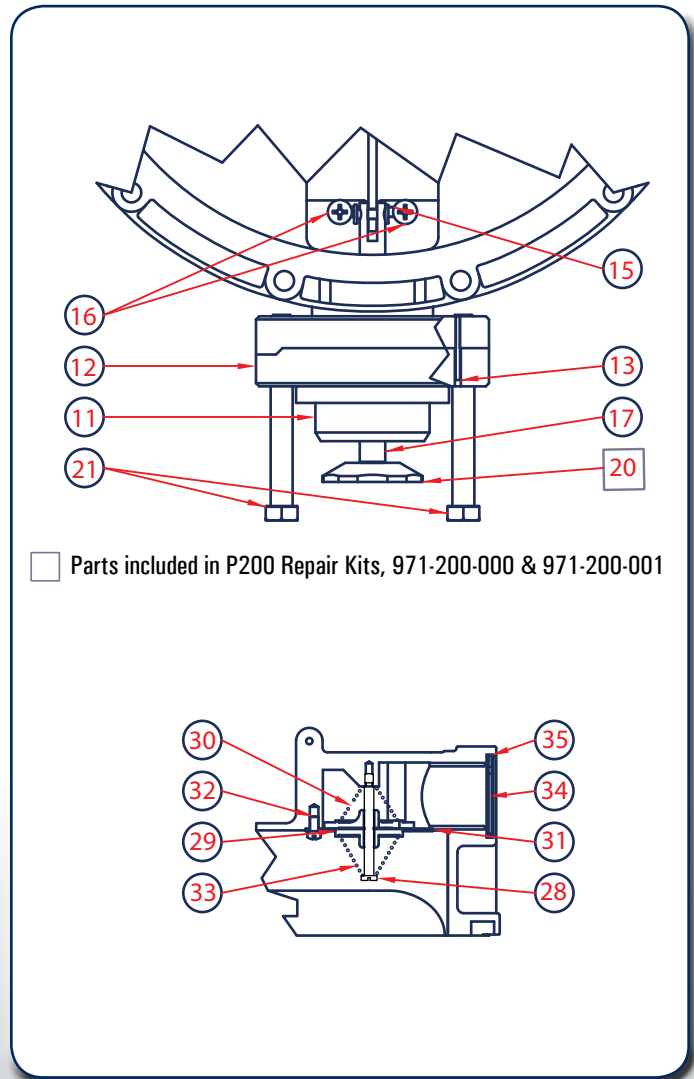

P200P Pressure Regulator

- External Pressure Registration
- Minimize Sudden Downstream Load Change
- Wide Pressure Ranges
- P202 has internal relief valve for overpressure protection

The P200P series pressure regulator is a manual, direct acting, self-operating, spring loaded, adjustable regulator. The P200 series is used in applications where pressure reduction is required. The regulator will reduce the risk of “shock” from abrupt changes of downstream conditions. This can help prevent safety equipment from shutting an operation down.



Applications

- Compressors
- Gas Engines
- Service Regulators

Materials of Construction

Adjusting Screw	Aluminum / Zinc Plated Steel
Body	Ductile Cast Iron or WCB Steel
Bonnet	Aluminum
Closing Cap	Aluminum / Brass
Diaphragm	Nitrile
Lower Casing	Aluminum
Molded Seat Assembly	Nitrile
Orifice	Aluminum
Upper/Lower Spring Seat	Aluminum / Brass
Flange	Ductile Cast Iron / WCB Steel

Specifications

Maximum Inlet	See Table 1	
Maximum Emergency Outlet	15 PSIG	
Pressure Ranges	See Table 2	
Port Sizes	1.25 NPT	
	1.5 NPT	
	1.5 NPT x 2 NPT	
	2 NPT	
Orifice Sizes	1/4"	
	3/8"	
	1/2"	
	3/4"	
	1"	
	1-3/16"	
End Connections	NPT	
	150 RF Flange	Steel Units Only
	125 FF Flange	Iron Units Only
Temperature Range	-20 °F to 180 °F	
	-29 °C to 82 °C	
Approx. Weight	26 lbs. (11.8 kg)	

P200P Series Maximum Inlet Pressure

Orifice Inches	Range	Maximum Inlet Pressure	
		PSIG	BAR
1/4"	Any	125	8.618
3/8"	Any	125	8.618
1/2"	Any	100	6.894
3/4"	Any	60	4.136
1"	2-4.5" thru 14-30" WC	25	1.723
	1-2 thru 4-10 PSIG	30	2.068
1-3/16"	2-4.5" thru 14-30" WC	13	0.896
	1-2 thru 1.5-3.25 PSIG	14	0.965
	2-5 thru 2-5.5 PSIG	20	1.378
	4-10 PSIG	25	1.723

P200 Series Range Springs

Model	Spring Ranges		Spring Color	Part Number
	WC or PSIG	Bar		
	P201P and P202P	2 - 4.5 WC	0.005 - 0.011	Brown
3.5- 6.5 WC		0.009 -0.016	Red	655-697-003
5 - 9 WC		0.012 - 0.022	Black	655-697-004
6 - 14 WC		0.015 - 0.035	Purple	655-697-011
8.5 - 18 WC		0.021 - 0.045	White	655-697-005
14 - 30 WC		0.035 - 0.075	Dark Green	655-697-006
P201P and P202P	1 - 2 PSIG	0.069 - 0.138	Dark Blue	655-697-007
	1.5 - 3.25 PSIG	0.103 - 0.224	Orange	655-697-008
	2 - 5 PSIG	0.138 - 0.345	Yellow	655-697-009
P201P	2 - 5.5 PSIG	0.138 - 0.379	Green	655-659-003
	4 - 10 PSIG	0.276 - 0.689	Grey	655-697-010

P200P Flow Capacities in SCFH (Nm³/h) of 0.6 Specific Gravity Natural Gas



Outlet Pressure, Spring Part Number, and Accuracy	Inlet Pressure		NPT 1-1/2 and 2 / DN 40 and 50 Body Sizes					
			Orifice Size, Inches (mm)					
	PSIG	BAR	1/4 (6.4)	3/8 (9.5)	1/2 (13)	3/4 (19)	1 (25)	1-3/16 (30)
6 inches WC (15 mbar) 655-697-003 ± 1 inch WC (2.5 mbar)	0.4	0.028				1200 (32.2)	1500 (40.2)	1750 (46.9)
	0.5	0.034				1600 (42.9)	1900 (50.9)	2200 (59.0)
	1	0.07	400 (10.7)	900 (24.1)	1300 (34.8)	2300 (61.6)	2900 (77.7)	3300 (88.4)
	1.5	0.10	500 (13.4)	1150 (30.8)	1650 (44.4)	3000 (80.4)	3600 (96.5)	4300 (115)
	2	0.14	600 (16.1)	1400 (37.5)	2000 (53.6)	3500 (93.8)	4200 (113)	5500 (147)
	5	0.34	1000 (26.8)	2300 (61.6)	3500 (93.8)	5700 (153)	7300 (196)	7700 (206)
	13	0.90	1650 (44.2)	3700 (99.2)	6200 (166)	10,000 (268)	13,500 (362)	13,500 (362)
	25	1.7	2400 (64.3)	5200 (139)	9000 (241)	13,500 (362)		
	60	4.1	4400 (118)	9600 (257)	13,500 (362)	13,500 (362)		
	100	6.9	7000 (188)	13,500 (362)	13,500 (362)			
125	8.6	7000 (188)	13,500 (362)					
7 inches WC (17 mbar) 655-697-004 ± 1 inch WC (2.5 mbar)	0.4	0.028				950 (25.5)	1350 (36.2)	1550 (41.5)
	0.5	0.034				1500 (40.2)	1700 (45.6)	1950 (52.3)
	1	0.07	400 (10.7)	800 (21.4)	1200 (32.2)	2000 (53.6)	2600 (69.7)	3000 (80.4)
	1.5	0.10	500 (13.4)	1050 (28.1)	1500 (40.2)	2550 (68.3)	3200 (85.8)	4100 (110)
	2	0.14	600 (16.1)	1300 (34.8)	1800 (48.2)	3000 (80.4)	3700 (99.2)	5000 (134)
	5	0.34	1000 (26.8)	2100 (56.3)	3100 (83.1)	5000 (134)	6500 (174)	7000 (188)
	13	0.90	1650 (44.2)	3300 (88.4)	5500 (147)	8600 (230)	12,000 (322)	13,500 (362)
	25	1.7	2400 (64.3)	5000 (134)	8000 (214)	13,500 (362)	13,500 (362)	
	60	4.1	4400 (118)	9400 (252)	13,500 (362)	13,500 (362)		
	100	6.9	7000 (188)	13,500 (362)	13,500 (362)			
125	8.6	7000 (188)	13,500 (362)					
11 inches WC (27 mbar) 655-697-005 ± 2 inches WC (5 mbar)	0.5	0.03				1450 (38.9)	1650 (44.2)	1850 (49.6)
	1	0.07	375 (10.1)	750 (20.1)	1100 (29.5)	1800 (48.2)	2500 (67.0)	2900 (77.7)
	1.5	0.10	475 (12.7)	1000 (26.8)	1450 (38.9)	2400 (64.3)	3100 (83.1)	3900 (105)
	2	0.14	550 (14.7)	1250 (33.5)	1700 (45.6)	3000 (80.4)	3600 (96.5)	4800 (129)
	5	0.34	950 (25.5)	2000 (53.6)	2900 (77.7)	4800 (129)	6500 (174)	6700 (180)
	13	0.90	1550 (41.5)	3100 (83.1)	5100 (137)	9000 (241)	11,000 (295)	13,500 (362)
	25	1.7	2260 (60.6)	4700 (126)	8000 (214)	13,500 (362)	13,500 (362)	
	60	4.1	4200 (113)	8900 (239)	13,500 (362)	13,500 (362)		
	100	6.9	6600 (177)	13,500 (362)	13,500 (362)			
	125	8.6	6600 (177)	13,500 (362)				
20 inches WC (50 mbar) 655-697-006 ± 3 inches WC (7.5 mbar)	1	0.07	300 (8.04)	500 (13.4)	950 (25.5)	1000 (26.8)	1300 (43.8)	2000 (53.6)
	2	0.14	500 (13.4)	950 (25.5)	1500 (40.2)	2000 (53.6)	2900 (77.7)	4000 (107)
	5	0.34	850 (22.8)	1700 (45.6)	2400 (64.3)	4000 (107)	5000 (134)	5300 (142)
	13	0.90	1350 (36.2)	2800 (75.0)	4400 (118)	6500 (174)	8700 (233)	13,500 (362)
	25	1.7	2000 (53.6)	4800 (129)	6600 (177)	10,000 (268)	13,500 (362)	
	60	4.1	3700 (99.2)	9000 (241)	12,700 (340)	13,500 (362)		
	100	6.9	6000 (161)	13,500 (362)	13,500 (362)			
	125	8.6	6000 (161)	13,500 (362)				
1 PSIG / 0.069 BAR 655-697-007 ± 0.2 PSIG / 0.014 BAR	2.0	0.14	500 (13.4)	750 (20.1)	1100 (29.5)	1400 (37.5)	2400 (64.3)	3000 (80.4)
	6.0	0.41	1100 (29.5)	1800 (48.2)	2500 (67.0)	4000 (107)	5200 (139)	7000 (188)
	14	0.97	1500 (40.2)	3000 (80.4)	4500 (121)	7000 (188)	9000 (241)	13,500 (362)
	30	2.1	2300 (61.6)	4800 (129)	7000 (188)	11,000 (295)	13,500 (362)	
	60	4.1	4400 (118)	9200 (247)	10,500 (281)	13,500 (362)		
	100	6.9	7000 (188)	13,500 (362)	13,500 (362)			
125	8.6	7000 (188)	13,500 (362)					
3 PSIG / 0.21 BAR 655-697-008 ± 0.6 PSIG / 0.041 BAR	3.0	0.21	500 (13.4)	1000 (26.8)	1500 (40.2)	2000 (53.6)	3200 (85.8)	3600 (96.5)
	7.0	0.48	1000 (26.8)	2200 (59.0)	3400 (91.1)	5700 (153)	7000 (188)	8800 (236)
	14	0.97	1500 (40.2)	3000 (80.4)	5700 (153)	10,000 (268)	11,000 (295)	13,000 (362)
	30	2.1	2400 (64.3)	5000 (134)	7500 (201)	13,500 (362)	13,500 (362)	
	60	4.1	4300 (115)	9400 (252)	11,500 (308)	13,500 (362)		
	100	6.9	6800 (182)	11,400 (306)	13,500 (362)			
125	8.6	6800 (182)	11,400 (306)					

1. Limited due to boost

- Shaded areas show where indicated droop would be exceeded regardless of capacity.
- Shaded areas show where maximum operating inlet pressure for a given port diameter is exceeded.

P200P Parts List

Item	Description	Qty.	Part Number
11	Lower Casing	1	629-219-001
17	Valve Stem	1	651-097-001
36	Retaining Ring	1	693-027-000
37	O-ring	1	649-000-005
38	O-ring	1	649-309-004
39	Wiper Ring	1	644-061-000
40	Stem Adaptor	1	653-058-000

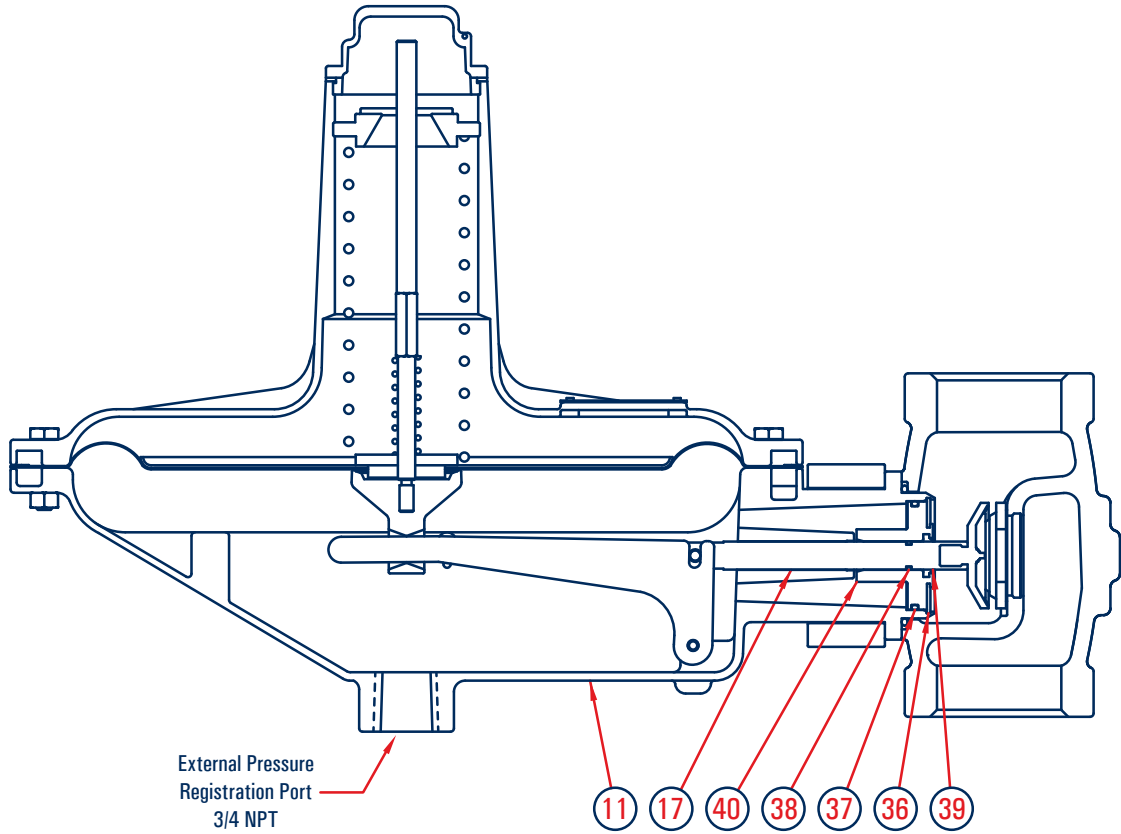

Notes:

P200P Body Orientation*

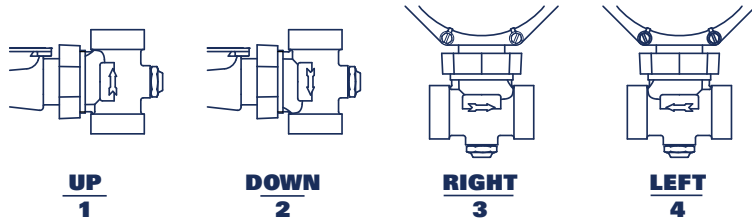

* Port orientation is based on the body's "Out" port location in relation to the top view of the regulator.

P200P Vent Positions

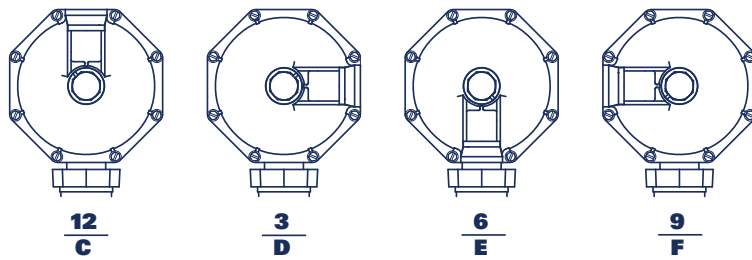



Authorized Distributor:
Linc Energy Systems
www.LincEnergySystems.com



BelGAS, the leader in pressure regulator design, offers the Oil, Gas and Pipeline Industry the same precision and reliability in flow control and pressure control that the control valve market has enjoyed for over 40 years. At BelGAS, we have raised the industry standard for quality, accuracy, and dependability. Even more important is that we provide this value to our customers at an economical price.

The BelGAS product offering includes pressure regulators for gas, air and propane service; explosion-proof I/P transducers for electro-pneumatic applications; process and test gauges for pressure measurement in general and severe service and a wide assortment of bimetal thermometers and thermowells for both high and low temperature indication.

Whether the requirements call for a high pressure flow condition, a low pressure relief application or the regulation of fuel or process gas in a system, BelGAS can provide a dependable and cost effective solution.