

IN-SITU CALIBRATION CHECK FOR SAGE INSERTION THERMAL MASS FLOW METER

Meets U.S. EPA 40 CFR Part 98

3 Easy Steps

STEP 1 LOOSEN Simply *Loosen* the Valve Assembly's Lower Collar Clamp and slightly *Loosen* its Compression Fitting

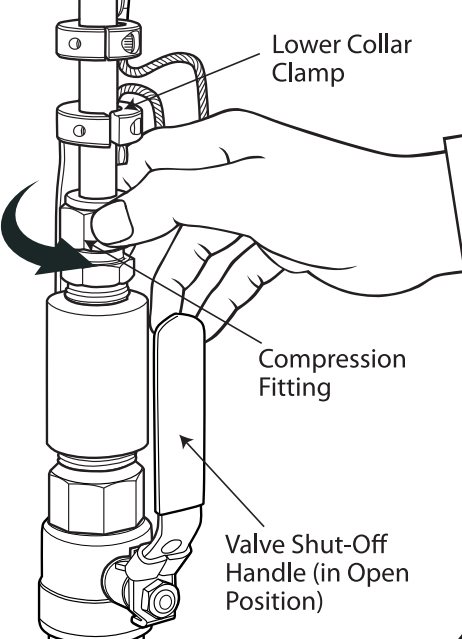

Lower Collar Clamp

Compression Fitting

Valve Shut-Off Handle (in Open Position)

STEP 2 LIFT *Lift* the Probe until Safety Chain is taut, and then *Close* the Valve as shown in the Inset

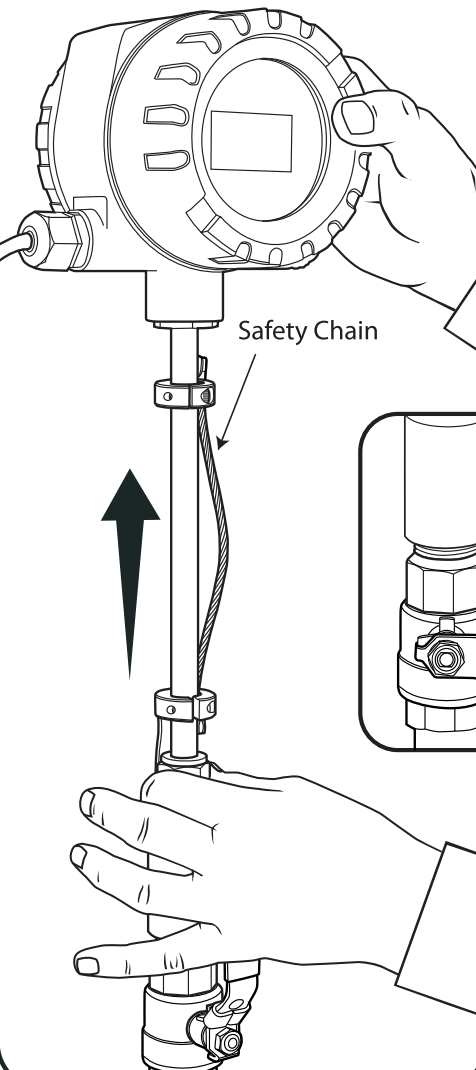

Safety Chain

Close Valve after Lifting

STEP 3 LOOK *Look* at the Milliwatt (mW) Reading on the Display (A), and merely compare it to the Flow Meter's Tag (B)

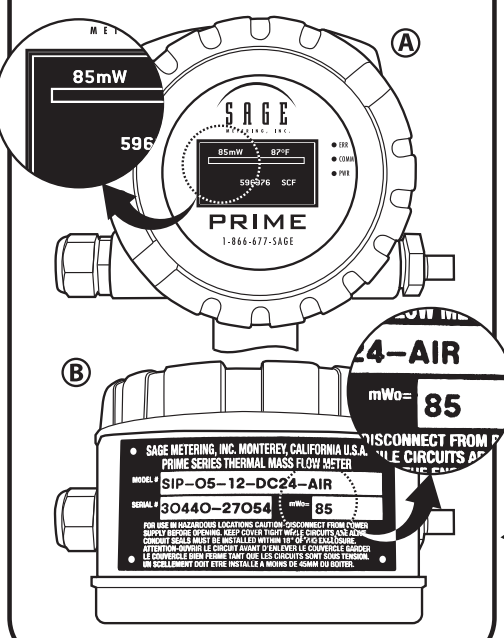

85mW

596

SAGE METERING, INC. MONTEREY, CALIFORNIA U.S.A.
PRIME SERIES THERMAL MASS FLOW METER
MODEL: SIP-05-12-DC24-AIR
SERIAL: 30440-27054
mW= 85

4-AIR

mWo= 85

*The In-Situ Calibration Check, conveniently performed at a "No Flow" (0 SCFM) condition, verifies flow sensor's performance, its cleanliness, and the Flow Meter's operation and calibration. For further details on this procedure, refer to page 46 of the Sage Prime Operations and Instruction Manual.

IN-SITU CALIBRATION CHECK FOR SAGE FLOW METERS – AN EXPLANATION

All Sage Thermal Mass Flow Meters feature the ability for the customer to verify the meter's accuracy, as long as a "No Flow" (0 SCFM) condition can be created.¹ With the Insertion Style Flow Meter, and an SVA05 Isolation Valve Assembly mounting accessory, creating a "No Flow" condition is easy, and takes only a few minutes. See graphic on front page (3-Easy Steps: Loosen, Lift, and Look). More importantly, this simple 3-step procedure can be done In-Situ (i.e., at the site).

The ability to provide a convenient In-Situ calibration check is unique to Sage, and it is a direct result of having developed a digital method of driving the sensors (versus the traditional drift-prone Wheatstone bridge). Since the Sage Flow Meter has extraordinary reproducibility, even at a "No Flow" (0 SCFM) condition, it is an easy matter for the customer to validate that this unique data point hasn't changed since the original NIST Traceable calibration (see *Zeroing Chamber* photo, below). Simply

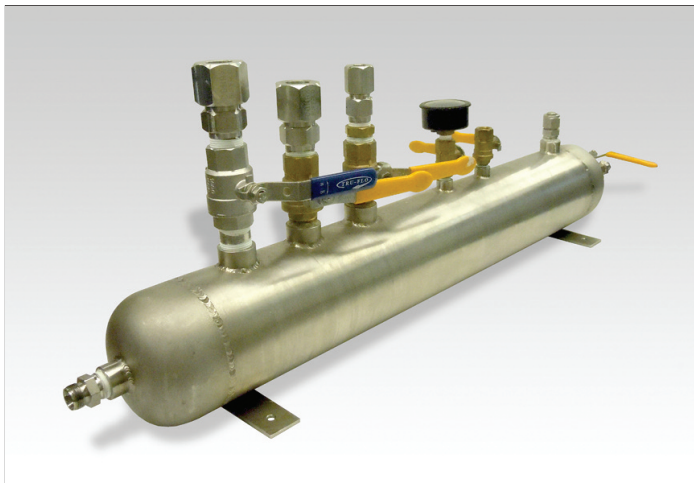

SAGE ZEROING CHAMBER One of the many data points taken during the Flow Meter's NIST calibration at Sage is at a "No Flow" (0 SCFM) condition. The Sage Zeroing Chamber is used to capture a "No Flow" (0 SCFM) flow point at the actual conditions (i.e., with the same gas or gas mix and same pressure as that specified by the customer for their process)

compare the observed milliwatts (mw) to the Factory's original data point (noted on the Flow Meter's Certificate of Conformance or the meter's Tag). In fact, since the Flow Meter's raw calibration data is linearized with a 5th order Polynomial, that is stored digitally, any reproducible data point is sufficient to verify that the original data is intact, but only a "No Flow" (0 SCFM) data point can be truly generated by a customer in the field.

This proprietary technology provides additional benefits as well: Enhanced signal stability; improved temperature compensation; greater sensitivity to flow changes; improved resolution; and even the ability to digitally adjust the dynamic operating range of the meter for the specific process conditions the customer has specified.

The unique Sage In-Situ calibration check assures that the Flow Meter still retains the original NIST Traceable Calibration, and in addition to verifying the meter's accuracy, also confirms that the sensors are clean, and that the Flow Meter hasn't drifted or shifted. This is a tremendous benefit to our customers, since it eliminates the cost and inconvenience of annual calibrations on the flow meters.

Complies with U.S. CFR 40 Part 98 as well as numerous protocols for their calibration verification such as:

U.S. Landfill Protocol, Version 4.0, Par. 6.2

Mexico Landfill Protocol, Version 1.1, Par. 6.2

U.S. Livestock Protocol, Version 3.0, Par. 6.2

U.S. Livestock Protocol, Version 4.0, Par. 6.3

Mexico Livestock Protocol, Version 2.0, Par. 6.2

Please refer to page 46 of the *Sage Prime Operations and Instruction Manual* for further information.

¹ Since all Sage Thermal Mass Flow Meters display or output the raw calibration milliwatts (mw), even In-Line Flow Meters can be checked. To do so, the customer needs to create a "No Flow" (0 SCFM) condition by temporarily shutting down or valving off the Flow to that particular pipe. If that is not possible, consider installing a bypass pipe in parallel with the Flow Meter so that the process flow can bypass the Flow Meter for the few minutes it takes to conduct the Calibration Check at a "No Flow" condition. Alternately, the customer can conduct the check during a routine planned maintenance shutdown. For customers with Insertion Style Flow Meters in low pressure pipes, often compression fittings are utilized rather than isolation valve assemblies. In those cases, the "No Flow" check can still be conducted, but in this case the meter will need to be removed from the pipe and zeroed in some other manner (such as inserting in a small plastic bag or empty water container). In this case, the milliwatt (mw) check will be that of Ambient Air, rather than the Process Gas, which also is listed on the Flow Meter's Certificate of Conformance.



See Sage Metering Product Brochure for additional information and product benefits, or visit us at www.sagemetering.com