



IMAC Systems, Inc.
 90 Main Street, PO Box 1605
 Tullytown, PA 19007

1-800-955-4GAS
 Phone: (215) 946-2200
 Fax: (215) 943-2984

sales@imacsystems.com

INSTALLATION, OPERATION & MAINTENANCE INSTRUCTIONS FOR NGS 1000 NATURAL GAS SCRUBBERS 10 AND 25 SCFM UNITS

NGS 1000

Natural Gas Scrubber

**NEW
 PRODUCT**



Figure 1. NGS 1000
 Natural Gas Scrubber
 Two sizes available NGS-4 and NGS-12

APPLICATION

Designed specifically for industrial applications with natural gas supply lines such as:

- Cata-Dyne™ Series MKII, WX, and BX heaters
- Enclosure systems
- Instrument gas pre-heaters

STANDARD PRODUCT FEATURES

- CRN Certified (#0H6573.213) to 250 psi and 200°F
- Two sizes available
 SIZE 4, 10 SCFM, Ø¼" NPT
 SIZE 12, 25 SCFM, Ø¾" NPT

MOUNTING OPTIONS

With appropriate brackets, the NGS 1000 natural gas scrubber can be installed in an existing piping system or it can be bolted to a wall/panel using the factory supplied stainless steel wall mounting kit.

FEATURES

CRN CERTIFIED #0H6573.213
 Max. Pressure = 250 psi
 Max. Temperature = 200°F
 Min. Temperature = -40°F
 Flow Rates: 10 SCFM to 25 SCFM
 SAE/ORB o-ring design.

BENEFITS

Extend the life of your Cata-Dyne™ infrared heater if sour gas or moisture is present.
 Low-pressure drop at rated flow.

Table 1. Natural Gas Scrubber, Cartridge, and Mounting Kit Coded Numbering System.

Gas Scrubber			Cartridge			Mounting Kit		
NGS	-	4	NGC	-	4	NGS	-	K
↓		↓	↓		↓	↓		↓
Natural Gas Scrubber		4 = 10 SCFM 12 = 25 SCFM	Natural Gas Cartridge		4 = 10 SCFM 12 = 25 SCFM	Natural Gas Scrubber		K = Mounting Kit

INSTALLATION & MAINTENANCE INSTRUCTIONS

WARNINGS

NGS 1000

Natural Gas Scrubbers

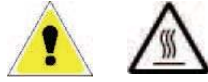

1. Read and follow all instructions contained in this manual before installing, operating, and maintaining this equipment. Failure to do so could void the warranty, damage the equipment, or cause severe injury or death.
2. Relieve all pressure before dismantling unit.

NGC - Cartridges

1. Do not use cartridge if the package has been damaged or seal is broken.
2. Store cartridges at room temperature in a dry/dark place.
3. Avoid contact with eyes or exposed skin.
4. Contents may be harmful if swallowed or inhaled as dust.
5. Spilled or discarded product should be disposed of in accordance with all applicable government regulations.
6. Contents may become hot if exposed to water.

HOW TO ORDER

Natural Gas Scrubber cartridge and mounting kit coded numbering system is presented in Table 1, while the parts list is in Table 2.

INSTRUCTIONS

INSTALLATION PROCEDURE

- A. Read and follow all instructions contained in this manual before installing, operating, and maintaining this equipment. Failure to do so could void the warranty, damage the equipment, or cause severe injury or death.
- B. Review Figure 2 for NGS 1000 scrubber component nomenclature. Refer to Figure 3 for mounting dimensions and NGS scrubber general arrangement. Install scrubber units only in vertical position shown.
- C. Install the NGS 1000 scrubber using appropriate mounting hardware. Optional (factory supplied) universal mounting brackets are available.
- D. **Relieve and block all pressure before installing, maintaining, or dismantling the NGS 1000 scrubber.**
- E. Remove the NGS 1000 scrubber cover (Item 3). Carefully inspect the spring (item 6), the o-ring (item 8), and the cover/housing threads. Remove any dirt, contaminants, or residue from the cover/housing threads prior to final assembly.
- F. Read the label on the NGC Natural Gas Cartridge (Item 1) then remove the cartridge from the factory-sealed bag. **Ensure the contents of the NGC cartridge are never exposed to water.**
- G. Insert the NGC cartridge (Item 1) into the scrubber housing (Item 2). To help with this process you may choose to insert a sheet of rolled paper or transparency into the scrubber housing (Item 2) prior to inserting the NGC cartridge. **Remember to remove the paper or transparency once the NGC cartridge has been installed.**
- H. Re-install the NGS cover (Item 3) using a wrench (see Table 3(b) for hex size) and ensure the cover has completely bottomed out and there is zero gap between the cover and the housing. **CAUTION: DO NOT OVERTIGHTEN the cover or thread damage may occur.** Contact the factory if threads are damaged, corroded, stripped, or galled.
- I. Ensure all fittings are installed and sealed in accordance with the manufacturer's specifications.
- J. Verify that the drain cock (Item 7) is in the fully closed position (clockwise hand tight) before pressurizing the system.

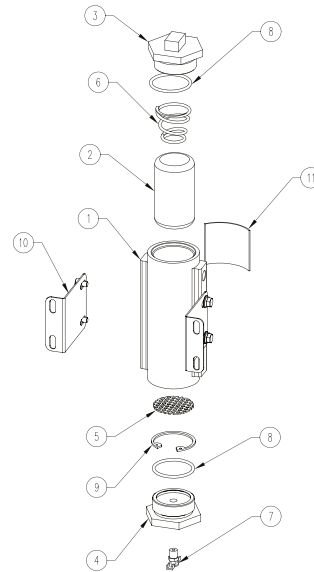

Figure 2. NGS 1000 Gas Scrubber and NGC Cartridge

Table 2. Parts List

ITEM	DESCRIPTION	PART NUMBER	
		NGS-4*	NGS-12*
1	SCRUBBER HOUSING	B16135-01	B16138-01
2	CARTRIDGE	NGC-4	NGC-12
3	THREADED COVER	B16142-01	B16143-01
4	THREADED BASE	B16142-02	B16143-02
5	BAFFLE	A16146-01	A16146-02
6	CONICAL SPRING	A16149-01	
7	DRAIN COCK	A16150-01	
8	ORING	A10069-42	A10069-43
9	SNAP RING	A16154-01	A16154-02
10	MOUNTING BRACKET	NGS-K	
11	LABEL	B16158-01	

* ADD SUFFIX-G FOR Ø1/8" NPT GAUGE PORT OPTION

MAINTENANCE PROCEDURE

- I. Refer to Table 4 to determine the suggested change-out frequency for your Cata-Dyne™ heater application.
- II. **Relieve and block all pressure before installing, maintaining, or dismantling the NGS 1000 scrubber.**
- III. Release and contain any residual water/contaminates from the drain bowl by opening the drain cock (Item 7) counterclockwise.
- IV. Repeat step E of the Installation Instructions.
- V. Remove and properly dispose of used or contaminated cartridges in accordance with all applicable government regulations.
- VI. Repeat steps F through J of the Installation Instructions.

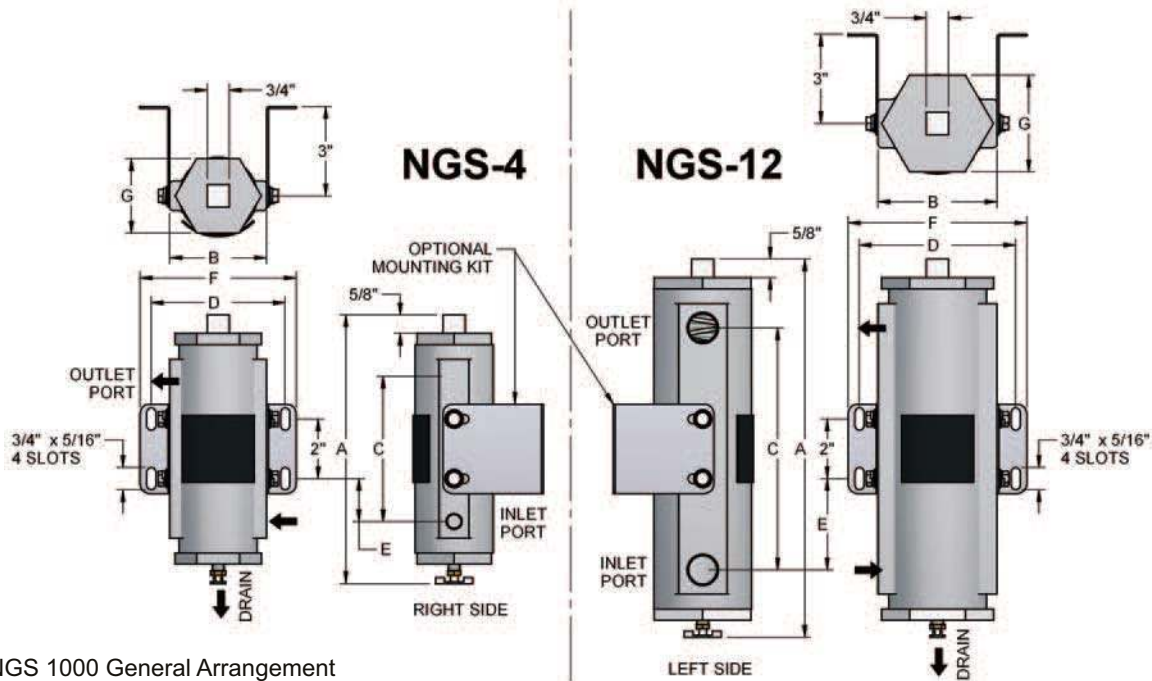

Figure 3. NGS 1000 General Arrangement

Table 3. Dimensions & Information

Model #	Inlet Side	A Overall Length (in.)	B Overall Width (in.)	C Port to Port (in.)	D (in.)	E (in.)	F (in.)	G (in.)	Pipe Size (NPT)	Replacement Cartridge #	Bed Volume (Cu. In.)
NGS-4	Right	9"	3-1/4"	4-7/8"	4-1/2"	1-7/16"	5-1/4"	2-1/2"	Ø1/4"	NGC-4	12.56
NGS-12	Left	12-3/4"	4"	8-1/8"	5-1/4"	3-1/16"	6"	3-1/4"	Ø3/4"	NGC-12	30.78

<div style="border: 1px solid black; padding: 5px;"> <p style="text-align: center;">NATURAL GAS SCRUBBER</p> <p>CCI Thermal Technologies Inc. T: 780-466-3178 F: 780-468-5904 1-800-661-8529 EDMONTON, ALBERTA, CANADA</p> <p style="text-align: center;">WARNING / AVERTISSEMENT RELIEVE ALL PRESSURE BEFORE DISMANTLING UNIT. SOULAGEZ TOUTE LA PRESSION AVANT LE FAIT DE DEMONTER L'UNITE.</p> <p>MODEL NO. / NO. MODELE: SEE TABLE 1</p> <p>MAX. PRESS. / TEMP.: 250 PSI 200 °F</p> <p>S.O. NO. / DATE: W001234 A05</p> <p>CRN NO.: 0H6573.213 B16158-01</p> <div style="text-align: center; margin-top: 10px;"> </div> </div>	<div style="border: 1px solid black; padding: 5px;"> <p style="text-align: center;">NATURAL GAS CARTRIDGE</p> <p>CCI Thermal Technologies Inc. EDMONTON, AB, CANADA 1-800-661-8529 1-780-468-5904</p> <p style="text-align: center;">WARNING</p> <p>DO NOT USE IF PACKAGE IS DAMAGED OR SEAL IS BROKEN. STORE AT ROOM TEMPERATURE IN A DRY/DARK PLACE. CONTENTS MAY BECOME HOT IF EXPOSED TO WATER. AVOID CONTACT WITH EYES OR EXPOSED SKIN. CONTENTS MAY BE HARMFUL IF SWALLOWED OR INHALED AS DUST. SPILLED OR DISCARDED PRODUCT SHOULD BE DISPOSED OF IN ACCORDANCE WITH ALL APPLICABLE GOVERNMENT REGULATIONS.</p> <p>CARTRIDGE NO. NGC-12 BATCH NO. 1234</p> </div>
--	---

Figure 4 (a). Typical Gas Scrubber Nameplate

Figure 4 (b). Typical Gas Cartridge Nameplate

When contacting the factory for service, replacement parts, supplies, or technical information, provide the model number of the scrubber and the cartridge. Typical labels for the scrubbers and cartridges are shown in Figure 4. Also, include the purchase order number, and the date of purchase (if available).

CHANGE-OUT FREQUENCY

Table 4 NGC Cartridge Change Schedule in Days

WX Series Heater	Rating (Btu/hr)	SOUR GAS H ₂ S (10 ppm)		MOISTURE (50 ppm)	
		NGC-4 Days	NGC-12 Days	NGC-4 Days	NGC-12 Days
6 x 6	1,000	696	936	552	752
6 x 12	2,000	348	468	276	376
6 x 24	4,000	174	234	138	188
8 x 8	2,333	298	401	237	322
10 x 12	3,333	209	281	166	226
12 x 12	4,000	174	234	138	188
12 x 24	8,000	87	117	69	94
12 x 36	12,000	58	78	46	63
12 x 48	16,000	44	59	35	47
12 x 60	20,000	35	47	28	38
12 x 72	24,000	29	39	23	31
18 x 24	12,000	58	78	46	63
18 x 36	18,000	39	52	31	42
18 x 48	24,000	29	39	23	31
18 x 60	30,000	23	31	18	25
18 x 72	36,000	19	26	15	21
24 x 24	16,000	44	59	35	47
24 x 30	20,000	35	47	28	38
24 x 36	24,000	29	39	23	31
24 x 48	32,000	22	29	17	24
24 x 60	40,000	17	23	14	19
24 x 72	48,000	15	20	12	19

Table 4 shows cartridge change-out frequencies in days for each model heater and gas scrubber for H₂S and moisture.

To determine the cartridge change-out frequency in days for other H₂S or moisture concentrations, use the formulas provided in the following examples:

Example 1: Sour Gas H₂S

$$\text{Change-out Frequency} = \frac{\# \text{ DAYS (Table 4)}}{10 \text{ ppm}} \times \left[\frac{10 \text{ ppm}}{\text{H}_2\text{S in Gas Supply}} \right]$$

Your installation has a Cata-Dyne™ heater, model WX 12 x 24, 8,000 BTU/hr (2.343 kW/hr) natural gas using a model NGC-4 cartridge.

- The concentration of H₂S in your gas supply is 25 ppm.
- The change-out frequency for 10 ppm is 87 days (derived from Table 4).
- COF = 87 days x 10ppm / 25 ppm = 34.8 days.
- The NGC-4 scrubber cartridge should be changed once every 35 days.

Example 2: Moisture

$$\text{Change-out Frequency} = \frac{\# \text{ DAYS (Table 4)}}{50 \text{ ppm}} \times \left[\frac{50 \text{ ppm}}{\text{Moisture in Gas Supply}} \right]$$

Your installation has a Cata-Dyne™ heater, model WX 12 x 24, 8,000 BTU/hr (2.343 kW/hr) natural gas using a model NGC-4 cartridge.

- The concentration of moisture in your gas supply is 25 ppm.
- The change-out frequency for 50 ppm is 69 days (derived from Table 4).
- COF = 69 days x 50 ppm / 25 ppm = 138 days.
- The NGC-4 scrubber cartridge should be changed once every 138 days.

WARRANTY

CCI Thermal warrants to the purchaser of each new product that any part thereof which proves to be defective in material or workmanship under normal use within 12 months of the date of shipment will be repaired or replaced without charge. Any such defect should be brought to the attention of the company's office from which the product was purchased, which is authorized to furnish repair or replacement within the terms of this warranty.

The company will not be responsible for any expenses incurred in installation, removal from service, transportation cost, or for damages of any type whatsoever, including incidental or consequential damages. Some states or provinces do not allow exclusion or limitation of incidental or consequential damages, so the preceding exclusion or limitation may not be applicable to you.

Since we cannot anticipate or control the conditions under which our products may be used, we accept no responsibility for the safety and suitability of our products when used alone or in combination with other products. Tests for safety and suitability of the products should be done by the user.

This warranty will not apply if, in the judgment of the company, damage or failure has resulted from accident, alteration, misuse, abuse, or operation on an incorrect installation. The foregoing is in lieu of other warranties expressed or implied. CCI Thermal Technologies neither assumes nor authorizes any person to assume for it any other obligation or liability in connection with the said product.

Natural Gas Scrubbers are not guaranteed against damage caused by corrosion.