



DATTUS[®] III

Commercial & Industrial Gas Meter

Building upon its proven lineage, Itron is proud to introduce the third-generation DATTUS, a solid-state gas meter suited for commercial and industrial gas measurement applications. The DATTUS III is built upon an electronics platform that includes a new solid chip thermal sensor, built-in temperature compensation, and datalogging as capabilities—standard.

The DATTUS meter uses fluidic oscillation technology. With no moving parts, the DATTUS meter is ideal for applications where continuous gas flow to the customer is required.

The DATTUS III incorporates a new sensor technology with a solid chip design. The sensor is encapsulated in glass but sensitive enough to detect gas oscillations critical for measurement. The glass coating offers excellent resistance to all types of solid and liquid contaminants.

Meter Type Options

- » **Basic** – Offers uncorrected measurement along with fixed-factor capability
- » **Basic TC** – Same as Basic, but programmed to include temperature compensation

Operational Advantages

- » **Safety** – Because the DATTUS uses solid-state technology, the meter cannot “lock up” or stop gas flow. This may be necessary in some applications such as gas measurement for hospitals, schools, or other applications where continuous gas service may be critical
- » **Robustness** – The DATTUS meter may be subjected to many times its rated capacity without any damage to the meter; only an alarm is displayed letting the user know the meter was in an “overflow” condition. The DATTUS will measure normally once the flow is back within its operating range. With the new and improved solid sensor chip technology, the likelihood of damage from contamination is significantly reduced

- » **Application** – Without mechanical elements impeding gas flow, the meter performs very well in applications where slam-shut or slam-open loads are created because of the downstream equipment used
- » **Ease of Installation** – Having completely aligned flanges is not necessary, nor is leveling of the meter. Neither torsion on the meter case or a non-level setting will affect meter performance
- » **Low Maintenance** – Since the DATTUS meter doesn't have any rotating or moving parts, there are no associated maintenance requirements, such as oil changes that may be required for other meter types. Batteries are the only regular maintenance item for DATTUS, with battery life expectancy at nine to ten years for the DATTUS Basic and Basic TC models



DATTUS III fM1



DATTUS III fM2



DATTUS III fM3

FEATURES AND BENEFITS

- » Static measurement technology
- » Built-in temperature compensation
- » Data logging standard
- » Four channels of configurable pulse outputs
- » Capacity sizes from 8C to 56M
- » Field upgradable meter capacity without service interruption
- » 9-10 year battery life
- » Configurable index orientation
- » MODBUS communication
- » Programmable fixed pressure compensation
- » Highly robust sensor design

Pulse Outputs

- » 4 pulse output channels
- » Open drain N channel MOSFET, non-isolated
- » Dry contact
- » Switch off resistance > 2 Mohms
- » Switch on resistance ~ 250 ohms
- » Pulse duration: 10ms to 2 seconds or 50% duty cycle
- » Pulse value: user configurable for volume pulse or alarm output

Data Logging

- » Data logging is standard
- » Four individually configurable loggers
- » Intervals from 30 seconds up to monthly
- » Four items may be logged in addition to uncorrected volume, including temperature, corrected volume, maximum flow rate, and battery voltages
- » Total of 2730 records available

Event logging

- » Records and time stamps meter alarms
- » Records and time stamps configuration changes
- » Uses a circular log
- » Additional "last occurrence" log

Temperature Compensation

- » Temperature sensing chip included on the sensor board and mounted in the gas stream
- » May enable or disable temperature compensation via software
- » Accuracy of +/- 1.8 degrees Fahrenheit

Specifications

Model	fM1 CFH (m3/h)	fM2 CFH (m3/h)	fM3 CFH (m3/h)
Start Flow	8 (0.23)	18 (0.51)	45 (1.27)
Flow rate for +/- 2% acc.	10 (0.28)	22 (0.62)	60 (1.70)
Flow rate for +/- 1% acc.	35 (0.99)	60 (1.70)	100 (2.83)
Maximum Capacity	3750 (106)	13750 (389)	57000 (1614)

Meter	Meter Weight	Shipped Weight	MAOP	Operating Temperature Range	Approvals for Intrinsic Safety
fM1	34 lbs. (15.4 kg)	38 lbs. (17.2 kg)	175 PSIG, 12 Bar	-40° to +140° F, -40° to + 60° C	UL 913 Class I Div I, CSA 22.2 No. 157
fM2	37 lbs. (16.8 kg)	42 lbs. (19.1 kg)	150 PSIG, 10.3 Bar		
fM3	114 lbs. (51.7 kg)	128 lbs. (58.1 kg)	175 PSIG, 12 Bar		

Meter Sizing – fM1

Meter Size Base Rating	8C acfh (m ³ /h)	1M acfh (m ³ /h)	1.5M acfh (m ³ /h)	2M acfh (m ³ /h)	3M acfh (m ³ /h)
	800 (22.7)	1000 (28.3)	1500 (42.5)	2000 (56.6)	3000 (85.0)

Meter Pressure psig (Bar)	Metering Capacity				
	MSCFH(m ³ /h)	MSCFH(m ³ /h)	MSCFH(m ³ /h)	MSCFH(m ³ /h)	MSCFH(m ³ /h)
1 (0.07)	0.9 (24.2)	1.1 (30.2)	1.6 (45.4)	2.1 (60.5)	3.2 (90.7)
2 (0.14)	0.9 (25.7)	1.1 (32.2)	1.7 (48.2)	2.3 (64.3)	3.4 (96.5)
3 (0.21)	1.0 (27.3)	1.2 (34.1)	1.8 (51.1)	2.4 (68.2)	3.6 (102.3)
5 (0.34)	1.1 (30.3)	1.3 (37.9)	2.0 (56.9)	2.7 (75.9)	4.0 (113.8)
10 (0.69)	1.3 (38.0)	1.7 (47.5)	2.5 (71.3)	3.4 (95.1)	5.0 (142.6)
15 (1.03)	1.6 (45.7)	2.0 (57.2)	3.0 (85.7)	4.0 (114.3)	6.1 (171.5)
20 (1.38)	1.9 (53.4)	2.4 (66.8)	3.5 (100.1)	4.7 (133.5)	7.1 (200.3)
25 (1.72)	2.2 (61.1)	2.7 (76.4)	4.0 (114.6)	5.4 (152.8)	8.1 (229.1)
45 (3.10)	3.2 (91.9)	4.1 (114.8)	6.1 (172.2)	8.1 (229.7)	12.2 (344.5)
60 (4.13)	4.1 (114.9)	5.1 (143.7)	7.6 (215.5)	10.1 (287.3)	15.2 (431.0)
90 (6.20)	5.7 (161.1)	7.1 (201.3)	10.7 (302.0)	14.2 (402.7)	21.3 (604.0)
100 (6.89)	6.2 (176.4)	7.8 (220.6)	11.7 (330.8)	15.6 (441.1)	23.4 (661.7)
150 (10.3)	8.9 (253.3)	11.2 (316.7)	16.8 (475.0)	22.4 (633.4)	33.5 (950.0)
175 (12.1)	10.3 (291.8)	12.9 (364.7)	19.3 (547.1)	25.8 (729.5)	38.6 (1094.2)

Meter Sizing – fM2

Meter Size Base Rating	2M acfh (m ³ /h)	3M acfh (m ³ /h)	5M acfh (m ³ /h)	7M acfh (m ³ /h)	11M acfh (m ³ /h)
	2000 (56.6)	3000 (85.0)	5000 (141.6)	7000 (198.2)	11000 (311.5)

Meter Pressure psig (Bar)	Metering Capacity				
	MSCFH(m ³ /h)	MSCFH(m ³ /h)	MSCFH(m ³ /h)	MSCFH(m ³ /h)	MSCFH(m ³ /h)
1 (0.07)	2.1 (60.5)	3.2 (90.7)	5.3 (151.2)	7.5 (211.7)	11.7 (332.6)
2 (0.14)	2.3 (64.3)	3.4 (96.5)	5.7 (160.8)	8.0 (225.1)	12.5 (353.8)
3 (0.21)	2.4 (68.2)	3.6 (102.3)	6.0 (170.4)	8.4 (238.6)	13.2 (374.9)
5 (0.34)	2.7 (75.9)	4.0 (113.8)	6.7 (189.6)	9.4 (265.5)	14.7 (417.2)
10 (0.69)	3.4 (95.1)	5.0 (142.6)	8.4 (237.7)	11.8 (332.8)	18.5 (523.0)
15 (1.03)	4.0 (114.3)	6.1 (171.5)	10.1 (285.8)	14.1 (400.1)	22.2 (628.7)
20 (1.38)	4.7 (133.5)	7.1 (200.3)	11.8 (333.8)	16.5 (467.4)	25.9 (734.4)
25 (1.72)	5.4 (152.8)	8.1 (229.1)	13.5 (381.9)	18.9 (534.6)	29.7 (840.2)
45 (3.10)	8.1 (229.7)	12.2 (344.5)	20.3 (574.1)	28.4 (803.8)	44.6 (1263.1)
60 (4.13)	10.1 (287.3)	15.2 (431.0)	25.4 (718.3)	35.5 (1005.6)	55.8 (1580.3)
90 (6.20)	14.2 (402.7)	21.3 (604.0)	35.5 (1006.7)	49.8 (1409.4)	78.2 (2214.7)
100 (6.89)	15.6 (441.1)	23.4 (661.7)	38.9 (1102.8)	54.5 (1543.9)	85.7 (2426.2)
150 (10.3)	22.4 (633.4)	33.5 (950.0)	55.9 (1583.4)	78.3 (2216.8)	123.0 (3483.5)

Dimensions

	fM1 in (mm)	fM2 in (mm)	fM3 in (mm)
A	17.2 (437)	18.6 (472)	25.2 (640)
B	8.8 (224)	10.6 (269)	16.5 (419)
C	6.75 (171)	6.75 (171)	9.5 (241)
D	11.25 (286)	12.1 (307)	16.7 (424)
E	7.6 (193)	7.6 (193)	7.6 (193)
Flange:	ANSI 125 2"	ANSI 125 2" or 3"	ANSI 125 4"

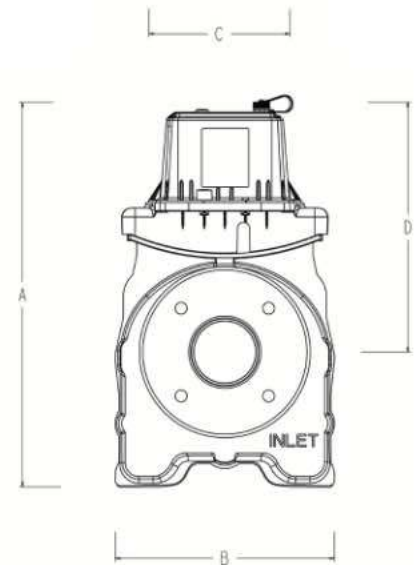
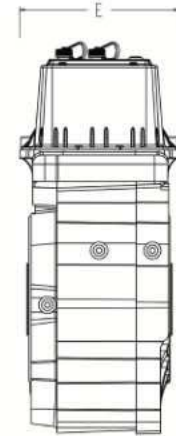

Dimensions fM2

Meter Sizing – fM3

Meter Size Base Rating	7M acfh (m ³ /h)	11M acfh (m ³ /h)	16M acfh (m ³ /h)	23M acfh (m ³ /h)	38M acfh (m ³ /h)	56M acfh (m ³ /h)
	7000 (198.2)	11000 (311.5)	16000 (453.1)	23000 (651.3)	38000 (1076.1)	56000 (1585.8)
Meter Pressure psig (Bar)	Metering Capacity MSCFH(m ³ /h)					
1 (0.07)	7.5 (211.7)	11.7 (332.6)	17.1 (483.8)	24.6 (695.5)	40.6 (1149.1)	
2 (0.14)	8.0 (225.1)	12.5 (353.8)	18.2 (514.6)	26.1 (739.7)	43.2 (1222.2)	63.6 (1801.1)
3 (0.21)	8.4 (238.6)	13.2 (374.9)	19.3 (545.4)	27.7 (783.9)	45.7 (1295.2)	67.4 (1908.7)
5 (0.34)	9.4 (265.5)	14.7 (417.2)	21.4 (606.9)	30.8 (872.4)	50.9 (1441.3)	75.0 (2124.1)
10 (0.69)	11.8 (332.8)	18.5 (523.0)	26.9 (760.7)	38.6 (1093.5)	63.8 (1806.6)	94.0 (2662.3)
15 (1.03)	14.1 (400.1)	22.2 (628.7)	32.3 (914.5)	46.4 (1314.5)	76.7 (2171.8)	113.0 (3200.6)
20 (1.38)	16.5 (467.4)	25.9 (734.4)	37.7 (1068.3)	54.2 (1535.6)	89.6 (2537.1)	132.0 (3738.9)
25 (1.72)	18.9 (534.6)	29.7 (840.2)	43.2 (1222.0)	62.0 (1756.7)	102.5 (2902.4)	151.0 (4277.2)
45 (3.10)	28.4 (803.8)	44.6 (1263.1)	64.9 (1837.2)	93.3 (2641.0)	154.1 (4363.4)	227.1 (6430.3)
60 (4.13)	35.5 (1005.6)	55.8 (1580.3)	81.2 (2298.6)	116.7 (3304.3)	192.8 (5459.2)	284.1 (8045.1)
90 (6.20)	49.8 (1409.4)	78.2 (2214.7)	113.8 (3221.4)	163.5 (4630.7)	270.2 (7650.8)	398.2 (11274.8)
100 (6.89)	54.5 (1543.9)	85.7 (2426.2)	124.6 (3529.0)	179.1 (5072.9)	296.0 (8381.3)	436.2 (12351.4)
150 (10.3)	78.3 (2216.8)	123.0 (3483.5)	178.9 (5066.9)	257.2 (7283.7)	425.0 (12033.9)	626.3 (17734.2)
175 (12.1)	90.2 (2553.2)	141.7 (4012.2)	206.1 (5835.9)	296.3 (8389.1)	489.5 (13860.2)	721.3 (20425.6)

Pressure loss across meter exceeds supply pressure

Pressure loss across meter in excess of 50% of supply pressure

Pressure Drop

0.6 specific gravity natural gas @ atmospheric pressure

Flowrate CFH (m ³ /h)	fM1, 2"	fM2, 2"	fM3, 3"	fM3, 4"
Pressure Loss in Inches W.C. (millibar)				
800 (22.7)	0.23 (0.57)	0.08 (0.20)	0.06 (0.15)	<0.01 (<0.01)
1000 (28.3)	0.35 (0.87)	0.11 (0.27)	0.08 (0.20)	<0.01 (0.01)
1500 (42.5)	0.75 (1.87)	0.22 (0.55)	0.17 (0.42)	0.02 (0.05)
2000 (56.6)	1.30 (3.24)	0.37 (0.92)	0.29 (0.72)	0.03 (0.07)
3000 (85.0)	2.85 (7.10)	0.78 (1.94)	0.61 (1.52)	0.09 (0.22)
5000 (141.6)	** (**)	2.02 (5.03)	1.62 (4.04)	0.26 (0.65)
7000 (198.2)	** (**)	3.85 (9.59)	3.12 (7.77)	0.54 (1.35)
11000 (311.5)	** (**)	9.27 (23.09)	7.56 (18.83)	1.38 (3.44)
16000 (453.1)	** (**)	** (**)	** (**)	2.99 (7.45)
23000 (651.3)	** (**)	** (**)	** (**)	6.26 (15.59)
38000 (1076.1)	** (**)	** (**)	** (**)	17.28 (43.04)
56000 (1585.8)	** (**)	** (**)	** (**)	37.76 (94.06)



At Itron, we're dedicated to delivering end-to-end smart grid and smart distribution solutions to electric, gas and water utilities around the globe. Our company is the world's leading provider of smart metering, data collection and utility software systems, with over 8,000 utilities worldwide relying on our technology to optimize the delivery and use of energy and water.

To realize your smarter energy and water future, start here: www.itron.com

CORPORATE HEADQUARTERS

2111 N Molter Road
Liberty Lake, WA 99019
USA

Phone: 1.800.635.5461

Fax: 1.509.891.3355