

REVISIONS

REV.	DESCRIPTION	DATE	APPROVED
------	-------------	------	----------

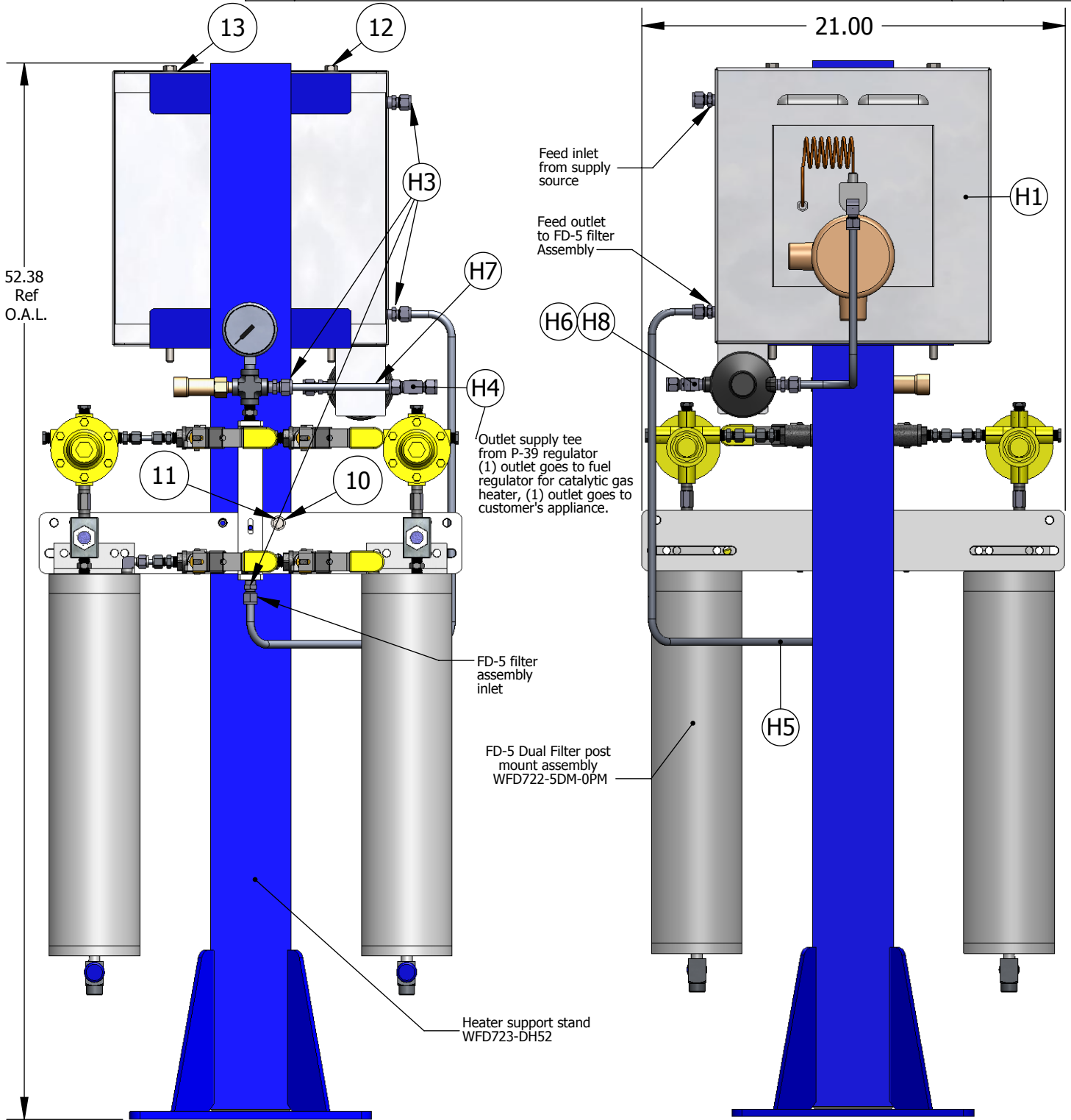

FRONT VIEW

REAR VIEW

PROPRIETARY AND CONFIDENTIAL
 THE INFORMATION CONTAINED IN THIS DRAWING IS THE SOLE PROPERTY OF IMAC SYSTEMS INC. ANY REPRODUCTION IN PART OR AS A WHOLE WITHOUT THE WRITTEN PERMISSION OF IMAC SYSTEMS INC. IS PROHIBITED.

		DIMENSIONS ARE IN INCHES TOLERANCES: FRACTIONAL ±1/32 ANGULAR: MACH ±1/2° BEND ±1/16 TWO PLACE DECIMAL ±.010 THREE PLACE DECIMAL ±.005			
		MATERIAL See Components			
		FINISH See Components			
NEXT ASSY	USED ON				
APPLICATION		DO NOT SCALE DRAWING			

	NAME	DATE
DRAWN	TH	4/11/11
CHECKED	JG	4/11/11
ENG APPR.		
MFG APPR.		
Q.A.		
COMMENTS:		

IMAC SYSTEMS INC.
 90 Main St. Tullytown, PA. 19007
 www.imacsystems.com 1-800-955-4GAS

Title: **Catalytic Gas Heater Dual Assembly**

SIZE A	DWG. NO. WFD723-5DMCH1	REV. N/A
SCALE:1:6	WEIGHT:	SHEET 1 OF 4