



CL31 Series Regulator

Commercial Regulator

The CL31 regulator can produce substantial savings for users in lower initial costs, lower installation costs and lower maintenance costs. Optimum valve design limits over boosting or rapid drop-off as the capacity requirement changes, including fast on-off loads.

The CL31 was designed for systems requiring highly accurate pressure regulation such as:

- » Utility “Fixed Factor” metering of relatively small loads (up to 4000 scfh)
- » Industrial Heating equipment requiring constant high burner pressures (1 psig to 20 psig)

DESCRIPTION

» CL31N

The CL31N is a constant pressure loaded regulator that utilizes a pilot with no internal relief (N). This regulator can be used where psig to psig regulation is required with no internal relief.

» CL31R

The CL31R is a constant pressure loaded regulator equipped with a pilot internal relief valve. The pilot relief valve is not designed for “full capacity” relief, but rather to limit the loading chamber pressure to a safe value in the event of failure.

» CL-31IMN

The CL31IMN is a constant pressure loaded regulator featuring Internal Monitoring (IM) operation with no pilot internal relief (N). It provides the important added advantage of a second, bubble-tight lock-up seat in series with the primary seat. If the primary seat fails to close or control the gas flow, the Internal Monitor seat assumes control of the downstream gas pressure.

» CL-31IMR

The CL31IMR provides the same features as the ‘IMN’ model but with token pilot relief valve backup of the monitor orifice if both the primary seat and monitor seat fail simultaneously.

» CL-31IMRV

Operation is identical to the ‘IMR’ except that at no flow position of the monitor orifice a small volume of gas is vented through the relief valve to serve as a signal that the regulator is on monitor operation and the primary seat has failed. No gas is vented until the

gas load is less than the volume going through the orifice vent hole and the regulator is on monitor operation.

- » Controlled size pilot breather orifice eliminates pulsation and provides normal breathing operation
- » “Stop stem” in pilot insures token internal relief valve operation
- » No special start-up procedures

FEATURES

- » Constant pressure loading provides “Fixed Factor” Measurement Accuracy Internal Bleed
- » Light closing spring for low lock-up
- » Wide outlet pressure range (1 psig to 20 psig)
- » One adjustable outlet spring (N version only)
- » Built in strainer screen in pilot regulator (N version only)
- » Extremely light weight
- » Compact design
- » Safety advantage of second gas tight lock-up seat with IM Version

CL31 SERIES COMMERCIAL REGULATOR

Shipping weight

Four regulators per box Box weight: 38 lbs.

CL31 DIMENSIONS (INCHES)

Valve Body	A	B	C	D	E	F	G	H	J
3/4 & 1	3-3/4	2-1/8	8	6-1/2	2	7-13/16	5-13/16	13	3
1-1/4	4	2-1/8							

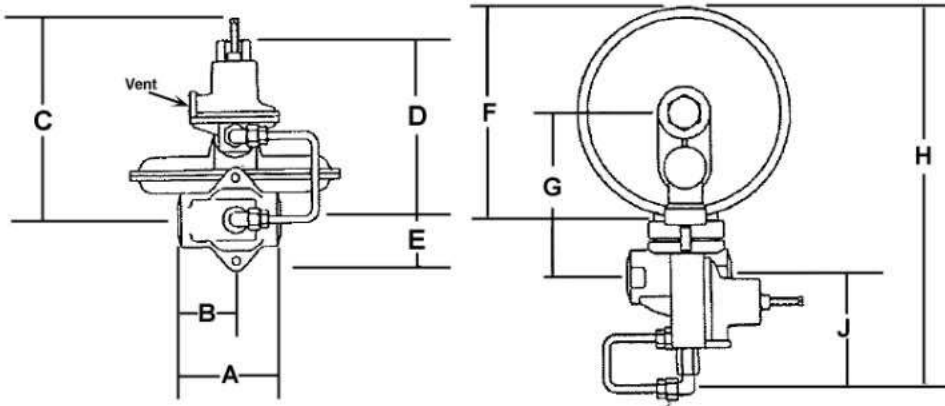

OPERATIONAL SCHEMATIC

Shown with N-type pilot

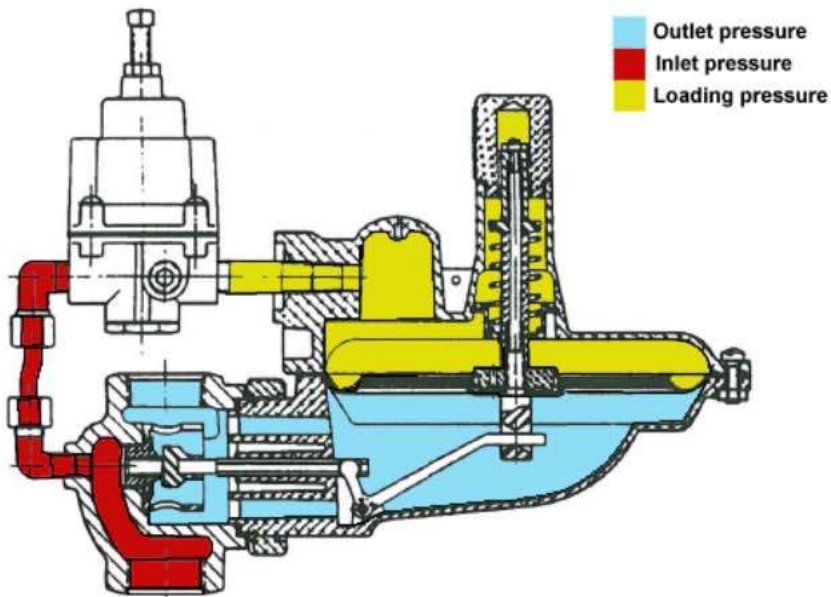

Note: valve shown in closed position.

SPRING DATA, SPRING COLOR OUTLET PRESSURE RANGE*

Spring Data, Spring Color Outlet Pressure Range*

Models CL31R, CL31MR, CL31IMRV	PSIG
Orange	1.0 to 1.6
Brown	1.6 to 2.6
Green	3.5 to 7.4
Black	3.8 to 13.3
Blue	4.6 to 21.5

Models CL31N, CL31IMN	PSIG
Blue	1 to 20

*WARNING Pilot springs are not interchangeable between N and R pilots.

ORIFICE DATA, WIDE OPEN FLOW COEFFICIENTS AND MAXIMUM PRESSURES

Orifice Size (inches)	K-Factor	Maximum Operating Inlet Pressure (PSIG)	Maximum Emergency Inlet Pressure (PSIG)	Maximum Emergency Outlet Pressure (PSIG)
1/8	35	125	175	
1/8 IM	30	125	175	
3/16	75	125	175	
3/16 IM	75	125	175	60
1/4	127	125	175	
1/4 IM	120	125	175	
3/8	290	60	90	
5/16 IM	150	60	90	

OPERATING TEMPERATURE RANGE

- -20°F to 150°F
- Silicone valve seats available for applications below -20°F

ADDITIONAL SPECIFICATIONS

Available Pilot Vent Sizes	1/4" NPT
Loading Ring Position	0 degrees
Closing Spring (non-adj.)	Light green only
Other Available Options	Seal wire to indicate unapproved tampering
	1/8" pipe plug tap on upstream side of valve body
	Pilot supply line filter (contact Itron, Owenton, KY)
	Stainless steel supply line fittings
	Teflon valve body gasket

CONSTRUCTION

Itron takes pride in delivering American made products with the utmost concern for safety, quality, and customer satisfaction.

Construction Materials

Closing spring	Music wire
Valve body	High tensile strength cast iron (ASTM A-126, Class A)
Orifice	Brass (ASTM B16, Alloy 360), aluminum - optional
Valve seat	Buna-N or silicone (for temperatures below -20°F)
Valve stem	Plated steel (Aluminum alloy 2011-T3)
Lever pin	Stainless steel (Type 303)
Lever	Zinc and dichromate plated steel (AISI C1010)
Upper diaphragm plate	Zinc and dichromate plated steel (14 gauge steel)
Lower diaphragm plate	Die cast aluminum (ASTM B-85 Alloy SC84A)
Diaphragm	Buna-N and nylon
Pilot vent screen	Stainless steel (16 mesh)
Adjustment ferrule	Die cast aluminum (ASTM CS43A)
Seal cap	Die cast aluminum (ASTM CS43A)
Diaphragm case	Die cast aluminum (ASTM B85-Alloy SC84A)

VALVE BODY SIZES (INCHES AND NPT THREAD TYPE)

Inlet	Outlet
3/4	3/4
3/4	1
3/4	1-1/4
1	1
1	1-1/4
1-1/4	1-1/4

CORRECTION FACTORS FOR NON-NATURAL GAS APPLICATIONS

The CL31 may be used to control gases other than natural gas. To determine the capacity for gases other than natural gas, multiply the values within the capacity tables by a correction factor. The table below lists the correction factors for some of the more common gases:

Gas Type	Specific Gravity	Correction Factor (CF)
Air	1.00	0.77
Butane	2.01	0.55
Carbon Dioxide (Dry)	1.52	0.63
Carbon Monoxide (Dry)	0.97	0.79
Natural Gas	0.60	1.00
Nitrogen	0.97	0.79
Propane	1.53	0.63
Propane-Air-Mix	1.20	0.71

To calculate the correction factor for gases not listed in the table above, use the gases' specific gravity and insert it in the formula listed below:

$$\text{Correction Factor (CF)} = \sqrt{\frac{SG_1}{SG_2}}$$

Where:

SG_1 = Specific gravity of the gas in which the capacity is published.

SG_2 = Specific gravity of the gas to be controlled.

Wide Open Flow Calculations

For wide-open orifice flow calculations use the following equations:

$$\text{For } \frac{P_1}{P_2} < 1.89 \quad \text{use: } Q = K\sqrt{P_2(P_1 - P_2)}$$

$$\text{For } \frac{P_1}{P_2} > 1.89 \quad \text{use: } Q = \frac{KP_1}{2}$$

Where: P_1 = Absolute Inlet Pressure (PSIA)

P_2 = Absolute Outlet Pressure (PSIA)

Q = Flow Rate (SCFH)

K = Orifice Coefficient (SCFH/PSI)

CL31 SERIES COMMERCIAL REGULATOR, MODELS N AND R

Capacity Table (1% Absolute Droop*)

Capacities in SCFH of 0.6 S.G. gas; base conditions of 14.7 PSIA and 60° F.

Typical Capacity Info.

Manufacturer	Itron
Type and model	CL31
Regulator	
Inlet size	1-1/4"
Outlet size	1-1/4"
Spring color	Varies
Position	5

Inlet Pressure (PSIG)	Outlet Pressure (PSIG)	Orifice Size			
		1/8"	3/16"	1/4"	3/8"
2	1		300	300	500
	3		400	500	905
3	2		325	350	1650
	5	325	550	850	1650
5	2	275	500	800	1450
	10	400	825	1450	2550
10	2	400	825	1450	2550
	5	400	625	1050	1700
	15	500	1025	1750	3300
15	2	500	1025	1750	3300
	5	500	1025	1700	2750
	10	400	700	1000	1700
20	1	575	1275	2100	3700
	2	575	1275	2100	3700
	5	575	1200	2100	3500
	10	500	1075	1750	3000
	15	400	825	800	1700
30	1	700	1600	2800	4000
	2	700	1600	2800	4000
	5	700	1600	2800	4000
	10	700	1600	2800	4000
	15	700	1450	2100	4000
	20	575	1200	1900	3200
40	1	900	1975	3400	4000
	2	900	1975	3400	4000
	5	900	1975	3400	4000
	10	900	1975	3400	4000
	15	900	1975	3300	4000
	20	900	1850	3300	4000
50	1	1075	2350	4000	4000
	2	1075	2350	4000	4000
	5	1075	2350	4000	4000
	10	1075	2350	4000	4000
	15	1075	2350	4000	4000
	20	1075	2350	4000	4000

Notes:

3/4-inch outlet pipe size limits the capacity to 2000 SCFH.

1-inch outlet pipe size limits to 3000 SCFH.

*Individual regulator performance may vary from data shown.

■ Inlet pressure is too low to achieve desired outlet pressure.

CL31 SERIES COMMERCIAL REGULATOR, MODELS N AND R (CONTINUED)

Capacity Table (1% Absolute Droop*)

Capacities in SCFH of 0.6 S.G. gas; base conditions of 14.7 PSIA and 60° F.

Typical Capacity Info.	
Manufacturer	Itron
Type and model	CL31
Regulator	
Inlet size	1-1/4"
Outlet size	1-1/4"
Spring color	Varies
Position	5

Inlet Pressure (PSIG)	Outlet Pressure (PSIG)	Orifice Size			
		1/8"	3/16"	1/4"	3/8"
60	1	1200	2675	4000	4000
	2	1200	2675	4000	4000
	5	1200	2675	4000	4000
	10	1200	2675	4000	4000
	15	1200	2675	4000	4000
	20	1200	2675	4000	4000
75	1	1400	3150	4000	
	2	1400	3150	4000	
	5	1400	3150	4000	
	10	1400	3150	4000	
	15	1400	3150	4000	
	20	1400	3150	4000	
100	1	1700	4000	4000	
	2	1700	4000	4000	
	5	1700	4000	4000	
	10	1700	4000	4000	
	15	1700	4000	4000	
	20	1700	4000	4000	
125	1	2100	4000	4000	
	2	2100	4000	4000	
	5	2100	4000	4000	
	10	2100	4000	4000	
	15	2100	4000	4000	
	20	2100	4000	4000	

Notes:

3/4-inch outlet pipe size limits the capacity to 2000 SCFH.

1-inch outlet pipe size limits to 3000 SCFH.

*Individual regulator performance may vary from data shown.

Do not operate orifice in shaded inlet pressure area.

CL31 PERFORMANCE CURVES

5, 10 PSIG Set Point

Type and model CL31R

Inlet size 1 1/4-inch NPT

Outlet size 1 1/4-inch NPT

Orifice size 1/4-inch

Set point 14.0" w.c. with 40 PSIG inlet @ 200 SCFH. All test results are reported at a base of 14.7 PSIG at 60° F and with 0.6 S.G. gas.

5 PSIG Set Point

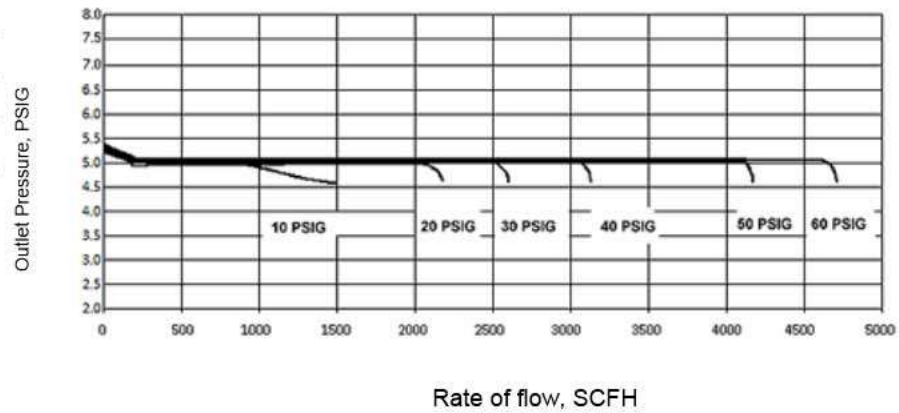

5, 10 PSIG Set Point

Type and model CL31R

Inlet size 1 1/4-inch NPT

Outlet size 1 1/4-inch NPT

Orifice size 1/4-inch

Set point 14.0" w.c. with 40 PSIG inlet @ 200 SCFH. All test results are reported at a base of 14.7 PSIG at 60° F and with 0.6 S.G. gas.

10 PSIG Set Point

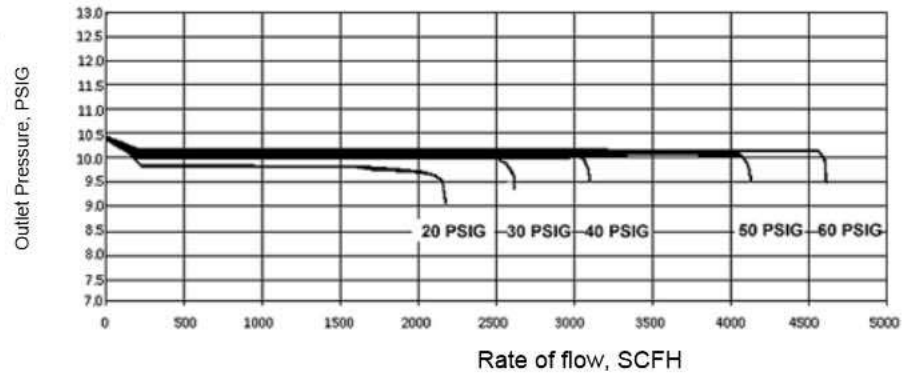

CL34 IM INTERNAL MONITOR* SERVICE REGULATOR

General Description

The CL31 IM regulator is designed specifically to comply with BOT OPS 192.197, paragraph B which states, "or if the gas contains materials that seriously interfere with the operation of a service regulator, there must be suitable protective devices to prevent unsafe over-pressuring of the customer's appliance, if the service regulator fails." The code lists the devices, one of which is the regulator and monitor. The code further states these devices may be installed as an internal part of the service regulator or as a separate unit. The internal monitor (IM) is a single valve body regulator with built-in monitor operation. It features the safety advantage of a second gas tight lock-up seat if the normal orifice face and valve seat fail to product the adjusted outlet pressure. The monitor also controls gas flow between the failed open flow and no flow; providing complete secondary regulation and monitor regulation function without relieving gas to the atmosphere or shutting off the gas flow to the customer. The monitor overpressure takeover is a 2" w.c. increase on regulators set for 6 to 9" w.c., a 0.5 PSIG increase on regulators set for 2 PSIG, and 1 PSIG increase on regulators set for 5 PSIG.

*Patent numbers 3,613,725 and 3,751,570.

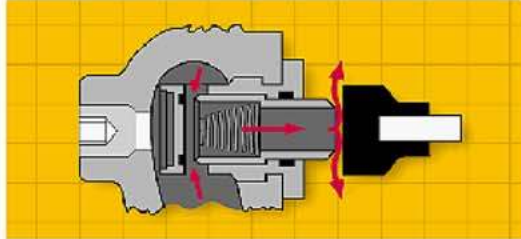

A. Standard regulator and upstream monitor orifice.

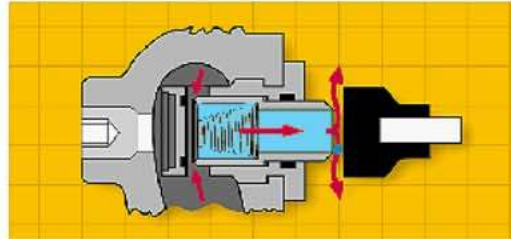

B. Standard regulator orifice failed; upstream monitor orifice control.

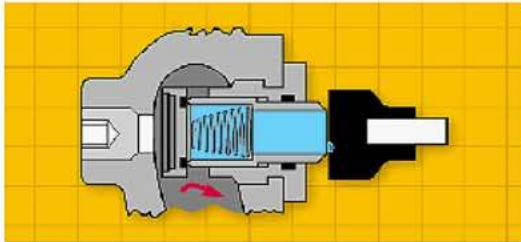

C. Main orifice failed - upstream monitor orifice lock-up.

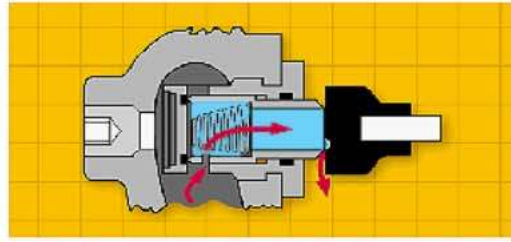

D. V option - vents a small volume of gas to atmosphere through relief valve.

Inlet pressure

Outlet pressure

PRINCIPLE OF OPERATION

A. Normal operation. The internal monitor IM orifice performs like a standard regulator and monitor regulator in that main orifice and valve seat actuate to control outlet flow and pressure under normal flow conditions. If there is no demand, the main seat and internal monitor orifice will close.

B. Monitor operation. If the main valve seat fails to control the gas flow and pressure due to foreign matter between the seat and orifice face, or if the seat is eroded, the internal monitor orifice automatically goes into operating position at a slightly higher outlet pressure (see Internal Monitor Lock-up Pressure table). Any time the pressure on the main diaphragm exceeds the force of the fixed monitor spring, the increased outlet pressure causes the main valve seat to push against the sliding orifice. The sliding orifice compresses the monitor spring and positions the monitor orifice to control the gas flow. The IM orifice now functions as a monitor regulator and continues to monitor as long as the main seat fails to control at the normal adjusted outlet pressure. If the gas load demand is increased beyond the internal monitor's capacity, the outlet pressure is reduced to normal adjusted pressure and the regulator resumes normal regulation.

C. Monitor lock-up. If the demand for gas is decreased to zero flow during monitor operation, the sliding orifice continues to close until its orifice is in the gas tight position (monitor lock-up) against the BUNA-N monitor valve seat. (See the Internal Monitor Lock-up Pressure table for the outlet pressure required for internal monitor lock-up.)

D. Vent hole V option. On installations where a small volume of over-pressure gas can be safely vented to the atmosphere, the advantages of both the pilot relief valve and monitor safety can be combined. If the flow is decreased to zero or just greater than zero, the vent hole in the internal monitor orifice allows gas to slowly bleed downstream and cause the pressure to rise to the relief point of the pilot's internal relief valve. The gas then bleeds to the atmosphere indicating a problem with the regulator.

INTERNAL MONITOR LOCK-UP PRESSURE

Outlet pressure set point (PSIG)	Pilot spring	IM lock-up pressure (PSIG)
1	Orange	1.5
2	Brown	2.5
5	Green	5.6
10	Black	10.8
15	Blue	16.2
20	Blue	21.2

Note The above tests were conducted using a 0.1-inch diameter nylon rod glued to the valve seat.

CL31 SERIES COMMERCIAL REGULATOR, MODELS IMR, IMRV, AND IMN

Capacity Table (1% Absolute Droop*)

Capacities in SCFH of 0.6 S.G. gas; base conditions of 14.7 PSIA and 60° F.

Typical Capacity Info.	
Manufacturer	Itron
Type and model	CL31 IM
Regulator	
Inlet size	1-1/4"
Outlet size	1-1/4"
Spring color	Varies
Position	5

Inlet Pressure (PSIG)	Outlet Pressure (PSIG)	Orifice Size			
		1/8"	3/16"	1/4"	5/16"
2	1		300	300	300
	3				
3	1		400	475	500
	2		300	325	350
5	1	325	550	675	850
	2	275	500	600	680
10	1	400	825	1050	1250
	2	400	825	1025	1250
	5	400	625	850	1000
15	1	500	1025	1400	1650
	2	500	1025	1375	1650
	5	500	950	1275	1525
	10	400	625	900	1050
20	1	575	1200	1700	2000
	2	575	1200	1700	2000
	5	575	1200	1625	2000
	10	500	1050	1200	1725
	15	400	750	900	1250
30	1	700	1575	2275	2700
	2	700	1575	2275	2700
	5	700	1575	2250	2700
	10	700	1575	2050	2550
	15	700	1450	1900	2275
	20	575	1200	1625	1950
40	1	900	1900	2850	3300
	2	900	1900	2850	3300
	5	900	1900	2850	3300
	10	900	1900	2750	3300
	15	900	1900	2575	3100
	20	900	1775	2500	3000
50	1	1075	2250	3400	4000
	2	1075	2250	3400	4000
	5	1075	2250	3400	4000
	10	1075	2250	3300	4000
	15	1075	2250	3250	4000
	20	1075	2200	3175	4000

Notes

3/4-inch outlet pipe size limits the capacity to 2000 SCFH.

1-inch outlet pipe size limits the capacity to 3000 SCFH.

*Individual regulator performance may vary from data shown.

█ Inlet pressure is too low to achieve desired outlet pressure.

CL31 SERIES COMMERCIAL REGULATOR, MODELS IMR, IMRV, AND IMN (CONTINUED)

Capacity Table (1% Absolute Droop*)

Capacities in SCFH of 0.6 S.G. gas; base conditions of 14.7 PSIA and 60° F.

Typical Capacity Info.	
Manufacturer	Itron
Type and model	CL31 IM
Regulator	
Inlet size	1-1/4"
Outlet size	1-1/4"
Spring color	Varies
Position	5

Inlet Pressure (PSIG)	Outlet Pressure (PSIG)	Orifice Size			
		1/8"	3/16"	1/4"	5/16"
60	1	1200	2575	3900	4000
	2	1200	2575	3900	4000
	5	1200	2575	3900	4000
	10	1200	2575	3900	4000
	15	1200	2575	3900	4000
	20	1200	2575	3900	4000
75	1	1400	3075	4000	
	2	1400	3075	4000	
	5	1400	3075	4000	
	10	1400	3075	4000	
	15	1400	3075	4000	
	20	1400	3075	4000	
100	1	1700	3600	4000	
	2	1700	3600	4000	
	5	1700	3600	4000	
	10	1700	3600	4000	
	15	1700	3600	4000	
	20	1700	3600	4000	
125	1	2100	4000	4000	
	2	2100	4000	4000	
	5	2100	4000	4000	
	10	2100	4000	4000	
	15	2100	4000	4000	
	20	2100	4000	4000	

Notes

3/4-inch outlet pipe size limits the capacity to 2000 SCFH.

1-inch outlet pipe size limits the capacity to 3000 SCFH.

*Individual regulator performance may vary from data shown.

Do not operate orifice in shaded inlet pressure area.

ASSEMBLY POSITIONS

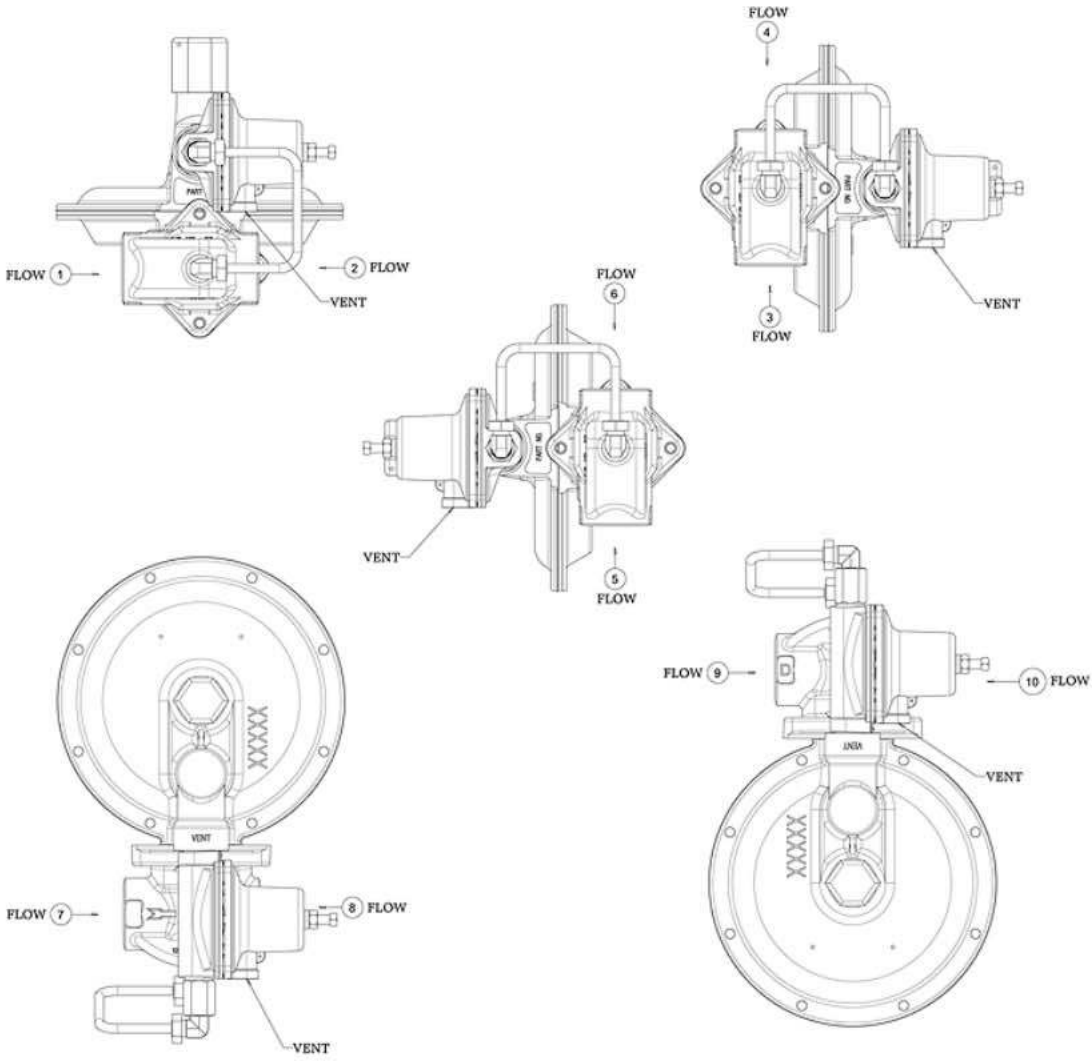

CL31 SERIES REGULATORS, R AND N MODELS

CL31 R

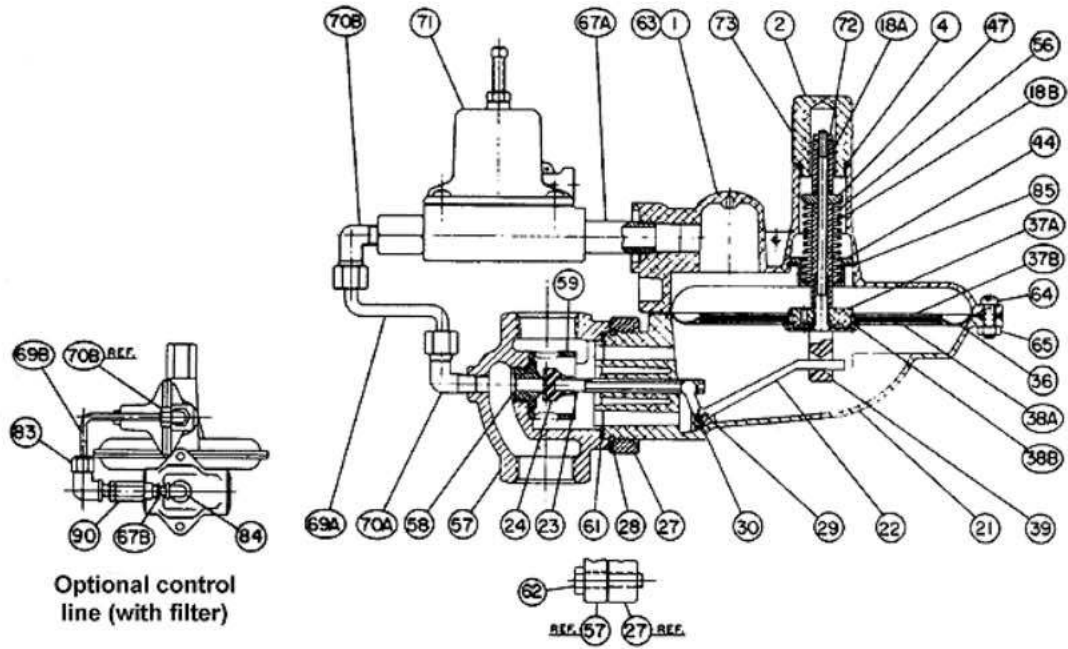

Optional control line (with filter)

CL31 N

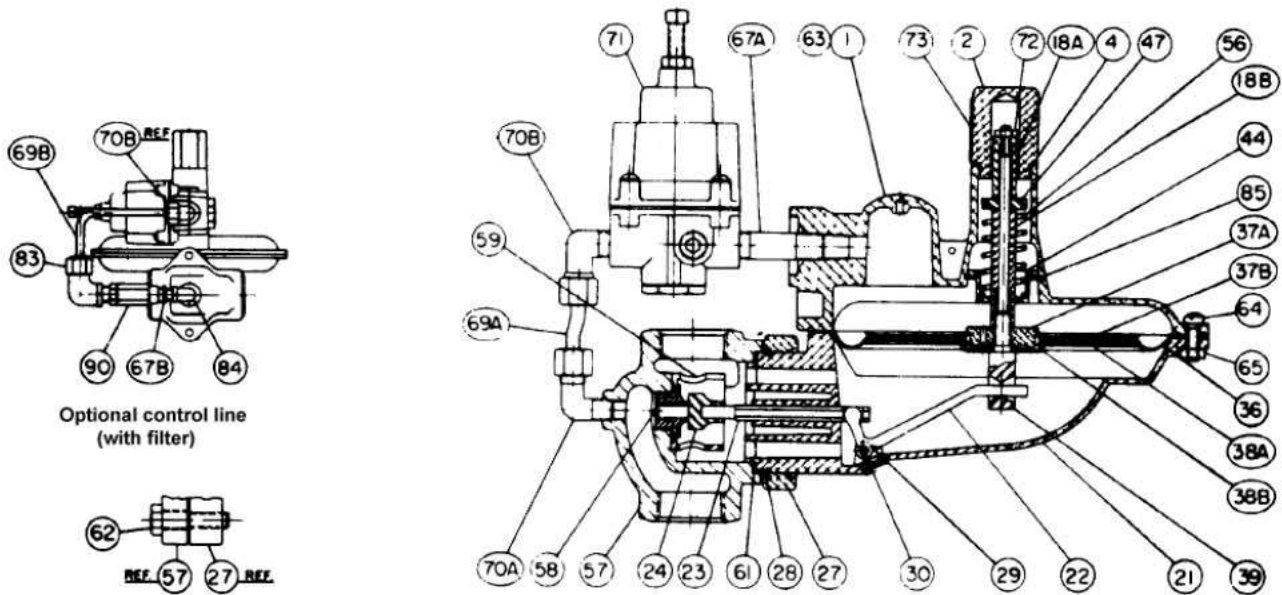

Optional control line (with filter)

PARTS LIST

Item No.	Part No.	Quantity Required per Regulator Model		Description
		N	R	
1	753194	1		Upper diaphragm case, vent 1/4" pipe
	753199	1	1	Upper diaphragm case, vent 3/8" pipe
2		1	1	Seal cap, please specify
	760001			With seal wire hole
	760011			Without seal wire hole
4	765503	1	1	Seal cap gasket
18A	754721	1	1	Stop stem spacer, upper
18B	754725	1	1	Stop stem spacer, lower
21	752124	1	1	Lower diaphragm case, 4:1 lever ratio
22	761231	1	1	Valve linkage lever, 4:1 lever ratio
23	754021	1	1	Valve stem
24	765027	1	1	Valve seat, Buna N, standard
27	751913	1	1	Valve body retainer plate, aluminum
28	755725	1	1	Retainer plate snap ring
29	755141	2	2	Valve linkage pin screw
30	754831	1	1	Valve linkage pin
36	766121	1	1	Diaphragm
37A	761031	1	1	Upper diaphragm plate
37B	761025	1	1	Upper diaphragm plate, steel
38A	761025	1	1	Lower diaphragm plate, steel
38B	756091	1	1	Lower diaphragm plate
39	754331	1	1	Stop stem
44	754901	1	1	Stop stem guide bushing
47	761495	1	1	Closing spring guide
56	762119	1	1	Closing spring, light green
	57	1	1	Valve bodies. Straight. Please specify size
	750060			3/4" x 3/4" NPT with 1/8" NPT
	750069			3/4" x 1" NPT with 1/8" NPT
	750078			1" x 1" NPT with 1/8" NPT
	750110			3/4" x 1-1/4" NPT with 1/8" NPT
	750119			1" x 1-1/4" NPT with 1/8" NPT
	750134			1-1/4" x 1-1/4" NPT with 1/8" NPT
58		1	1	Orifice, brass. Please specify size.
	757255			1/8" Diameter
	757259			3/16" Diameter
	757263			1/4" Diameter
	757271			3/8" Diameter
59	761753	1	1	Loading ring
61	765753	1	1	Valve body gasket
62	755386	2	2	Retainer plate screw, hex head, 5/16", 18 x 1-1/4" Lg.
63	769205	1	1	Curved regulator plate
64	755304	8	8	Case screw, hex head, 1/4", 20 x 3/4"
65	755661	8	8	Case nut, hex head, 1/4", 20
67A	768133		1	Nipple, 3/8" NPT x 2"
	768123	1		Nipple, 1/4" NPT x 2"

Item No.	Part No.	Quantity Required per Regulator Model		Description
		N	R	
67B	768101	1	1	Pipe nipple, male, 1/8" x 1/4" NPT steel
69A	768507	1	1	Control line, 1/4" steel
69B	768541	1	1	Control line, 1/4" D tube, steel
70A	768251	1	1	90° Male elbow, 1/4" tube x 1/8" NPTF, steel
70B	768257	1	1	90° Male elbow, 1/4" tube x 1/4" NPTF, steel
				*Optional control line with filter assembly. Call Itron, Owenton, KY
71	700321	1		Pilot assembly, N version only, blue spring
	762631		1	Orange, adjustment spring only
	762633		1	Brown, adjustment spring only
	762635		1	Green, adjustment spring only
	762637		1	Black, adjustment spring only
	762639		1	Blue, adjustment spring only
72	755621	1	1	Stop stem nut (Hex) #10-24
73	769401	1	1	Warning sticker, seal cap
83	766273	1	1	90° Female elbow, 1/4" tube x 1/4" NPT, steel
84	768291	1	1	90° Street elbow, 1/4" NPT, steel
85	755731	1	1	Stem guide bushing retainer ring
90	768481	1	1	Control line filter
CL31 Repair Kit 770033				
	765027	1		Valve seat 85 Duro IM (white stripe)
	765503	1		Seal cap O-ring
	765753	1		Valve body gasket pilot
	766001	1		Diaphragm pilot
	766130	1		Diaphragm with O-ring seal

VENT LINES FOR REGULATORS

When constructing vent lines to be attached to regulators installed indoors, follow a few basic rules:

- a. Never use pipe sizes smaller than the vent size; smaller pipe sizes restrict the gas flow. If a long gas run must be used, Itron advises increasing the pipe one nominal size every ten feet to keep the flow restriction as low as possible.
- b. Keep the vent line length as short as possible to minimize the restriction and reduce the vent's tendency to cause regulator pulsation.
- c. Support the vent pipe to eliminate strain on the regulator diaphragm case.
- d. Always point outdoor vent pipes in the downward position to reduce the possibility of rain, snow, sleet, and other moisture entering the pipe. Install a bug screen in the end of the pipe.
- e. Do not locate the vent line terminus near windows, fans, or other ventilation equipment. See the installation instructions furnished with the regulator.
- f. Adhere to all applicable codes and regulations.
- g. If your vent pipe causes regulator pulsation, consult your sales representative or manufacturer.
- h. Itron strongly recommends running a separate vent line for each regulator. Headers with various installed devices can cause regulator malfunction.

Caution Ensure the end of the vent line is away from ANY potential ignition sources. It is the installer's responsibility to verify the vent line is exhausting to a safe environment.

INSTALLATION

Warning Itron does not endorse or warrant the completeness or accuracy of any third party regulator installation procedures or practices, unless otherwise provided in writing by Itron. Follow your company's standard operating procedures regarding the use of personal protection equipment (PPE). Adhere to guidelines issued by your company in addition to those given in this document when installing regulators.

- a. Remove all shipping plugs from the regulator inlet, outlet, and vent before installation.
- b. Verify the piping interior and regulator inlet and outlet are clean and free of dirt, pipe dope, and other debris. Dirt and other foreign materials entering the regulator can cause a loss of pressure control.
- c. Apply pipe joint sealant to the male pipe threads. Do not use pipe joint material on the regulator's female threads. Joint sealant could become lodged in the regulator and cause a loss of pressure control.
- d. Gas must flow through the regulator's valve body in the direction cast on the regulator body. Gas flowing in the wrong direction can overpressure and cause damage to the regulator.
- e. The pilot diaphragm casing can be mounted in any position relative to the body through a full 360° angle at 90° increments.
- f. When the regulator is installed OUTDOORS, the vent must always be positioned so that rain, snow, moisture or foreign particles cannot enter the vent opening. Itron recommends positioning the pilot vent downward to avoid entry of water or other matter which could interfere with the proper operation of the regulator. The vent should be located away from building eaves, window openings, building air intakes and above the expected snow level at the site. The vent opening should be inspected periodically to insure it does not become blocked by foreign material as outlined in DOT PHMSA-RSPA-2004-19856.
- g. When the regulator is installed INDOORS, the vent must be piped to the outside atmosphere using the shortest length of pipe, the fewest possible pipe elbows, and a pipe diameter as large as the vent size or larger. USING VENT PIPE SMALLER THAN THE VENT CONNECTION LIMITS THE REGULATOR'S INTERNAL RELIEF VALVE CAPACITY. The outlet end of the pipe must be protected from moisture and the entrance of foreign particles. The regulator should be specified by the user with the size vent and pipe threads desired to make the vent pipe connection.

START-UP PROCEDURE

- a. Mount a pressure gauge downstream of the regulator to monitor the downstream pressure.
- b. With the downstream pressure valve closed, slowly open the inlet valve. The outlet pressure should rise to slightly more than the set-point. Verify there are no leaks and all connections are tight.
- c. The regulator was pre-set at the factory to match order specifications. If necessary, adjust the outlet pressure by removing the seal cap on the top of the pilot spring housing and adjusting the ferrule or screw inside the pilot spring housing using a large flat-head screwdriver. With a small amount of gas flowing through the regulator, rotate the pilot ferrule clockwise to raise the outlet pressure or counter-clockwise to lower the outlet pressure.
- d. Replace the seal cap and check for leaks after the desired outlet pressure is achieved.

The regulator is ready for operation.

SAFETY WARNING

This product, as of the date of manufacture, is designed and tested to conform to all governmental and industry safety standards as they may apply to the manufacturer. The purchaser/user of this product must comply with all fire control, building codes, and other safety regulations governing the application, installation, operation, and general use of this regulator to avoid leaking gas hazards resulting from improper installation, startup or use of this product.

Itron strongly recommends installation by a qualified professional and periodic inspection of pressure regulators (inspections may be required by local applicable codes or regulations).

Inspections should include checking for gas quality, cycle numbers, external environmental changes, and operating conditions that impact wear on the regulator's moving parts. To ensure safe and efficient operation of this product, replace worn or damaged parts found during inspection.

LIMITED WARRANTY

Itron, Inc. 970 Highway 127 North, Owenton, Kentucky 40359-9302, warrants this gas product against defects in materials and workmanship for the earlier of one (1) year from the date the product is shipped by Itron or a period of one year from the date the product is installed by Itron at the original purchaser's site. During such one-year period, provided that the original purchaser continues to own the product, Itron will, at its sole option, repair any defects, replace the product or repay the purchase price.

» This warranty will be void if the purchaser fails to observe the procedures for installation, operation or service of the product as set forth in the Operating Manual and Specifications for the product or if the defect is caused by tampering, physical abuse or misuse of the product.

- » ITRON SPECIFICALLY DISCLAIMS ALL IMPLIED WARRANTIES INCLUDING THOSE OF MERCHANTABILITY OR OF FITNESS FOR PARTICULAR PURPOSE. UNDER NO CIRCUMSTANCES WILL ITRON BE LIABLE FOR INCIDENTAL OR CONSEQUENTIAL DAMAGES OF ANY KIND WHATSOEVER.
- » Itron's liability for any claim of any kind, including negligence and breach of warranty for the sale and use of any product covered by or furnished, shall in no case exceed the price allocable to the product or part thereof which gives rise to the claim.
- » In the event of a malfunction of the product, consult your Itron Service Representative or Itron Inc., 970 Highway 127 North, Owenton, Kentucky 40359-9302. See Itron Terms and Conditions of Sale for the full and complete terms of the Limited Warranty.

ORDERING INFORMATION

1. Inlet and outlet connection size and type
2. Model number
3. Outlet pressure desired
4. Inlet pressure range
5. Type of gas and maximum capacity required
6. Assembly position number (see diagram above)
7. Vent size
8. Special requirements such as tagging, pipe plug tap, seal wire, etc.



At Itron, we're dedicated to delivering end-to-end smart grid and smart distribution solutions to electric, gas and water utilities around the globe. Our company is the world's leading provider of smart metering, data collection and utility software systems, with over 8,000 utilities worldwide relying on our technology to optimize the delivery and use of energy and water.

To realize your smarter energy and water future, start here: www.itron.com

CORPORATE HEADQUARTERS

2111 N Molter Road
Liberty Lake, WA 99019
USA

Phone: 1.800.635.5461
Fax: 1.509.891.3355