



B34S Series Regulator

Medium Duty Commercial and Industrial Regulator

Appropriate for many commercial and industrial uses such as gas engines, burners, furnaces and boilers. The rapid response of the B34 is particularly well-suited for mid-range applications where quick on/off loads cause shock problems.

MODEL DESCRIPTION

- » The B34S is a spring-loaded, self operated regulator available with or without internal relief. It combines the B31 8" diaphragm case with the B34 valve assembly for an economical solution to mid-range commercial and industrial applications. Among its attributes are an adjustable loading ring for controlled boost at high flows, precision breather opening to ensure proper stability under all conditions, and, in the R model, a high capacity internal relief valve. All critical parts are either steel or aluminum to ensure reliability.
- » B34SN – The B34SN is a spring-loaded, self-operated regulator with no internal relief. This regulator can be used on mid-range applications where an internal relief or other type of over-pressure protection device is not required.

- » B34SR – The B34SR is the internal relief version of the B34S series. This model features an internal relief valve with a 1" vent.

FEATURES

- » Interchangeable brass orifice
- » 27 in² of diaphragm area
- » Molded diaphragm consisting of Buna-N and nylon
- » Upper diaphragm plate of plated steel
- » Stainless steel lever pin
- » Zinc with dichromate plated steel lever
- » One piece molded Buna-N valve seat
- » Alodined aluminum valve stem
- » Delrin® vent valve with Buna-N seat
- » Spring-loaded internal relief valve assembly

- » Vent Sizes: 1/4", 3/8", 3/4", and 1"
- » Stainless steel vent screen
- » Die cast aluminum seal cap
- » Field interchangeable adjustment spring
- » Controlled size breather orifice eliminates pulsation and provides normal action at low flows
- » Wide range of valve body sizes including NPT and flange connections
- » CGA 6-18 approved

BENEFITS

- » Economical
- » Protects equipment from shock damage
- » Space saving design
- » Commercial performance in a compact size

SHIPPING WEIGHT

Eight regulators per box Box weight: 100 lbs.

B34S DIMENSIONS (INCHES)

Valve Body	A	B	C	D	E	F	G	R
NPT	5-1/4	2-7/8	6	7-13/16	3-1/4	4-7/8	4-1/2	2-1/4
Flanged	10	5	---	---	---	---	5-1/2	3-1/4

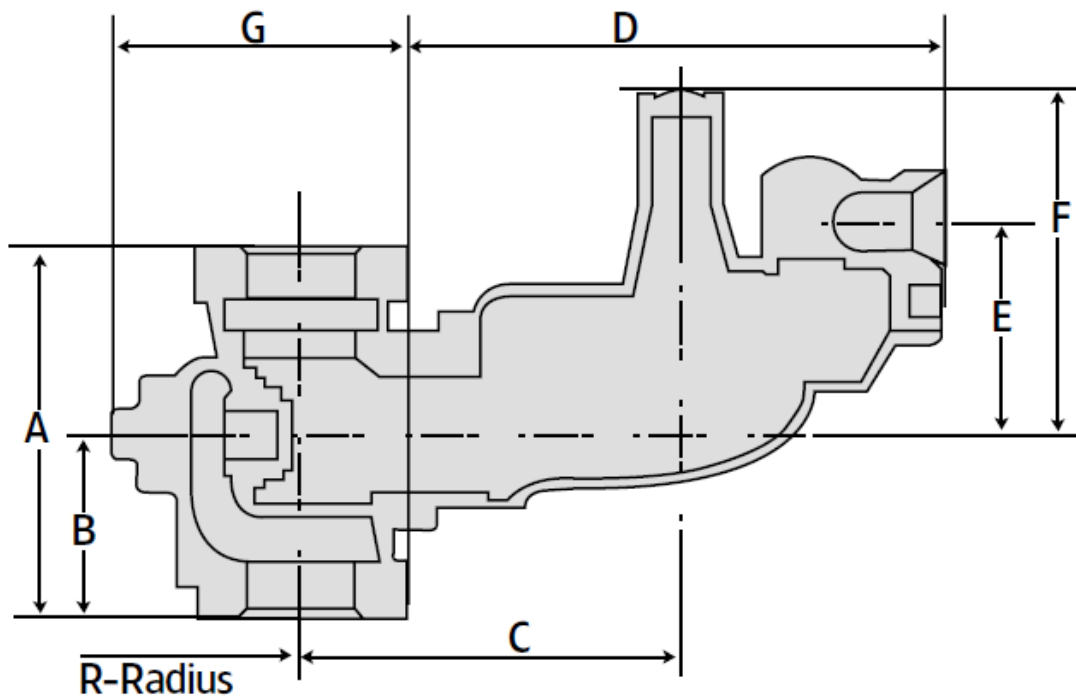

OPERATIONAL SCHEMATIC

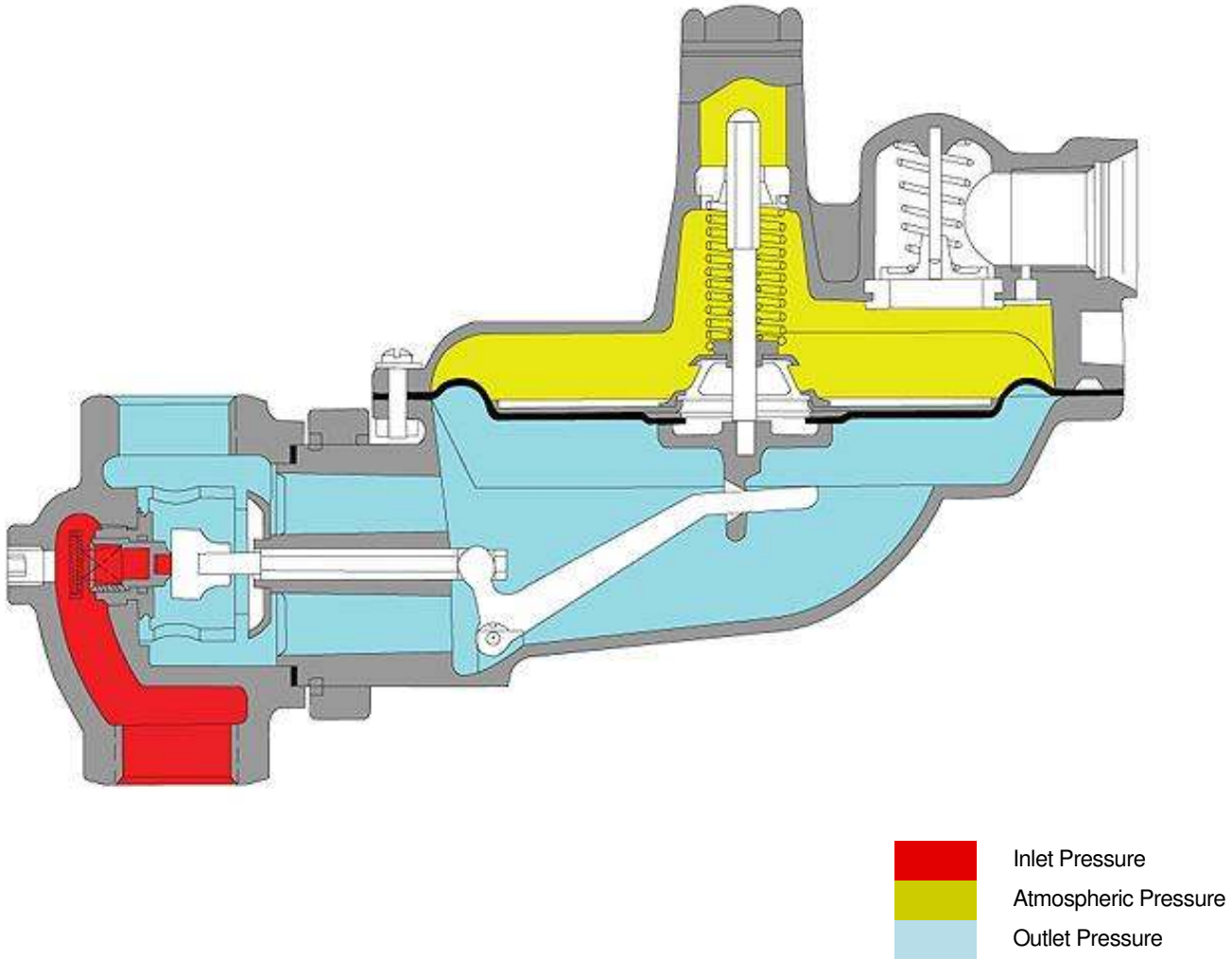

SPRING DATA - SPRING COLOR OUTLET PRESSURE RANGE

Models B34SR & SN	Inches w.c.
Brown	3.5 to 5.0
Dark Green	4.5 to 6.5
Light Green	5.5 to 7.5
Black	6.0 to 9.0
Blue	8.5 to 12.5
Silver	11.0 to 17.0
Model B34S RHP & B34SNHP	PSIG
Red/Gray	1.0
Yellow	1.2-1.5
Red	1.5-1.9
White	1.75-2.5

B34SR only: Relief spring setting of 7" w.c. above set pressure is standard. Special springs available on request. The relief vent is available in 1/4", 3/8", 3/4", and 1" and threaded with a female NPT connection.

ORIFICE DATA - WIDE OPEN FLOW COEFFICIENTS AND MAXIMUM PRESSURES

Orifice Size (inches)	K-Factor	Maximum Inlet Pressure (PSIG)
1/4 x 3/8	125	100
3/8 x 1/2	305	50
1/2 x 5/8	530	25
5/8 x 3/4	750	15
3/4 x 7/8	950	10
7/8 x 1	1100	10

OPERATING TEMPERATURE RANGE

- 20°F to 150°F
- Silicone valve seats available for applications below -20°F

ADDITIONAL SPECIFICATIONS

Available Vent Sizes:	1/4", 3/8", 3/4", and 1"
Loading Ring Position:	For outlet pressure < 1 PSIG, set point 0° For outlet pressure > 1 PSIG, set point 15°
Other Available Options:	Seal wire to indicate unapproved tampering 1/8" pipe plug tap on upstream side of valve body Teflon valve body gasket

CONSTRUCTION

Itron takes pride in delivering American made products with the utmost concern for safety, quality, and customer satisfaction.

Material Construction

Valve body	High tensile strength cast iron (ASTM A-126, Class A)
Orifice	Brass
Valve seat	Buna-N or silicone
Valve stem	Alodined aluminum
Lever pin	Stainless steel
Lever	Zinc and dichromate plated steel
Stem Guide	Aluminum
Upper diaphragm plate	Zinc and dichromate plated steel
Lower diaphragm plate	Die cast aluminum
Diaphragm	Buna-N on Dacron molded to shape
Vent valve/seat	Delrin/Buna-N
Vent screen	Stainless steel
Adjustment ferrule	Delrin
Seal cap	Die cast aluminum
Diaphragm case	Die cast aluminum

VALVE BODY SIZES (INCHES)

Inlet	Outlet	NPT	Flanged
1-1/4	1-1/4	X	---
1-1/4	1-1/2	X	---
1-1/4	2	X	---
1-1/2	1-1/2	X	---
1-1/2	2	X	---
2	2	X	X
3	3	---	X

Note: X indicates that the valve body is available in that configuration.

CORRECTION FACTORS FOR NON-NATURAL GAS APPLICATIONS

The B34S may be used to control gases other than natural gas. To determine the capacity for gases other than natural gas, multiply the values within the capacity tables by a correction factor. The table below lists the correction factors for some of the more common gases:

Gas Type	Specific Gravity	Correction Factor (CF)
Air	1.00	0.77
Butane	2.01	0.55
Carbon Dioxide (Dry)	1.52	0.63
Carbon Monoxide (Dry)	0.97	0.79
Natural Gas	0.60	1.00
Nitrogen	0.97	0.79
Propane	1.53	0.63
Propane-Air-Mix	1.20	0.71

To calculate the correction factor for gases not listed in the table above, use the gases' specific gravity and insert it in the formula listed below:

$$\text{Correction Factor (CF)} = \sqrt{\frac{SG_1}{SG_2}}$$

Where:

SG₁ = Specific gravity of the gas in which the capacity is published.

SG₂ = Specific gravity of the gas to be controlled.

Wide Open Flow Calculations

For wide-open orifice flow calculations use the following equations:

$$\text{For } P_1/P_2 < 1.89 \text{ use: } Q = K\sqrt{P_2(P_1 - P_2)} \quad \text{For } P_1/P_2 \geq 1.89 \text{ use: } Q = \frac{KP_1}{2}$$

Where:

P₁ = Absolute Inlet Pressure (PSIA)

P₂ = Absolute Outlet Pressure (PSIA)

Q = Flow Rate (SCFH)

K = Orifice Coefficient (SCFH/PSI)

B34S SERIES COMMERCIAL REGULATOR – MODELS SN AND SR

Capacity Table 7" w.c. (1" Droop*)

Typical Capacity Info.

Manufacturer	Itron
Type and model	B34SR
Regulator	
Inlet size:	2" NPT
Outlet size:	2" NPT

Capacities in SCFH of 0.6 S.G. gas; base conditions of 14.7 PSIA and 60° F.

Inlet Pressure PSIG	Orifice Size					
	1/4" x 3/8"	3/8" x 1/2"	1/2" x 5/8"	5/8" x 3/4"	3/4" x 7/8"	7/8" x 1"
1	460	720	940	1180	1360	1540
2	700	1080	1520	1830	2200	2300
3	860	1420	2100	2520	3000	3420
5	1120	1960	3000	3820	4550	5150
8	1360	2860	4400	5600	6600	7500
10	1520	3280	5250	6600	>7500	>7500
15	1860	3980	6950	>7500		
25	2520	5250	>7500			
35	3260	6600				
50	4080	>7500				
75	5665					
100	7250					

Notes:

*Individual regulator performance may vary from data shown.



Do not operate orifice in shaded inlet pressure area.

B34S Performance Curves

7" w.c. Set Point

Type and model	B34S R
Inlet size	2" NPT
Outlet size	2" NPT
Orifice size	1/4" x 3/8"

All test results are reported at a base of 14.7 PSIA at 60° F and with 0.6 S.G. gas.

B34S Relief Curves

7" w.c. Set Point

Inlet size	2" NPT
Outlet size	2" NPT
Vent size	1" NPT

All test results are reported at a base of 14.7 PSIA at 60° F and with 0.6 S.G. gas.

Performance Curves

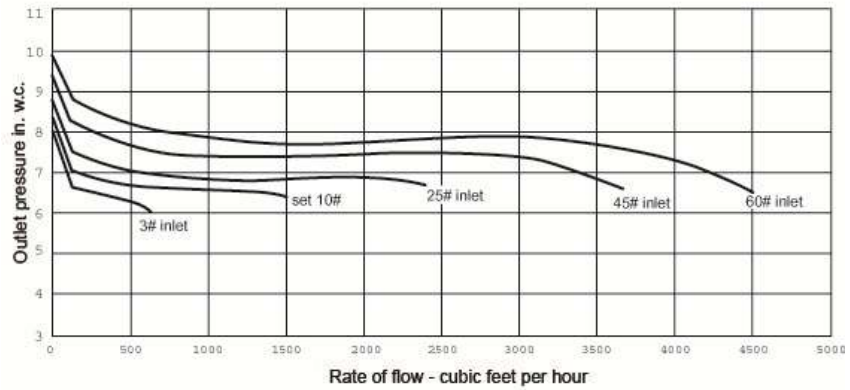

Relief Curves

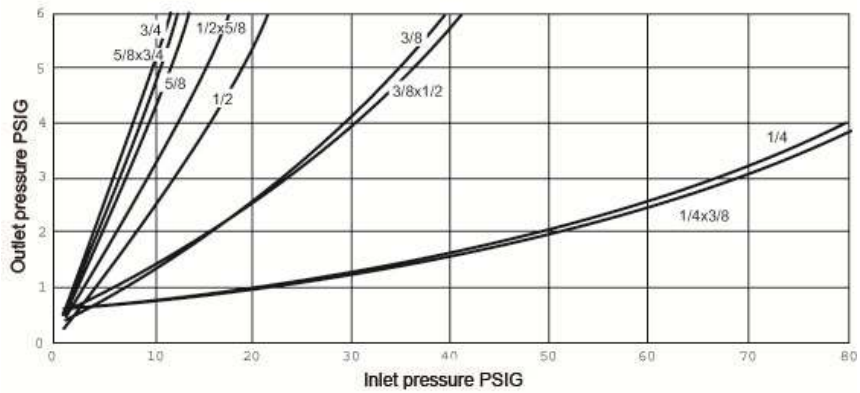

B34S SERIES COMMERCIAL REGULATOR – MODELS SN AND SR

Capacity Table 14" w.c. (2" Droop*)

Typical Capacity Info.

Manufacturer	Itron
Type and model	B34SR
Regulator	
Inlet size:	2" NPT
Outlet size:	2" NPT

Capacities in SCFH of 0.6 S.G. gas; base conditions of 14.7 PSIA and 60° F.

Inlet Pressure PSIG	Orifice Size					
	1/4" x 3/8"	3/8" x 1/2"	1/2" x 5/8"	5/8" x 3/4"	3/4" x 7/8"	7/8" x 1"
1	330	625	760	830	980	1100
2	530	1010	1150	1500	1620	1880
3	665	1240	1550	1800	2240	2600
5	810	1740	2200	2940	3700	4300
8	1100	2400	3620	4480	6000	6850
10	1320	3000	4550	6000	7400	>7500
15	1660	3850	7000	>7500		
25	2200	5100	>7500			
35	2860	6650				
50	3750	>7500				
75	5450					
100	6600					

Notes:

*Individual regulator performance may vary from data shown.

 Do not operate orifice in shaded inlet pressure area.

B34S Performance Curves

14" w.c. Set Point

Type and model	B34S R
Inlet size	2" NPT
Outlet size	2" NPT
Orifice size	1/4" x 3/8"

All test results are reported at a base of 14.7 PSIA at 60° F and with 0.6 S.G. gas.

Performance Curves

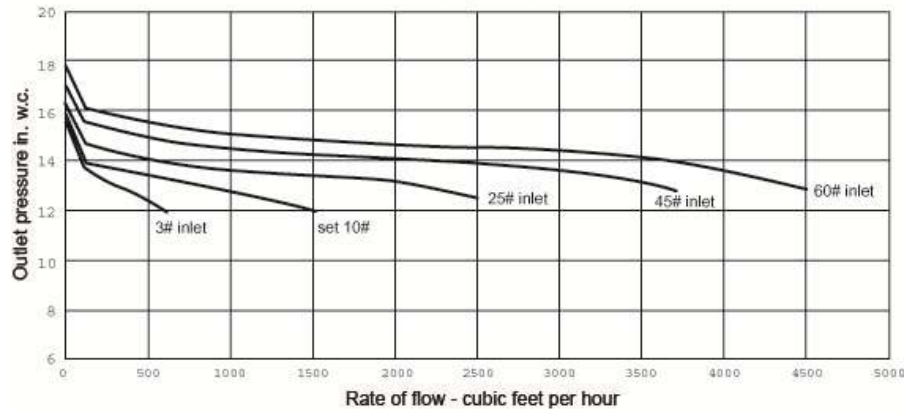

Relief Curves

14" w.c. Set Point

Inlet size	2" NPT
Outlet size	2" NPT
Vent size	1" NPT

All test results are reported at a base of 14.7 PSIA at 60° F and with 0.6 S.G. gas.

Relief Curves

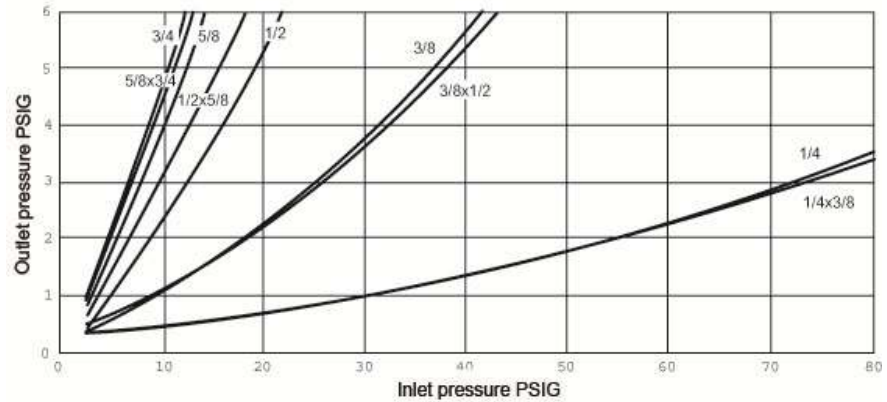

B34S SERIES COMMERCIAL REGULATOR – MODELS SN AND SR

Capacity Table 1 PSIG (1% Absolute Droop*)

Typical Capacity Info.

Manufacturer	Itron
Type and model	B34SR
Regulator	
Inlet size:	2" NPT
Outlet size:	2" NPT

Capacities in SCFH of 0.6 S.G. gas; base conditions of 14.7 PSIA and 60° F.

Inlet Pressure PSIG	Orifice Size					
	1/4" x 3/8"	3/8" x 1/2"	1/2" x 5/8"	5/8" x 3/4"	3/4" x 7/8"	7/8" x 1"
2	425	580	720	890	1000	1120
3	590	780	940	1200	1300	1540
5	800	1080	1300	1560	1840	2220
8	1000	1440	1840	2400	2800	2860
10	1130	1720	2100	2750	3640	3900
15	1470	2300	3100	4100		
25	1900	3620	5200			
35	2680	4400				
50	3700	>7500				
75	5555					
100	6050					

Capacity Table 1 PSIG (2% Absolute Droop*)

Typical Capacity Info.

Manufacturer	Itron
Type and model	B34SR
Regulator	
Inlet size:	2" NPT
Outlet size:	2" NPT

Capacities in SCFH of 0.6 S.G. gas; base conditions of 14.7 PSIA and 60° F.

Inlet Pressure PSIG	Orifice Size					
	1/4" x 3/8"	3/8" x 1/2"	1/2" x 5/8"	5/8" x 3/4"	3/4" x 7/8"	7/8" x 1"
2	560	930	1180	1460	1720	1920
3	750	1250	1600	1980	2300	2620
5	970	1800	2240	2820	3300	3800
8	1240	2400	3080	4020	4720	5150
10	1390	2840	3620	4750	5750	6500
15	1700	3520	5000	6400		
25	2300	5000	>7500			
35	2900	6150				
50	3700	>7500				
75	5555					
100	6670					

Notes:

*Individual regulator performance may vary from data shown.

Do not operate orifice in shaded inlet pressure area.

B42S Performance Curves

1 PSIG Set Point

Type and model	B34S R
Inlet size	2" NPT
Outlet size	2" NPT
Orifice size	1/4" x 3/8"

All test results are reported at a base of 14.7 PSIA at 60° F and with 0.6 S.G. gas.

Performance Curves

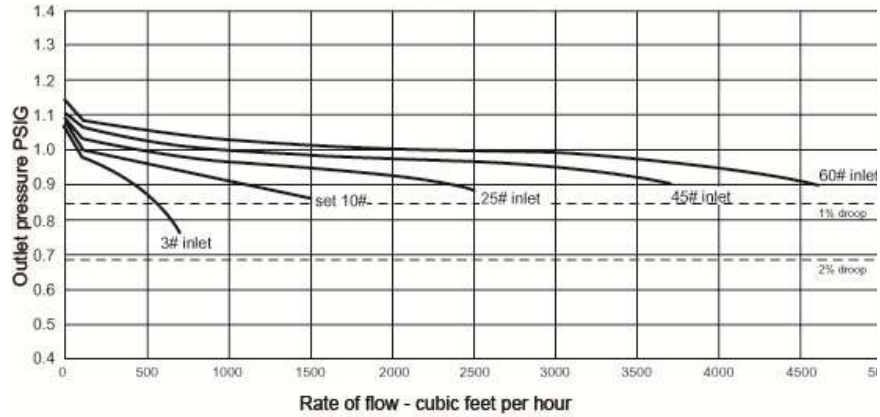

B42S Relief Curves

1 PSIG Set Point

Inlet size	2" NPT
Outlet size	2" NPT
Vent size	1" NPT

All test results are reported at a base of 14.7 PSIA at 60° F and with 0.6 S.G. gas.

Relief Curves

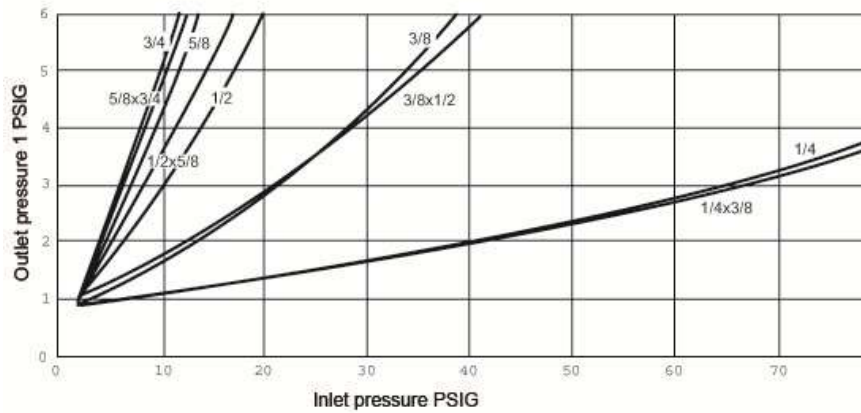

B34S SERIES COMMERCIAL REGULATOR – MODELS SN AND SR

Capacity Table 2 PSIG (1% Absolute Droop*)

Typical Capacity Info.

Manufacturer	Itron
Type and model	B34SR
Regulator	
Inlet size:	2" NPT
Outlet size:	2" NPT

Capacities in SCFH of 0.6 S.G. gas; base conditions of 14.7 PSIA and 60° F.

Inlet Pressure PSIG	Orifice Size					
	1/4" x 3/8"	3/8" x 1/2"	1/2" x 5/8"	5/8" x 3/4"	3/4" x 7/8"	7/8" x 1"
3	305	490	510	600	650	770
5	445	700	760	860	1030	1170
8	520	890	965	1290	1500	1780
10	560	990	1220	1420	1740	2040
15	750	1240	1310	1780		
25	975	1850	2100			
35	1200	2060				
50	1500	3550				
75	2130					
100	2730					

Capacity Table 2 PSIG (2% Absolute Droop*)

Typical Capacity Info.

Manufacturer	Itron
Type and model	B34SR
Regulator	
Inlet size:	2" NPT
Outlet size:	2" NPT

Capacities in SCFH of 0.6 S.G. gas; base conditions of 14.7 PSIA and 60° F.

Inlet Pressure PSIG	Orifice Size					
	1/4" x 3/8"	3/8" x 1/2"	1/2" x 5/8"	5/8" x 3/4"	3/4" x 7/8"	7/8" x 1"
3	470	800	920	1120	1230	1480
5	775	1200	1440	1690	2100	2300
8	930	1670	1960	2450	2980	3500
10	1020	1920	2320	2760	3750	4200
15	1400	2700	2950	3780		
25	1960	3850	4950			
35	2400	4950				
50	3300	>7500				
75	4250					
100	5440					

Notes:

*Individual regulator performance may vary from data shown.

Do not operate orifice in shaded inlet pressure area.

B42S Performance Curves

2 PSIG Set Point

Type and model	B34S R
Inlet size	2" NPT
Outlet size	2" NPT
Orifice size	1/4" x 3/8"

All test results are reported at a base of 14.7 PSIA at 60° F and with 0.6 S.G. gas.

Performance Curves

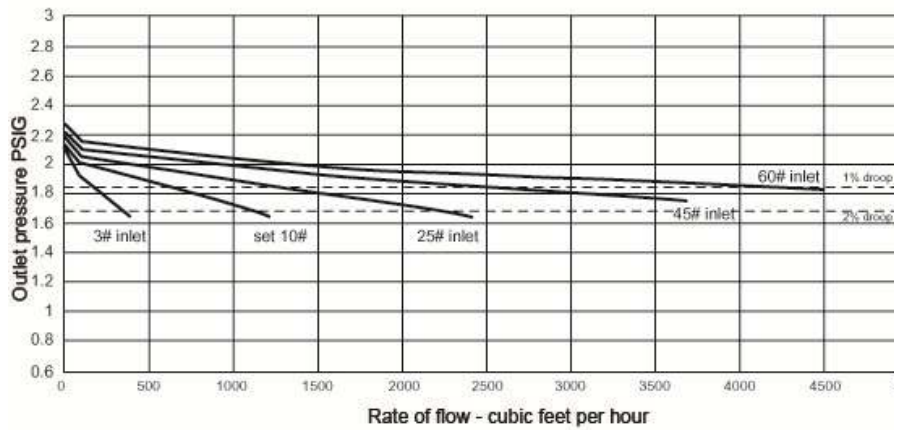

B42S Relief Curves

2 PSIG Set Point

Inlet size	2" NPT
Outlet size	2" NPT
Vent size	1" NPT

All test results are reported at a base of 14.7 PSIA at 60° F and with 0.6 S.G. gas.

Relief Curves

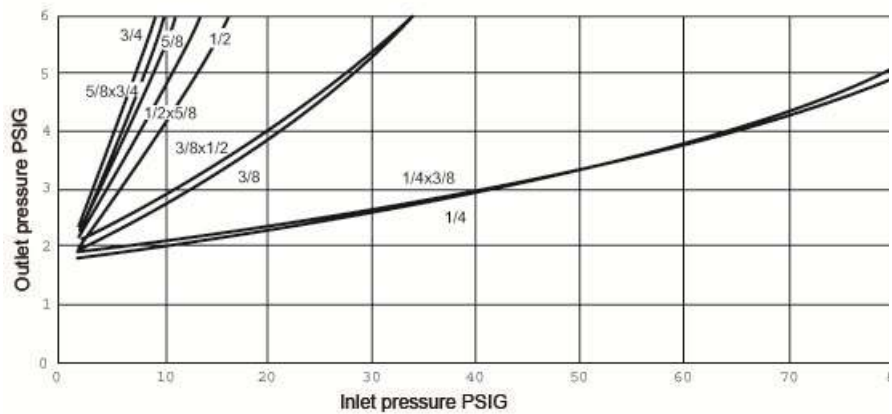

ASSEMBLY POSITIONS

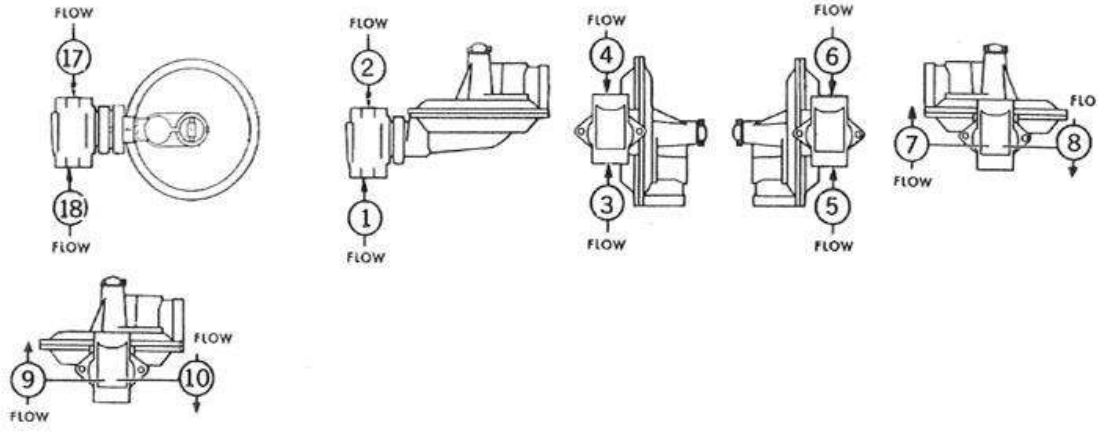

PARTS LIST

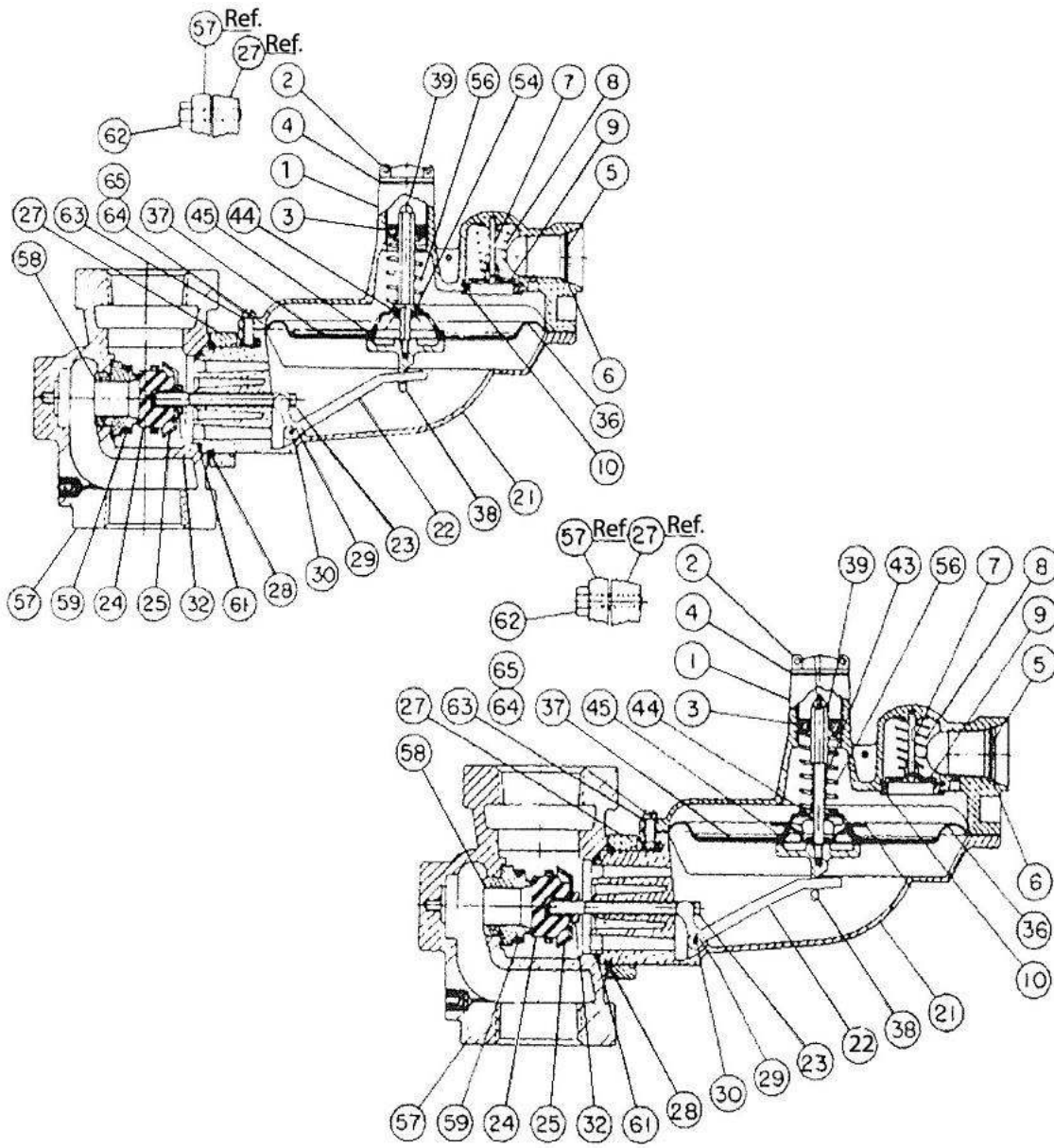

Item No.	Part No.	Qty. Required per Regulator Model				Description
		SRHP	SNHP	SR	SN	
1						Upper diaphragm case, please specify vent pipe size:
	753104			1	1	Vent - 1/4" pipe
	753107	1	1			Vent - 1/4" pipe / H.P.
	753127			1	1	Vent - 3/8" pipe
	753154			1	1	Vent 3/4" pipe (standard)
	753204			1	1	Vent 1" pipe
	753207	1	1			Vent 1" pipe / H.P.
2	760058			1	1	Seal cap - gray in. w.c.
	760059	1	1			Seal cap - PSIG
	760060			1	1	Seal cap - red in. w.c.
	760062	1	1			Seal cap - gray PSIG
3	760215			1	1	Adjustment screw - Delrin
	760217					For HP
4	765773	1	1	1	1	Seal cap gasket Note: For indoor regulator installation, use seal cap gasket, P/N (leak proof seal)
5		1	1	1	1	Vent screen, please specify:
	762935					Wire mesh for all vents except 1"
	762933					Wire mesh for 1" vent only
6		1	1	1	1	Vent screen retainer ring, please specify
	755727					For all vents except 1"
	755791					For 1" vent only
7		1	1	1	1	Vent valve disc pin, please specify:
	754806					For all vents except 1"
	754834					For 1" vent only
8	762601	1	1	1	1	Vent valve spring - 1/2 oz.
9	765181	1	1	1	1	Vent valve disc
10	765685	1	1	1	1	Vent valve seat
21	752124	1	1	1	1	Lower diaphragm case - 4:1 ratio
22	761231	1	1	1	1	Valve linkage lever - 4:1 ratio
23	754021	1	1	1	1	Valve stem - aluminum
24	765201	1	1	1	1	Valve seat - Buna "N" 75-85 Duro
25	761721	1	1	1	1	Deflector
27	751913	1	1	1	1	Valve body reference plate - aluminum
28	755725	1	1	1	1	Retainer plate snap ring
29	755141	2	2	2	2	Valve linkage pin screw
30	754831	1	1	1	1	Valve linkage pin
32	754085	1	1	1	1	Valve stem adapter

Item No.	Part No.	Qty. Required per Regulator Model				Description
		SRHP	SNHP	SR	SN	
36	766121	1	1	1	1	Diameter: .028 Nylon Fabric With Buna "N"
37	761025	1	1	1	1	Upper diaphragm plate
38	756043	1	1	1	1	Lower diaphragm plate
39	754301	1		1		Stop stem
	754303		1		1	Stop stem
43		1		1		Relief spring
	762101					7" w.c. above set
44	754905	1	1	1	1	Stop stem guide bushing
45	761661			1	1	Relief cap
	761663	1	1			Relief cap
54	755801		1		1	Diaphragm plate washer
56				1	1	Adjustment spring - specify
	762111			1	1	Brown 4.5to 5.5" W.C.
	762117			1	1	D. Green 5.0 to 7.0" W.C.
	762119			1	1	L. Green 5.5 to 8.0" W.C.
	762123			1	1	Black 7.0 to11.0 W.C.
	762127			1	1	Blue 8.0 to 12.0" W.C.
	762129			1	1	Silver 11.0 to 16.0" W.C.
	762131	1	1			Yellow 1.1 to 1.5 PSIG
	762135	1	1			Red 1.3 to 2.0 PSIG
	762137	1	1			White 1.75 to 2.5 PSIG
	762025	1	1			Red/Gray .75 to 1.1 PSIG
57		1	1	1	1	Valve body, please specify type & size
						Straight:
	750604					1-1/4 x 1-1/4 NPT
	750607					1-1/4 X 1-1/4 NPT w/1/8 NPT pipe plug
	750627					1-1/4 x 1-1/2 NPT
	750630					1-1/4 x 1-1/2 NPT with 1/8 NPT pipe plug
	750654					1-1/4 x 2 NPT
	750657					1-1/4 x 2 NPT with 1/8 NPT pipe plug
	750676					1-1/2 x 1-1/2 NPT
	750680					1-1/2 x 1-1/2 NPT with 1/8 NPT pipe plug
	750704					1-1/2 x 2 NPT
	750707					1-1/2 x 2 NPT with 1/8 NPT pipe plug
	750726					2 x 2 NPT
	750730					2 x 2 NPT with 1/8 NPT pipe plug

Item No.	Part No.	Qty. Required per Regulator Model				Description
		SRHP	SNHP	SR	SN	
Flanged:						
	750754					2" ASA
	750757					2" ASA with 1/8" NPT pipe plug
	750804					3" ASA
	750807					3" ASA with 1/8" NPT pipe plug
	750777					2" ASA short flanged - 125 lbs.
	750780					2" ASA with 1/8 NPT pipe plug short flg 125 lbs.
Orifice - straight						
	758101					1/4 diameter
	758104					3/8 diameter
	758107					1/2 diameter
	758110					5/8 diameter
	758113					3/4 diameter
	758117					7/8 diameter
Tapered - brass						
	758172					5/32" x 3/16"
	758150					7/32" x 1/4"
	758151					1/4 x 3/8 diameter
	758154					5/16 x 3/8 diameter
	758157					3/8 x 1/2 diameter
	758160					1/2 x 5/8 diameter
	758163					5/8 x 3/4 diameter
	758166					3/4 x 7/8 diameter
	758169					7/8 x 1 diameter
59	761761	1	1	1	1	Loading Ring
61	765651	1	1	1	1	Valve body gasket
62	755381	2	2	2	2	Retainer plate, screw hex head - steel
63		1	1	1	1	Curved regulator plate
	769203					As silk screened & embossed
64	755251	8	8	8	8	Case screw - Fillister head #12
65	755661	8	8	8	8	Case screw nut-square #12-24 Cad. steel

Item No.	Part No.	Description
65	799051	Spring adjustment - wrench
	799081	Loading ring - positioning tool
	799021	Thin wall orifice - socket

VENT LINES FOR REGULATORS

When constructing vent lines to be attached to regulators installed indoors, follow a few basic rules:

- a. Never use pipe sizes smaller than the vent size; smaller pipe sizes restrict the gas flow. If a long gas run must be used, Itron advises increasing the pipe one nominal size every ten feet to keep the flow restriction as low as possible.
- b. Keep the vent line length as short as possible to minimize the restriction and reduce the vent's tendency to cause regulator pulsation.
- c. Support the vent pipe to eliminate strain on the regulator diaphragm case.
- d. Always point outdoor vent pipes in the downward position to reduce the possibility of rain, snow, sleet, and other moisture entering the pipe. Install a bug screen in the end of the pipe.
- e. Do not locate the vent line terminus near windows, fans, or other ventilation equipment. See the installation instructions furnished with the regulator.
- f. Adhere to all applicable codes and regulations.
- g. If your vent pipe causes regulator pulsation, consult your sales representative or manufacturer.
- h. Itron strongly recommends running a separate vent line for each regulator. Headers with various installed devices can cause regulator malfunction.

Caution Ensure the end of the vent line is away from ANY potential ignition sources. It is the installer's responsibility to ensure the vent line is exhausting to a safe environment.

INSTALLATION

Warning Itron does not endorse or warrant the completeness or accuracy of any third party regulator installation procedures or practices, unless otherwise provided in writing by Itron. Follow your company's standard operating procedures regarding the use of personal protection equipment (PPE). Adhere to guidelines issued by your company in addition to those given in this document when installing regulators.

- a. Remove all shipping plugs from the regulator inlet, outlet, and vent before installation.
- b. Verify the piping interior and regulator inlet and outlet are clean and free of dirt, pipe dope, and other debris. Dirt and other foreign materials entering the regulator can cause a loss of pressure control.
- c. Apply pipe joint sealant to the male pipe threads. Do not use pipe joint material on the regulator's female threads. Joint sealant could become lodged in the regulator and cause a loss of pressure control.
- d. Gas must flow through the regulator's valve body in the direction cast on the regulator body. Gas flowing in the wrong direction can overpressure and cause damage to the regulator.
- e. The diaphragm casing can be mounted in any position relative to the body through a full 360° angle at 90° increments.
- f. When the regulator is installed OUTDOORS, the vent must always be positioned so that rain, snow, moisture or foreign particles cannot enter the vent opening. Itron recommends positioning the vent downward to avoid entry of water or other matter which could interfere with the proper operation of the regulator. The vent should be located away from building eaves, window openings, building air intakes and above the expected snow level at the site. Inspect the vent opening periodically to insure it does not become blocked by foreign material as outlined in DOT PHMSA-RSPA-2004-19856.
- g. When the regulator is installed INDOORS, the vent must be piped to the outside atmosphere using the shortest length of pipe, the fewest possible pipe elbows, and a pipe diameter as large as the vent size or larger. USING VENT PIPE SMALLER THAN THE VENT CONNECTION LIMITS THE REGULATOR'S INTERNAL RELIEF VALVE CAPACITY. The outlet end of the pipe must be protected from moisture and the entrance of foreign particles. The regulator should be specified by the user with the size vent and pipe threads desired to make the vent pipe connection.

SET-UP PROCEDURE

- a. Mount a pressure gauge downstream of the regulator to monitor the downstream pressure.
- b. With the downstream pressure valve closed, slowly open the inlet valve. The outlet pressure should rise to slightly more than the set-point. Verify there are no leaks and all connections are tight.
- c. The regulator was pre-set at the factory to match order specifications. If necessary, adjust the outlet pressure by removing the seal cap on the top of the spring housing and adjusting the ferrule or screw inside the pilot spring housing using a large flat-head screwdriver. With a small amount of gas flowing through the regulator, rotate the pilot ferrule clockwise to raise the outlet pressure or counter-clockwise to lower the outlet pressure.
- d. Replace the seal cap and check for leaks after the desired outlet pressure is achieved.

The regulator is ready for operation.

SAFETY WARNING

This product, as of the date of manufacture, is designed and tested to conform to all governmental and industry safety standards as they may apply to the manufacturer. The purchaser/user of this product must comply with all fire control, building codes, and other safety regulations governing the application, installation, operation, and general use of this regulator to avoid leaking gas hazards resulting from improper installation, startup or use of this product.

Itron strongly recommends installation by a qualified professional and periodic inspection of pressure regulators (inspections may be required by local applicable codes or regulations).

Inspections should include checking for gas quality, cycle numbers, external environmental changes, and operating conditions that impact wear on the regulator's moving parts. To ensure safe and efficient operation of this product, replace worn or damaged parts found during inspection.

LIMITED WARRANTY

Itron, Inc. 970 Highway 127 North, Owenton, Kentucky 40359-9302, warrants this gas product against defects in materials and workmanship for the earlier of one (1) year from the date the product is shipped by Itron or a period of one year from the date the product is installed by Itron at the original purchaser's site. During such one-year period, provided that the original purchaser continues to own the product, Itron will, at its sole option, repair any defects, replace the product or repay the purchase price.

» This warranty will be void if the purchaser fails to observe the procedures for installation, operation or service of the product as set forth in the Operating Manual and Specifications for the product or if the defect is caused by tampering, physical abuse or misuse of the product.

» ITRON SPECIFICALLY DISCLAIMS ALL IMPLIED WARRANTIES INCLUDING THOSE OF MERCHANTABILITY OR OF FITNESS FOR A PARTICULAR PURPOSE. UNDER NO CIRCUMSTANCES WILL ITRON BE LIABLE FOR INCIDENTAL OR CONSEQUENTIAL DAMAGES OF ANY KIND WHATSOEVER.

» Itron's liability for any claim of any kind, including negligence and breach of warranty for the sale and use of any product covered by or furnished, shall in no case exceed the price allocable to the product or part thereof which gives rise to the claim.

» In the event of a malfunction of the product, consult your Itron Service Representative or Itron Inc., 970 Highway 127 North, Owenton, Kentucky 40359-9302. See Itron Terms and Conditions of Sale for the full and complete terms of the Limited Warranty.

ORDERING INFORMATION

Specify:

1. Inlet and outlet connection size and type
2. Model number
3. Outlet pressure desired
4. Pilot needed
5. Inlet pressure range
6. Type of gas and maximum capacity required
7. Assembly position number (see chart above)
8. Special requirements such as tagging, 1/8" pipe plug tap, seal wire, etc.



Itron is the world's leading provider of smart metering, data collection and utility software systems, with over 8,000 utilities worldwide relying on our solutions to responsibly and efficiently manage the delivery and use of energy and water. To realize your smarter energy and water future, start here: www.itron.com

ITRON GAS

970 Highway 127 North
Owenton, Kentucky 40359
USA

Phone: 1.800.490.0657

Fax: 1.502.484.6223

CORPORATE HEADQUARTERS

2111 N Molter Road
Liberty Lake, WA 99019
USA

Phone: 1.800.635.5461

Fax: 1.509.891.3355