

Features

- Lightweight, low-cost valves for air service
- Ideal for low pressure applications
- Provides high flow, Cv up to 138 (Kv 118)
- Air and vacuum service

Construction

Valve Parts in Contact with Fluids	
Body	Aluminum
Seals, Diaphragms, Disc	NBR
Disc-Holder	PA (10.1 and 11.6 watt Normally Open only)
Core Guide	POM
Core Tube	305 Stainless Steel
Rider Rings	PTFE
Core and Plugnut	430F Stainless Steel
Springs*	302 Stainless Steel
Shading Coil	Copper

* For 8040H006, 8040H007, 8040H008, spring material is 17-7 PH

Electrical

Standard Coil and Class of Insulation	Watt Rating and Power Consumption				Spare Coil Part No.			
	DC Watts	AC			General Purpose		Explosionproof	
		Watts	VA Holding	VA Inrush	AC	DC	AC	DC
F	-	6.1	16	40	238210	-	238214	-
F	11.6	10.1	25	70	238610	238710	238614	238714
F	15.8	15.4	27	160	99257	501695	99257	501696
F	-	28.2	50	385	206409	-	206409	-

Standard Voltages: 24, 120, 240, 480 volts AC, 60 Hz (or 110, 220 volts AC, 50 Hz), 6, 12, 24, 120, 240 volts DC. Must be specified when ordering. Other voltages available when required. (Note: 24 volt AC, 60 Hz not available with 28.2 watt coil)

Solenoid Enclosures

Standard: RedHat II - Watertight, Types 1, 2, 3, 3S, 4, and 4X; RedHat - Type I.

Optional: RedHat II - Explosionproof and Watertight, Types 3, 3S, 4, 4X, 6, 6P, 7, and 9; RedHat - Explosionproof and Raintight, Types 3, 7, and 9. (Except EF8215A40 and EF8215A90, which are suitable for Types 3 and 7 (C and D) only and have a T2B temperature rating code.)

To order, add prefix "EF" to catalog number.

See *Optional Features Section* for other available options.

Nominal Ambient Temp. Ranges

Series	AC	DC
	RedHat II/RedHat	RedHat II
8040	-40°F to 125°F (-40°C to 52°C)	-
8215	32°F to 125°F (0°C to 52°C)	32°F to 104°F (0°C to 40°C)

Refer to Engineering Section for details.

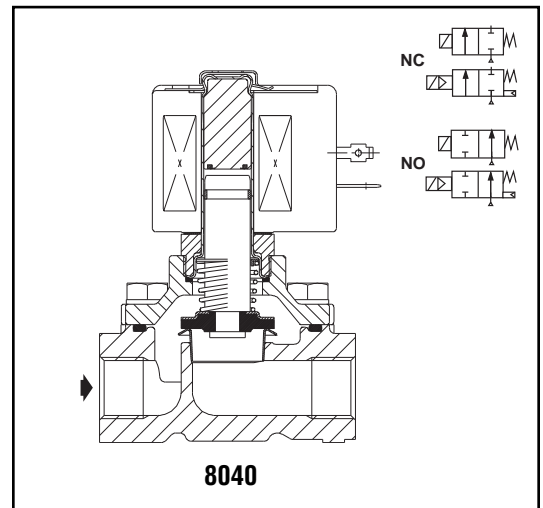

Approvals:

CSA certified to:

8040 Series:

- 1) Standard C22.2 No. 139 "Electrically Operated Valves," File 10381.
- 2) Automatic Gas Valves Z21.21 (6.5) C/I, File 112872.
- 3) Automatic Gas Safety Shutoff Valves (3.9), File 112872.

8215 Series Normally Closed:

- 1) Standard C22.2 No. 139 "Electrically Operated Valves," File 10381.
- 2) Automatic Gas Valves Z21.21 (6.5) C/I, File 112872.

8215 Series Normally Open:

- 1) Standard C22.2 No. 139 "Electrically Operated Valves," File 10381.

UL listed, as indicated. FM approved (Normally Closed only, except Catalog Numbers 8215A090 and 8215A040). RedHat II meets applicable CE directives.

Refer to Engineering Section for details.

Specifications (English units)

Pipe Size (in)	Orifice Size (in)	Cv Flow Factor	Gas Capacity Btu/hr ⑥	Operating Pressure Differential (psi)			Max. Fluid Temp. °F		Aluminum Body Catalog Number	Const. Ref.		UL ⑤ Listing	Watt Rating/ Class of Coil Insulation ②	
				Min.	Max. AC	Max. DC	AC	DC		AC	DC		AC	DC
					Air-Fuel Gas	Air-Fuel Gas								
NORMALLY CLOSED (Closed when de-energized)														
1/8	5/16	1.0	53,700	0	15	-	125	-	8040H006	11	○	6.1/F	-	
1/4	5/16	1.1	59,000	0	15	-	125	-	8040H007	11	○	6.1/F	-	
3/8	5/16	1.2	64,400	0	15	-	125	-	8040H008	11	○	6.1/F	-	
3/8	3/4	3.4	183,000	0	50	25	125	104	8215G010	2	○	10.1/F	11.6/F	
3/8	3/4	3.5	-	5	125	125	125	104	8215G001 ①	1	○	6.1/F	11.6/F	
1/2	3/4	5.4	291,000	0	2	-	125	-	8040G022	13A	○	10.1/F	-	
1/2	3/4	4.4	238,500	0	50	25	125	104	8215G020	2	○	10.1/F	11.6/F	
1/2	3/4	4.8	-	5	125	125	125	104	8215G002 ①	1	○	6.1/F	11.6/F	
3/4	3/4	9.5	512,000	0	2	-	125	-	8040G023	13B	○	10.1/F	-	
3/4	3/4	5.1	247,500	0	50	25	125	104	8215G030	4	○	10.1/F	11.6/F	
3/4	3/4	5.1	-	5	125	125	125	104	8215G003 ①	3	○	6.1/F	11.6/F	
1	1 5/8	21	1,119,000	0	25	-	125	-	8215B050 ③	6	○	15.4/F	-	
1	1 5/8	21	1,119,000	0	-	25	-	104	8215G050 ③⑧⑨	16	○	-	15.8/F	
1 1/4	1 5/8	32	1,730,000	0	25	-	125	-	8215B060 ③	6	○	15.4/F	-	
1 1/4	1 5/8	32	1,730,000	0	-	25	-	104	8215G060 ③⑧⑨	16	○	-	15.8/F	
1 1/2	1 5/8	35	1,900,000	0	25	-	125	-	8215B070 ③	6	○	15.4/F	-	
1 1/2	1 5/8	35	1,900,000	0	-	25	-	104	8215G070 ③⑧⑨	16	○	-	15.8/F	
2	2 3/32	60	3,251,000	0	25	-	125	-	8215B080 ③	7	○	15.4/F	-	
2	2 3/32	60	3,251,000	0	-	15	-	104	8215G080 ③⑧⑨	17	○	-	15.8/F	
2 1/2	3	117	5,821,000	0	5	-	125	-	8215A090 ⑦	8	○	28.2/F	-	
3	3	138	7,430,000	0	5	-	125	-	8215A040 ⑦	8	○	28.2/F	-	
NORMALLY OPEN (Open when de-energized)														
3/8	3/4	3.2	172,500	0	125	125	125	104	8215G013	9	●	10.1/F	11.6/F	
1/2	3/4	4	206,250	0	125	125	125	104	8215G023	9	●	10.1/F	11.6/F	
3/4	3/4	4.6	247,500	0	125	125	125	104	8215G033	10	●	10.1/F	11.6/F	
1	1 5/8	22	1,191,750	0	25	15	125	104	8215C053	12	-	●	15.4/F	
1	1 5/8	22	1,191,750	0	25	15	125	104	8215G053 ⑧⑨	-	18	●	-	
1 1/4	1 5/8	33	1,793,250	0	25	15	125	104	8215C063	12	-	●	15.4/F	
1 1/4	1 5/8	33	1,793,250	0	25	15	125	104	8215G063 ⑧⑨	-	18	●	-	
1 1/2	1 5/8	37	1,988,250	0	25	15	125	104	8215C073	13	-	●	15.4/F	
1 1/2	1 5/8	37	1,988,250	0	25	15	125	104	8215G073 ⑧⑨	-	18	●	-	
2	2 3/32	58	3,100,000	0	25	15	125	104	8215C083	14	-	●	15.4/F	
2	2 3/32	58	3,100,000	0	25	15	125	104	8215G083 ⑧⑨	-	19	●	-	
2 1/2	3	117	6,290,000	0	5	-	125	-	8215B093 ④⑦	15	●	28.2/F	-	

① Do not use for Fuel Gas.

② On 50 hertz service, the watt rating for the 6.1/F solenoid is 8.1 watts.

③ FM Approved Process Control Valves. See Engineering Section (Approvals) for details.

④ Type I enclosure only.

⑤ ○ = Safety Shutoff Valve; ● = General Purpose Valve. Refer to Engineering Section (Approvals) for details.

⑥ 1" W.C. Drop @ 2" W.C. Inlet Pressure, 1,000 Btu/cu.ft. or more, 0.64 Specific Gravity Gas.

⑦ Not available with 24 volt, 60 Hz coil.

⑧ Coil options EF, HT, and HC only.

⑨ Not available with 6 VDC coil.

Specifications (Metric units)

Pipe Size (in)	Orifice Size (mm)	Kv Flow Factor (m3/h)	Gas Capacity Btu/hr ⑥	Operating Pressure Differential (bar)			Max. Fluid Temp. °C		Aluminum Body Catalog Number	Const. Ref.		UL ⑤ Listing	Watt Rating/Class of Coil Insulation ②	
				Min.	Max. AC	Max. DC	AC	DC		AC	DC		AC	DC
					Air-Fuel Gas	Air-Fuel Gas								
NORMALLY CLOSED (Closed when de-energized)														
1/8	7.9	.86	53,700	0	1.0	-	52	-	8040H006	11	○	6.1/F	-	
1/4	7.9	.94	59,000	0	1.0	-	52	-	8040H007	11	○	6.1/F	-	
3/8	7.9	1.0	64,400	0	1.0	-	52	-	8040H008	11	○	6.1/F	-	
3/8	19	2.9	183,000	0	3.4	1.7	52	40	8215G010	2	○	10.1/F	11.6/F	
3/8	19	3.0	-	0.3	8.6	8.6	52	40	8215G001 ①	1	○	6.1/F	11.6/F	
1/2	19	4.6	291,000	0	0.1	-	52	-	8040G022	13A	○	10.1/F	-	
1/2	19	3.8	238,500	0	3.4	1.7	52	40	8215G020	2	○	10.1/F	11.6/F	
1/2	19	4.1	-	0.3	8.6	8.6	52	40	8215G002 ①	1	○	6.1/F	11.6/F	
3/4	19	8.1	449,000	0	0.1	-	52	-	8040G023	13B	○	10.1/F	-	
3/4	19	4.4	247,500	0	3.4	1.7	52	40	8215G030	4	○	10.1/F	11.6/F	
3/4	19	4.4	-	0.3	8.6	8.6	52	40	8215G003 ①	3	○	6.1/F	11.6/F	
1	41	18	1,119,000	0	1.7	-	52	-	8215B050 ③	6	○	15.4/F	-	
1	41	18	1,119,000	0	-	1.7	-	40	8215G050 ③⑧⑨	16	○	-	15.8/F	
1 1/4	41	27	1,730,000	0	1.7	-	52	-	8215B060 ③	6	○	15.4/F	-	
1 1/4	41	27	1,730,000	0	-	1.7	-	40	8215G060 ③⑧⑨	16	○	-	15.8/F	
1 1/2	41	30	1,900,000	0	1.7	-	52	-	8215B070 ③	6	○	15.4/F	-	
1 1/2	41	30	1,900,000	0	-	1.7	-	40	8215G070 ③⑧⑨	16	○	-	15.8/F	
2	53	51	3,251,000	0	1.7	-	52	-	8215B080 ③	7	○	15.4/F	-	
2	53	51	3,251,000	0	-	1.0	-	40	8215G080 ③⑧⑨	17	○	-	15.8/F	
2 1/2	76	100	5,821,000	0	0.3	-	52	-	8215A090 ⑦	8	○	28.2/F	-	
3	76	118	7,430,000	0	0.3	-	52	-	8215A040 ⑦	8	○	28.2/F	-	
NORMALLY OPEN (Open when de-energized)														
3/8	19	2.74	172,500	0	8.6	8.6	52	40	8215G013	9	●	10.1/F	11.6/F	
1/2	19	3.4	206,250	0	8.6	8.6	52	40	8215G023	9	●	10.1/F	11.6/F	
3/4	19	3.9	247,500	0	8.6	8.6	52	40	8215G033	10	●	10.1/F	11.6/F	
1	41	19	1,191,750	0	1.7	1.0	52	40	8215C053	12	-	●	15.4/F	
1	41	19	1,191,750	0	1.7	1.0	52	40	8215G053 ⑧⑨	-	18	●	-	
1 1/4	41	28	1,793,250	0	1.7	1.0	52	40	8215C063	12	-	●	15.4/F	
1 1/4	41	28	1,793,250	0	1.7	1.0	52	40	8215G063 ⑧⑨	-	18	●	-	
1 1/2	41	32	1,988,250	0	1.7	1.0	52	40	8215C073	13	-	●	15.4/F	
1 1/2	41	32	1,988,250	0	1.7	1.0	52	40	8215G073 ⑧⑨	-	18	●	-	
2	53	50	3,100,000	0	1.7	1.0	52	40	8215C083	14	-	●	15.4/F	
2	53	50	3,100,000	0	1.7	1.0	52	40	8215G083 ⑧⑨	-	19	●	-	
2 1/2	76	100	6,290,000	0	0.3	-	52	-	8215B093 ④⑦	15	●	28.2/F	-	

① Do not use for Fuel Gas.

② On 50 hertz service, the watt rating for the 6.1/F solenoid is 8.1 watts.

③ FM Approved Process Control Valves. See Engineering Section (Approvals) for details.

④ Type 1 enclosure only.

⑤ ○ = Safety Shutoff Valve; ● = General Purpose Valve. Refer to Engineering Section (Approvals) for details.

⑥ 1" W.C. Drop @ 2" W.C. Inlet Pressure, 1,000 Btu/cu.ft. or more, 0.64 Specific Gravity Gas.

⑦ Not available with 24 volt, 60 Hz coil.

⑧ Coil options EF, HT, and HC only.

⑨ Not available with 6 VDC coil.

Dimensions: inches (mm)

Const. Ref.		H	K	L	P	W
1	in	3.42	2.00	2.75	2.87	2.46
	mm	87	51	70	73	63
2	ins	4.02	2.49	2.75	3.46	2.46
	mm	102	63	70	88	63
3	in	3.87	2.19	3.31	3.05	2.33
	mm	98	56	84	77	59
4	in	4.46	2.68	3.31	3.64	2.33
	mm	113	68	84	92	59
6 ①	in	6.84	4.25	5.00	5.59	5.38
	mm	174	108	127	142	137
7 ①	in	7.47	4.53	6.09	5.94	6.31
	mm	190	115	155	151	160
8 ①	in	10.25	5.75	7.79	7.91	7.94
	mm	260	146	198	201	202
9	in	4.42	2.72	2.75	3.86	2.36
	mm	112	69	70	98	60
10	in	4.86	2.72	3.31	4.04	2.36
	mm	123	69	84	103	60
11	in	2.74	1.44	2.00	2.30	1.69
	mm	69	36	51	58	43
12	in	6.84	2.22	5.00	3.63	5.38
	mm	174	56	127	92	137
13	in	6.84	2.16	5.00	3.56	5.38
	mm	174	55	127	90	137
13A	in	4.05	2.46	2.75	3.44	2.42
	mm	103	63	70	87	62
13B	in	4.49	2.65	3.31	3.63	2.39
	mm	114	67	84	92	61
14 ②	in	7.44	2.41	6.09	3.81	6.31
	mm	189	61	155	97	160
15 ②	in	10.25	3.07	7.80	5.22	7.94
	mm	260	78	198	133	202
16	in	6.7	4.4	5.00	5.5	5.38
	mm	171	111	127	139	137
17	in	7.3	4.7	6.1	5.8	6.31
	mm	186	120	155	148	160
18 ②	in	6.7	2.4	4.8	3.5	5.4
	mm	171	60	121	89	137
19 ②	in	7.3	2.6	6.1	3.7	6.3
	mm	187	66	155	95	161

IMPORTANT: Valves may be mounted in any position except all DC constructions and those marked ①, which must be mounted with the solenoid vertical and upright. Constructions marked ② must be mounted with the solenoid vertical and upright or horizontal only.

Const. Ref. 1-4, 9, 10, 13A, 13B

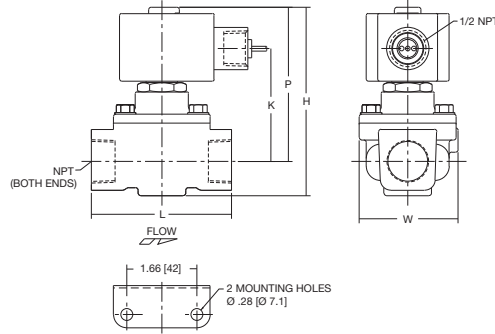

Const. Ref. 6, 7, 8

Const. Ref. 16, 17

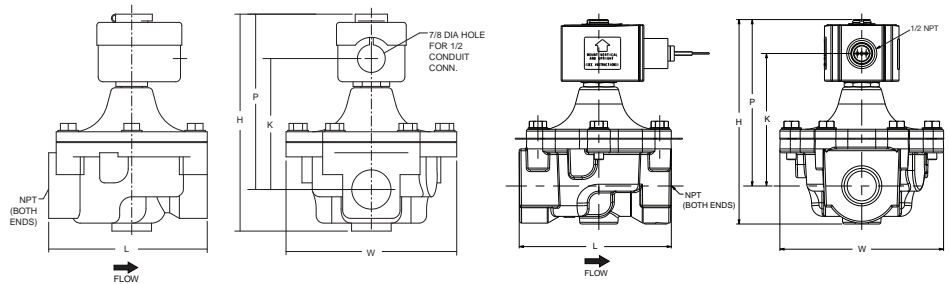

Const. Ref. 11

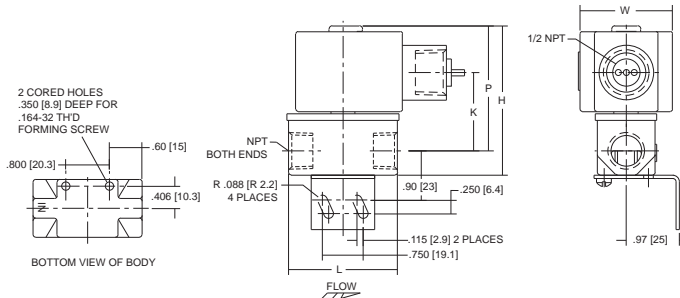

Const. Ref. 12-15

Const. Ref. 18-19

