

P627 High Flow Gas Regulator



- Wide Range of Flow Capacities
- Durable Powder Coated Exterior
- Installation Versatility
- NACE Construction Available

The P627 is a spring loaded, direct-operated regulator for both low and high pressure applications in the oil and gas industries. These regulators provide durability, from the powder-coated epoxy exterior finish, as well as installation versatility, from the multi-position body and spring case configurations. These regulators are also available in an external pressure registration model (P627M), and NACE construction.

Applications

- Farm Tap Regulation
- Monitoring Regulators
- Gate Regulators
- Fuel Gas
- Gas Gathering
- Pressure Reduction



Authorized Distributor:
Linc Energy Systems
LincEnergySystems.com

Materials of Construction

Body, Bonnet, Diaphragm Case	
Options	Steel Body, Bonnet & Diaphragm Case
	Cast Ductile Iron Body / Aluminum Bonnet & Diaphragm Case
	Steel Body / Aluminum Bonnet & Diaphragm Case (NACE only)
	Steel Casing / LCC Body
	Aluminum Casing / LCC Body
	CF8M SS Body, Bonnet & Diaphragm Case
Diaphragm	
Option	Nitrile (low pressure) or Neoprene (high pressure)
Seat	
Options	Nitrile
	Nylon
	Fluorocarbon
Orifice	
Options	Aluminum
	Stainless Steel (NACE only)

Specifications

Maximum Inlet Body Pressure		
Nylon Seat	2000 PSIG	Steel / SS
	1000 PSIG	Ductile Iron
	1485 PSIG	Flanged Steel
Nitrile Seat	1000 PSIG	All Units
Fluorocarbon Seat	300 PSIG	All Units
Outlet		
	5–500 PSIG	
Body Sizes		
	3/4 NPT	
	1 NPT	
	2 NPT	
Orifice Sizes		
	3/32"	
	1/8"	
	3/16"	
	1/4"	
	3/8"	
	1/2"	
Output		
	Outlet Range	Flow Range*
	5–20 PSIG	300–43,000
	15–40 PSIG	1,000–71,000
	35–80 PSIG	1,200–142,000
	10–95 PSIG	1,000–150,000
	70–150 PSIG	2,500–172,000
	140–250 PSIG	3,200–95,000
	240–500 PSIG	4,500–140,000
	* (SCFH of 0.6 S.G. Natural Gas)	
Temperature Range		
Steel, Iron Body	–20° to 180° F	(–29° to 82° C)
CF8M Body	–40° to 180° F	(–40° to 82° C)
Weight Approximate		
1"	5.3 lbs	2.39 kg
2"	8.8 lbs	3.96 kg

Maximum Bonnet and Diaphragm Casing Pressure	Spring & Diaphragm Casing Style	P627		P627M		P627H & P627HM	
		PSIG	BAR	PSIG	BAR	PSIG	BAR
Maximum pressure to spring and diaphragm casing to prevent leak to atmosphere (internal parts damage may occur).	Die Cast Aluminum	250	17.2	250	250	N/A	N/A
	Steel / SS	250	17.2	250	17.2	800	55.2
Maximum pressure to spring and diaphragm casings to prevent burst of casings during abnormal operation (leak to atmosphere and internal parts may occur).	Die Cast Aluminum	375	25.9	375	375	N/A	N/A
	Steel / SS	1200	82.7	1200	82.7	1200	82.7
Maximum diaphragm casing overpressure to prevent damage to internal parts.	All	60	4.1	60	4.1	120	8.3

P627 Regulator Rebuild Kits

	Kit Includes	Part Number
P627 Low Pressure	Nitrile diaphragms (2), Nitrile valve disk, O-rings, back-up rings, and retaining pin	971-627-000
	Nitrile diaphragms (2), Nylon valve disk, O-rings, back-up rings, and retaining pin.	971-627-001
P627 High Pressure	Neoprene diaphragm, Nitrile valve disk, O-rings, back-up rings, and retaining pin	971-627-002
	Neoprene diaphragm, Nylon valve disk, O-rings, back-up rings, and retaining pin	971-627-003

	Kit Includes	Part Number
P627 Low Pressure NACE	Nitrile diaphragms (2), SS Nitrile valve disk, O-rings, back-up rings, and retaining pin	971-627-N00
	Nitrile diaphragms (2), SS Nylon valve disk, O-rings, back-up rings, and retaining pin	971-627-N01
P627 High Pressure NACE	Neoprene diaphragm, SS Nitrile valve disk, O-rings, back-up rings, and retaining pin	971-627-N02
	Neoprene diaphragm, SS Nylon valve disk, O-rings, back-up rings, and retaining pin	971-627-N03

P627 Part Matrix

P627							1	
	↑	↑	↑	↑	↑	↑	↑	Port Size
06								3/4"
08								1"
16								2"
								Spring Range
								PSIG BAR
020								5 - 20 0.34 - 1.4
040								15 - 40 1 - 2.8
080								35 - 80 2.4 - 5.5
095								10 - 95 0.7 - 6.6
150								70 - 150 4.8 - 10.3
250								140 - 250 9.7 - 17.2
500								240 - 500 16.5 - 34.5
								Special Adders
0								None
2								Monitor
A								150 #RF*
B								300 #RF*
C								600 #RF*
D								Socket Weld*
E								900 #RTJ*
W								150 #RF & Monitor*
X								300 #RF & Monitor*
Y								600 #RF & Monitor*
Z								Socket Weld & Monitor*
								Versions
0								Standard
N								NACE
F								NACE & Fluorocarbon Elastomers
T								Stainless Trim
								Orifice
0								3/32"
2								1/8"
3								3/16"
4								1/4"
6								3/8"
8								1/2"
								Seat Material
0								Nitrile
1								Nylon
2								Fluorocarbon
1								
								Case / Body
0								Aluminum / Iron
1								Steel / Steel
2								Aluminum / Steel
6								Aluminum / LCC Steel
7								Steel / LCC Steel
8								Steel / Iron
9								Stainless / Stainless

NOTE: Nitrile or FKM is recommended for 5-20, 15-40 and 10-95 PSIG. Nylon is recommended for pressures above 150 PSIG or low pressure 3/32" & 1/8" orifice.

*Steel, LCC Steel or Stainless Steel Bodies Only

NOTE: Nitrile or FKM is recommended for 5-20, 15-40 and 10-95 PSIG. Nylon is recommended for pressures above 150 PSIG or low pressure 3/32" & 1/8" orifice.

P627 Flow Capacities of Natural Gas (0.6 S.G.) in SCFH¹



Outlet Pressure Range	Outlet Pressure Setting		Inlet Pressure		3/4" Body Size						1" Body Size					
	PSIG	BAR	PSIG	BAR	Port Diameter, inches						Port Diameter, inches					
					3/32	1/8	3/16	1/4	3/8	1/2	3/32	1/8	3/16	1/4	3/8	1/2
5 to 20 PSIG ² (0.34 to 1.4 BAR)	5 ³	0.34	10	0.69	170	320	700	1060	1540	1900	170	330	710	1100	1900	2500
			15	1.0	240	330	810	1300	2150	3350	240	390	890	1600	2500	3350
			20	1.4	290	460	1140	1800	3050	4350	290	500	1160	2060	3400	4450
			30	2.1	380	610	1530	2490	3880	6850	380	670	1560	2800	4750	6900
			60	4.1	640	1170	2550	4240	6270	7370	640	1170	2600	4710	8140	13,700
			75	5.2	770	1410	3020	5100	6620	7700	770	1410	3150	5710	9790	14,500
	10	0.69	100	6.9	990	1800	3800	5980	7440	7900	990	1800	4070	7310	12,500	16,000
			15	1.03	210	320	800	1290	2100	3300	210	375	880	1590	2480	3300
			20	1.4	280	455	1130	1790	3000	4300	280	490	1150	2050	3380	4410
			30	2.1	380	610	1530	2480	3860	6830	380	670	1560	2800	4720	6840
			60	4.1	640	1170	2550	4240	6270	7370	640	1170	2600	4710	8140	13,700
			75	5.2	770	1410	3020	5100	6620	7700	770	1410	3150	5710	9790	14,500
			100	6.9	990	1800	3800	5980	7440	7900	990	1800	4070	7310	12,500	16,000
			150	10.3	1420	2580	5700	7130	8180	8200	1420	2580	5850	10,500	17,000	18,000
			200	13.8	1850	3370	6970	7250	8200	8300	1850	3370	7630	13,700	18,000	18,500
			300	20.7	2700	4910	8000	8050	8250		2700	4910	11,200	19,800	20,000	
			500	34.5	4010	8090	8060	8100			4400	8090	15,700	20,000		
			750	51.7	4400	8930	8950				5400	12,000	18,000			
			1000	69.0	4450	10,300					5800	14,000				
			1250	86.2	4540						6300					
	1500	103	4880						6600							
	1750	121	5230						6800							
	2000	138	5900						7600							
	20	1.4	30	2.1	350	620	1400	2490	4360	6290	350	620	1450	2580	4360	6290
			50	3.4	550	1000	2280	4010	7870	8500	550	1000	2280	4090	7870	14,100
			60	4.1	640	1170	2640	4680	8340	8940	640	1170	2640	4750	9690	14,500
			100	6.9	990	1800	3980	7220	11,500	12,600	990	1800	4070	7310	13,900	23,300
			150	10.3	1420	2580	5850	10,400	12,100	13,100	1420	2580	5850	10,500	17,700	34,200
			200	13.8	1850	3370	7340	12,000	13,200	13,700	1850	3370	7630	13,700	26,600	39,100
			300	20.7	2700	4910	11,200	13,000	15,600		2700	4910	11,200	20,100	37,000	
			500	34.5	4400	8090	18,300	15,100			4400	8090	18,300	32,900		
			750	51.7	6600	12,000	14,200				6600	12,000	23,600			
			1000	69.0	7300	14,600					8900	16,000				
			1250	86.2	7500						10,000					
			1500	103	7800						10,400					
			1750	121	8400						12,000					
2000			138	8600						14,000						
15 to 40 PSIG (1.0 to 2.8 BAR)	40	2.8	60	4.1	610	1090	2530	4350	8140	9420	610	1090	2530	4510	9290	9420
			75	5.2	760	1370	3080	5510	10,300	13,600	760	1370	3080	5640	10,800	16,500
			100	6.9	990	1790	4070	7220	13,200	15,300	990	1790	4070	7310	14,700	21,900
			150	10.3	1420	2580	5850	10,400	17,400	18,200	1420	2580	5850	10,500	20,500	34,500
			200	13.8	1850	3370	7630	13,500	18,000	18,500	1850	3370	7630	13,700	27,100	46,400
			300	20.7	2700	4910	11,200	18,500	20,000	20,700	2700	4910	11,200	20,100	40,100	67,100
			500	34.5	4400	8090	18,300	24,000	27,000		4400	8090	18,300	32,900	63,900	
			750	51.7	6600	12,000	23,000	24,200			6600	12,000	27,200	39,400		
			1000	69.0	8700	16,000	24,400				8700	16,000	36,100			
			1250	86.2	11,000	18,000					11,000	19,000				
			1500	103	12,000	21,000					13,000	22,000				
			1750	121	13,000						15,000					
			2000	138	14,000						17,000					
			35 to 80 PSIG (2.4 to 5.5 BAR)	60	4.1	75	5.2	700	1230	2760	4750	8620	15,200	700	1230	2760
100	6.9	970				1740	4010	6990	12,800	17,300	970	1740	4010	7000	13,000	19,300
150	10.3	1420				2580	5850	10,300	18,600	23,000	1420	2580	5850	10,500	18,900	32,800
200	13.8	1850				3370	7630	13,500	21,600	27,400	1850	3370	7630	13,700	24,000	42,200
300	20.7	2700				4910	11,200	19,800	26,100	30,100	2700	4910	11,200	20,100	32,500	69,100
500	34.5	4400				8090	18,300	28,100	28,900	33,400	4400	8090	18,300	32,900	64,000	94,300
750	51.8	6600				12,000	26,300	30,000	37,000	45,000	6600	12,000	27,200	43,380	66,000	130,000
1000	69.0	8700				16,000	30,000	31,200	37,400		8700	16,000	36,100	50,300	67,700	
1250	86.2	11,000				19,000	31,600	34,000			11,000	19,000	45,000	57,000		
1500	103	13,000				22,000	30,400	36,000			13,000	22,000	54,000	63,000		
1750	121	15,000		25,000	34,000				15,000	25,000	63,000					
2000	138	17,000		28,000					17,000	28,000						
80	5.5	100		5.2	900	1600	3750	6490	12,200	17,300	900	1600	3750	6650	12,200	18,600
		150		10.3	1410	2580	5850	10,200	19,600	25,700	1410	2580	5850	10,500	21,100	33,600
		200		13.8	1850	3370	7630	13,500	25,400	29,300	1850	3370	7630	13,700	28,400	44,100
		300		20.7	2700	4910	11,200	19,800	32,700	33,500	2700	4910	11,200	20,100	43,300	75,400
		500		34.5	4400	8090	18,300	31,900	36,000	36,700	4400	8090	18,300	32,900	71,600	110,000
		750		51.8	6600	12,000	27,200	35,000	44,000	46,000	6600	12,000	27,200	48,900	105,500	135,000
		1000		69.0	8700	16,000	36,100	38,000	56,200		8700	16,000	36,100	64,900	118,000	
		1250		86.2	11,000	19,000	37,000	40,000			11,000	19,000	45,000	80,000		
		1500	103	13,000	22,000	38,000	44,000			13,000	22,000	54,000	96,000			
		1750	121	15,000	25,000	42,000				15,000	25,000	63,000				
2000	138	17,000	28,000					17,000	28,000							

1. Capacity is based on 20 percent droop unless otherwise noted below.
 2. For pressure setting under 10 PSIG (0.69 BAR) limit the input pressure to 100 PSIG (6.9 BAR) to obtain the setpoint.
 3. For 5 PSIG (0.34 BAR) pressure set point, the droop is 2 PSIG (0.14 BAR)

P627 Flow Capacities of Natural Gas (0.6 S.G.) in SCFH¹

Outlet Pressure Range	Outlet Pressure Setting		Inlet Pressure		3/4" Body Size						1" Body Size					
	PSIG	BAR	PSIG	BAR	Port Diameter, inches						Port Diameter, inches					
					3/32	1/8	3/16	1/4	3/8	1/2	3/32	1/8	3/16	1/4	3/8	1/2
70 to 150 PSIG (4.8 to 10.3 BAR)	100	6.9	150	10.3	1170	2510	5540	8710	16,000	20,300	1170	2510	5540	8710	16,000	24,000
			200	13.8	1850	3370	7630	12,000	21,300	25,700	1850	3370	7630	12,000	21,300	34,100
			300	20.7	2700	4910	11,200	19,400	30,000	31,700	2700	4910	11,200	19,400	30,100	53,200
			500	34.5	4400	8090	18,300	31,800	39,000	39,200	4400	8090	18,300	31,800	66,500	83,900
			750	51.8	6600	12,000	27,200	39,000	39,200	45,900	6600	12,000	27,200	47,300	95,300	117,000
			1000	69.0	8700	16,000	36,100	40,000	40,500	47,000	8700	16,000	36,100	59,700	100,000	120,000
			1250	86.2	11,000	19,000	39,000	40,500	41,000		11,000	19,000	45,000	72,000	114,000	
			1500	103	13,000	22,000	43,000	44,000			13,000	22,000	54,000	86,000		
			1750	121	15,000	25,000	45,000	47,000			15,000	25,000	63,000	95,000		
	2000	138	17,000	28,000	46,000				17,000	28,000	71,000					
	125	8.6	150	10.3	1250	2340	5340	9130	15,700	20,800	1250	2340	5340	9470	15,700	20,800
			200	13.8	1830	3320	7550	13,160	22,500	28,600	1830	3320	7550	13,400	28,100	32,800
			300	20.7	2700	4910	11,200	19,800	32,700	38,000	2700	4910	11,200	20,100	36,300	52,600
			500	34.5	4400	8090	18,300	32,500	43,800	51,700	4400	8090	18,300	32,900	70,800	109,000
			750	51.8	6600	12,000	27,200	48,300	49,900	71,400	6600	12,000	27,200	48,900	104,000	158,000
			1000	69.0	8700	16,000	36,100	50,000	52,900	72,000	8700	16,000	36,100	64,800	138,000	160,000
			1250	86.2	11,000	19,000	45,000	53,000	58,000		11,000	19,000	45,000	80,000	145,000	
			1500	103	13,000	22,000	51,000	56,000			13,000	22,000	54,000	96,000		
			1750	121	15,000	25,000	52,000	60,000			15,000	25,000	63,000	112,000		
	2000	138	17,000	28,000	53,000				17,000	28,000	71,000					
	150	10.3	200	13.8	1760	3200	7290	12,500	21,400	30,600	1760	3200	7290	12,900	21,400	33,600
			300	20.7	2700	4910	11,200	17,200	34,700	46,000	2700	4910	11,200	17,200	40,100	55,900
			500	34.5	4400	8090	18,300	32,500	48,900	59,700	4400	8090	18,300	32,900	70,300	111,000
			750	51.8	6600	12,000	27,200	48,300	59,000	72,000	6600	12,000	27,200	48,900	104,000	160,000
1000			69.0	8700	16,000	36,100	64,100	81,100	85,000	8700	16,000	36,100	64,800	138,000	162,000	
1250			86.2	11,000	19,000	45,000	68,000	90,000		11,000	19,000	45,000	80,000	150,000		
1500			103	13,000	22,000	54,000	72,000			13,000	22,000	54,000	96,000			
1750			121	15,000	25,000	63,000	77,000			15,000	25,000	63,000	112,000			
2000			138	17,000	28,000	71,000				17,000	28,000	71,000				

Outlet Pressure Range	Outlet Pressure Setting		Inlet Pressure		627 - 2" Body Size						627M - 2" Body Size					
	PSIG	BAR	PSIG	BAR	Port Diameter, inches						Port Diameter, inches					
					3/32	1/8	3/16	1/4	3/8	1/2	3/32	1/8	3/16	1/4	3/8	1/2
5 to 20 psig ² (0.34 to 1.4 BAR)	5 ³	0.34	10	0.69	170	330	710	1080	1700	2400	170	330	710	1080	1700	2400
			15	1.0	240	390	890	1250	1900	2700	240	390	890	1250	1900	2700
			20	1.4	290	500	1160	1900	2650	3900	290	500	1160	1900	2650	3900
			30	2.1	380	670	1560	2800	3680	6500	380	670	1560	2800	3680	6500
			60	4.1	640	1170	2600	4750	7250	17,800	640	1170	2600	4750	7250	15,000
			75	5.2	770	1410	3150	5700	8060	22,400	770	1410	3150	5700	8060	17,900
			100	6.9	990	1790	4070	7310	16,200	28,700	990	1790	4070	7310	14,600	23,000
	10	0.69	15	1.03	210	375	880	1220	1860	2670	210	375	880	1220	1860	2670
			20	1.4	280	490	1150	1880	2610	3830	280	490	1150	1880	2610	3830
			30	2.1	380	670	1560	2760	3640	6460	380	670	1560	2760	3640	6460
			60	4.1	640	1170	2600	4750	7250	17,800	640	1170	2600	4750	7250	15,000
			75	5.2	770	1410	3150	5700	8060	22,400	770	1410	3150	5700	8060	17,900
			100	6.9	990	1790	4070	7310	16,200	28,700	990	1790	4070	7310	14,600	23,000
			150	10.3	1420	2580	5850	10,500	23,300	25,900 ⁵	1420	2580	5850	10,500	21,000	33,000
			200	13.8	1850	3370	7630	13,700	22,700 ⁵	24,000 ⁵	1850	3370	7630	13,700	27,300	43,000
			300	20.7	2700	4910	11,200	10,300 ⁵	12,800 ⁵		2700	4910	11,200	20,100	40,100	
			500	34.5	4400	8090	18,300	21,000 ⁵			4400	8090	18,300	32,900		
	20	1.4	750	51.7	6600	12,000	27,200			6600	12,000	27,200				
			1000	69.0	8700	16,000				8700	16,000					
			1250	86.2	11,000					11,000						
			1500	103	13,000					13,000						
			1750	121	15,000					15,000						
			2000	138	17,000					17,000						
			30	2.1	350	620	1450	2350	4300	6110	350	620	1450	2480	4300	6110
50			3.4	550	1000	2280	4040	7100	12,800	550	1000	2280	4040	7100	12,800	
60			4.1	640	1170	2640	4750	8400	15,700	640	1170	2640	4750	8400	15,000	
100	6.9	990	1800	4070	7310	16,200	28,700	990	1800	4070	7310	14,600	23,000			
150	10.3	1420	2580	5850	10,500	23,300	29,000 ⁵	1420	2580	5850	10,500	21,000	33,000			
200	13.8	1850	3370	7630	13,700	24,000 ⁵	33,000 ⁵	1850	3370	7630	13,700	27,300	43,000			
300	20.7	2700	4910	11,200	20,100	19,600 ⁵		2700	4910	11,200	20,100	40,100				
500	34.5	4400	8090	18,300	32,900			4400	8090	18,300	32,900					
750	51.7	6600	12,000	27,200				6600	12,000	27,200						
1000	69.0	8700	16,000					8700	16,000							
1250	86.2	11,000						11,000								
1500	103	13,000						13,000								
1750	121	15,000						15,000								
2000	138	17,000						17,000								

- Capacity is based on 20 percent droop unless otherwise noted below.
- For pressure setting under 10 PSIG (0.69 BAR) limit the input pressure to 100 PSIG (6.9 BAR) to obtain the setpoint.
- For 5 PSIG (0.34 BAR) pressure set point, the droop is 2 PSIG (0.14 BAR)
- For 10 PSIG (0.69 BAR) pressure set point, the droop is 5 PSIG (0.34 BAR)
- Capacities are based on 25 percent boost if setting is less than 12 PSIG (0.8 BAR), 3 PSIG (0.2 BAR) boost if setting is from 12 to 60 PSIG (0.2 to 4 BAR), and 5 percent boost if setting is greater than 60 PSIG (4 BAR).

P627 Flow Capacities of Natural Gas (0.6 S.G.) in SCFH¹



Outlet Pressure Range	Outlet Pressure Setting		Inlet Pressure		627 – 2" Body Size						627M – 2" Body Size					
					Port Diameter, inches						Port Diameter, inches					
	PSIG	BAR	PSIG	BAR	3/32	1/8	3/16	1/4	3/8	1/2	3/32	1/8	3/16	1/4	3/8	1/2
15 to 40 PSIG (1.0 to 2.8 BAR)	40	2.8	60	4.1	610	1090	2530	4370	8680	13,300	610	1090	2530	4370	8680	13,300
			75	5.2	760	1370	3080	5540	11,900	19,300	760	1370	3080	5540	10,700	19,300
			100	6.9	990	1800	4070	7310	16,200	25,400	990	1800	4070	7310	14,600	25,400
			150	10.3	1420	2580	5850	10,500	23,300	41,300	1420	2580	5850	10,500	21,000	37,000
			200	13.8	1850	3370	7630	13,700	30,400	53,900	1850	3370	7630	13,700	27,300	48,000
			300	20.7	2700	4910	11,200	20,100	44,600	46,000 ⁵	2700	4910	11,200	20,100	40,100	71,000
			500	34.5	4400	8090	18,300	32,900	22,000 ⁵		4400	8090	18,300	32,900	65,000	
			750	51.7	6600	12,000	27,200	28,000 ⁵			6600	12,000	27,200	28,000 ⁵		
			1000	69.0	8700	16,000	36,100				8700	16,000	36,100			
			1250	86.2	11,000	19,000					11,000	19,000				
			1500	103	13,000	22,000					13,000	22,000				
			1750		15,000						15,000					
2000		17,000						17,000								
35 to 80 PSIG (2.4 to 5.5 BAR)	60	4.1	75	5.2	700	1260	2760	4900	9000	12,300	700	1230	2760	4900	9000	12,300
			100	6.9	970	1740	4010	7000	15,000	20,400	970	1740	4010	7000	15,000	20,400
			150	10.3	1420	2580	5850	10,500	23,300	35,200	1420	2580	5850	10,500	23,300	35,200
			200	13.8	1850	3370	7630	13,700	30,400	53,900	1850	3370	7630	13,700	30,400	48,500
			300	20.7	2700	4910	11,200	20,100	44,600	79,000 ⁵	2700	4910	11,200	20,100	44,600	71,000
			500	34.5	4400	8090	18,300	32,900	73,000 ⁵	38,800 ⁵	4400	8090	18,300	32,900	73,000	116,000
			750	51.8	6600	12,000	27,200	48,900 ⁵	53,000 ⁵	32,000	6600	12,000	27,200	48,900	108,000	172,000
			1000	69.0	8700	16,000	36,100	43,000 ⁵	52,000		8700	16,000	36,100	65,000	144,000	
			1250	86.2	11,000	19,000	45,000	70,000 ⁵			11,000	19,000	45,000	81,000		
			1500	103	13,000	22,000	54,000 ⁵	43,000			13,000	22,000	54,000	97,000		
	1750	121	15,000	25,000	26,000				15,000	25,000	63,000					
	2000	138	17,000	28,000					17,000	28,000						
	80	5.5	100	5.2	900	1630	3750	6400	12,000	20,400	900	1630	3750	6400	12,800	20,400
			150	10.3	1410	2580	5850	10,500	23,300	41,300	1410	2580	5850	10,500	23,300	37,200
			200	13.8	1850	3370	7630	13,700	30,400	53,900	1850	3370	7630	13,700	30,400	48,500
			300	20.7	2700	4910	11,200	20,100	44,600	79,000 ⁵	2700	4910	11,200	20,100	44,600	71,000
			500	34.5	4400	8090	18,300	32,900	73,000 ⁵	48,000 ⁵	4400	8090	18,300	32,900	73,000	116,000
			750	51.8	6600	12,000	27,200	48,900	87,000 ⁵	44,000	6600	12,000	27,200	48,900	108,000	172,000
1000			69.0	8700	16,000	36,100	65,000 ⁵	63,000		8700	16,000	36,100	65,000	144,000		
1250			86.2	11,000	19,000	45,000	63,000 ⁵			11,000	19,000	45,000	81,000			
1500			103	13,000	22,000	54,000	86,000			13,000	22,000	54,000	97,000			
1750			121	15,000	25,000	63,000				15,000	25,000	63,000				
2000	138	17,000	28,000					17,000	28,000							
70 to 150 PSIG (4.8 to 10.3 BAR)	100	6.9	150	10.3	1170	2510	5540	8600	16,000	22,000	1170	2510	5540	8600	16,000	22,000
			200	13.8	1850	3370	7630	13,700	22,000	33,000	1850	3370	7630	13,700	22,000	33,000
			300	20.7	2700	4910	11,200	20,100	35,000	65,300	2700	4910	11,200	20,100	35,000	59,000
			500	34.5	4400	8090	18,300	32,900	73,000	129,000	4400	8090	18,300	32,900	73,000	116,000
			750	51.8	6600	12,000	27,200	48,900	108,000	54,000 ⁵	6600	12,000	27,200	48,900	108,000	172,000
			1000	69.0	8700	16,000	36,100	64,800	82,000 ⁵		8700	16,000	36,100	64,800	144,000	
			1250	86.2	11,000	19,000	45,000	80,000	110,000 ⁵		11,000	19,000	45,000	80,000	179,000	
			1500	103	13,000	22,000	54,000	96,000			13,000	22,000	54,000	96,000		
			1750	121	15,000	25,000	63,000	112,000			15,000	25,000	63,000	112,000		
			2000	138	17,000	28,000	71,000				17,000	28,000	71,000			
	125	8.6	150	10.3	1250	2340	5340	8600	16,000	24,000	1250	2340	5340	8600	16,000	24,000
			200	13.8	1830	3320	7550	13,000	24,000	36,000	1830	3320	7550	13,000	24,000	36,000
			300	20.7	2700	4910	11,200	20,100	39,000	65,300	2700	4910	11,200	20,100	39,000	59,000
			500	34.5	4400	8090	18,300	32,900	73,000	129,000	4400	8090	18,300	32,900	73,000	116,000
			750	51.8	6600	12,000	27,200	48,900	108,000	59,000 ⁵	6600	12,000	27,200	48,900	108,000	172,000
			1000	69.0	8700	16,000	36,100	64,800	58,000 ⁵		8700	16,000	36,100	64,800	144,000	
			1250	86.2	11,000	19,000	45,000	80,000	75,000 ⁵		11,000	19,000	45,000	80,000	179,000	
			1500	103	13,000	22,000	54,000	96,000			13,000	22,000	54,000	96,000		
1750			121	15,000	25,000	63,000	112,000			15,000	25,000	63,000	112,000			
2000			138	17,000	28,000	71,000				17,000	28,000	71,000				
150	10.3	200	13.8	1760	3200	7290	13,000	24,000	38,000	1760	3200	7290	13,000	24,000	38,000	
		300	20.7	2700	4910	11,200	20,100	44,600	64,200	2700	4910	11,200	20,100	44,600	58,000	
		500	34.5	4400	8090	18,300	32,900	73,000	129,000	4400	8090	18,300	32,900	73,000	116,000	
		750	51.8	6600	12,000	27,200	48,900	108,000	62,000 ⁵	6600	12,000	27,200	48,900	108,000	172,000	
		1000	69.0	8700	16,000	36,100	64,800	144,000		8700	16,000	36,100	64,800	144,000		
		1250	86.2	11,000	19,000	45,000	80,000	81,000 ⁵		11,000	19,000	45,000	80,000	179,000		
		1500	103	13,000	22,000	54,000	96,000			13,000	22,000	54,000	96,000			
		1750	121	15,000	25,000	63,000	112,000			15,000	25,000	63,000	112,000			
2000	138	17,000	28,000	71,000				17,000	28,000	71,000						

1. Capacity is based on 20 percent droop unless otherwise noted below.
 5. Capacities are based on 25 percent boost if setting is less than 12 PSIG (0.8 BAR), 3 PSIG (0.2 BAR) boost if setting is from 12 to 60 PSIG (0.2 to 4 BAR), and 5 percent boost if setting is greater than 60 PSIG (4 BAR).

P627 Flow Capacities of Natural Gas (0.6 S.G.) in SCFH¹

Outlet Pressure Range	Outlet Pressure Setting		Inlet Pressure		627H or HM – 3/4" Body Size						627H or HM – 1" Body Size							
	PSIG	BAR	PSIG	BAR	Port Diameter, inches						Port Diameter, inches							
					3/32	1/8	3/16	1/4	3/8	1/2	3/32	1/8	3/16	1/4	3/8	1/2		
140 to 250 PSIG (9.7 to 17.2 BAR)	150	10.3	200	13.8	1760 ⁶	3200 ⁴	7290	11,500	21,600	31,000	1760 ⁶	3200 ⁴	7290	11,500	21,600	31,000		
			250	17.2	2260 ⁶	4100 ⁴	9200	15,400	28,600	40,000	2260 ⁶	4100 ⁴	9200	15,400	28,600	40,000		
			300	20.7	2700	4910	11,200	19,300	31,000	46,000	2700	4910	11,200	19,300	31,000	46,000		
			400	27.6	3600	6500	14,800	24,700	40,000	50,000	3600	6500	14,800	25,000	40,000	50,000		
			500	34.5	4400	8090	18,300	29,700	51,000		4400	8090	18,300	32,000	51,000			
			750	51.7	6600	12,000	27,200	43,000			6600	12,000	27,200	46,000				
			1000	69.0	8700	16,000	36,100	57,000			8700	16,000	36,100	60,000				
			1250	86.2	11,000	19,000	45,000				11,000	19,000	45,000					
			1500	103	13,000	22,000	54,000				13,000	22,000	54,000					
			1750	121	15,000	25,000	63,000				15,000	25,000	63,000					
	2000	138	17,000	28,000					17,000	28,000								
	200	13.8	250	17.2	2160 ⁶	3850 ⁴	8400	15,000	31,000	41,000	2160 ⁶	3850 ⁴	8400	15,000	31,000	41,000		
			300	20.7	2700 ⁶	4910 ⁴	11,200	19,500	36,000	52,000	2700 ⁶	4910 ⁴	11,200	19,500	36,000	52,000		
			400	27.6	3600	6500	14,800	25,500	52,000	68,000	3600	6500	14,800	26,500	52,000	68,000		
			500	34.5	4400	8090	18,300	31,000	61,000		4400	8090	18,300	33,000	61,000			
			750	51.7	6600	12,000	27,200	45,500			6600	12,000	27,200	49,000				
			1000	69.0	8700	16,000	36,100	60,000			8700	16,000	36,100	65,000				
			1250	86.2	11,000	19,000	45,000				11,000	19,000	45,000					
			1500	103	13,000	22,000	54,000				13,000	22,000	54,000					
			1750	121	15,000	25,000	63,000				15,000	25,000	63,000					
			2000	138	17,000	28,000					17,000	28,000						
	250	17.2	300	20.7	2500 ⁶	4500 ⁴	9900	18,500	37,000	52,000	2500 ⁶	4500 ⁴	9900	18,500	37,000	52,000		
			400	27.6	3600 ⁶	6400 ⁴	14,300	26,000	55,000	74,000	3600 ⁶	6400 ⁴	14,300	26,000	55,000	81,000		
			500	34.5	4400	8090	18,300	33,000	64,000	87,000	4400	8090	18,300	33,000	64,000	95,000		
			750	51.7	6600	12,000	27,200	49,000	93,000		6600	12,000	27,200	49,000	102,000			
			1000	69.0	8700	16,000	36,100	65,000			8700	16,000	36,100	65,000				
			1250	86.2	11,000	19,000	45,000	81,000			11,000	19,000	45,000	81,000				
			1500	103	13,000	22,000	54,000				13,000	22,000	54,000					
1750			121	15,000	25,000	63,000				15,000	25,000	63,000						
2000			138	17,000	28,000	71,000				17,000	28,000	71,000						
240 to 500 PSIG (16.5 to 34.5 BAR)			250	17.2	300	20.7	2500 ⁶	4500 ⁴	9300	14,000	25,000	37,000	2500 ⁶	4500 ⁴	9300	14,000	25,000	37,000
	400	27.6			3600 ⁶	6400 ⁴	14,300	21,400	36,000	49,000	3600 ⁶	6400 ⁴	14,300	21,400	36,000	49,000		
	500	34.6			4400	8090	18,300	26,300	42,000	62,000	4400	8090	18,300	26,300	42,000	62,000		
	750	51.7			6600	12,000	27,200	37,100	57,000		6600	12,000	27,200	37,100	57,000			
	1000	69.0			8700	16,000	36,100	47,400			8700	16,000	36,100	47,400				
	1250	86.2			11,000	19,000	45,000	57,000			11,000	19,000	45,000	57,000				
	1500	103			13,000	22,000	54,000				13,000	22,000	54,000					
	1750	121			15,000	25,000	63,000				15,000	25,000	63,000					
	2000	138			17,000	28,000	71,000				17,000	28,000	71,000					
	300	20.7			350	24.1	2900 ⁶	5150 ⁴	11,300	18,400	31,000	45,000	2900 ⁶	5150 ⁴	11,300	18,400	31,000	45,000
			400	27.6	3500 ⁶	6200 ⁴	13,700	23,400	40,000	52,000	3500 ⁶	6200 ⁴	13,700	23,400	40,000	52,000		
			500	34.5	4400	8090	18,300	32,000	53,000	67,000	4400	8090	18,300	32,000	53,000	67,000		
			750	51.7	6600	12,000	27,200	48,000	80,000		6600	12,000	27,200	48,000	80,000			
			1000	69.0	8700	16,000	36,100	62,000			8700	16,000	36,100	62,000				
			1250	86.2	11,000	19,000	45,000	79,000			11,000	19,000	45,000	79,000				
			1500	103	13,000	22,000	54,000				13,000	22,000	54,000					
			1750	121	15,000	25,000	63,000				15,000	25,000	63,000					
	2000	138	17,000	28,000	71,000				17,000	28,000	71,000							
240 to 500 PSIG (16.5 to 34.5 BAR)	400	27.6	450	31.0	3600 ⁶	6400 ⁴	14,000	25,000	47,000	67,000	3600 ⁶	6400 ⁴	14,000	25,000	47,000	67,000		
			500	34.6	4400 ⁶	8090 ⁴	18,300	32,000	54,000	77,000	4400 ⁶	8090 ⁴	18,300	32,000	54,000	77,000		
			750	51.7	6600	12,000	27,200	49,000	91,000		6600	12,000	27,200	49,000	91,000			
			1000	69.0	8700	16,000	36,100	65,000			8700	16,000	36,100	65,000				
			1250	86.2	11,000	19,000	45,000	81,000			11,000	19,000	45,000	81,000				
			1500	103	13,000	22,000	54,000				13,000	22,000	54,000					
			1750	121	15,000	25,000	63,000				15,000	25,000	63,000					
			2000	138	17,000	28,000	71,000				17,000	28,000	71,000					
			500	34.5	550	37.9	4300 ⁶	7700 ⁴	16,800	33,000	62,000	90,000	4300 ⁶	7700 ⁴	16,800	33,000	62,000	90,000
					600	47.4	4900 ⁶	8800 ⁴	19,400	37,000	70,000	104,000	4900 ⁶	8800 ⁴	19,400	37,000	70,000	104,000
	750	51.7			6600	12,000	27,200	49,000	88,000	137,000	6600	12,000	27,200	49,000	88,000	140,000		
	1000	69.0			8700	16,000	36,100	65,000	130,000		8700	16,000	36,100	65,000	130,000			
	1250	86.2			11,000	19,000	45,000	81,000			11,000	19,000	45,000	81,000				
	1500	103			13,000	22,000	54,000	97,000			13,000	22,000	54,000	97,000				
	1750	121			15,000	25,000	63,000				15,000	25,000	63,000					
	2000	138			17,000	28,000	71,000				17,000	28,000	71,000					

1. Capacity is based on 20 percent droop unless otherwise noted below.
 4. Outlet pressure setting may shift ± 15 PSIG.
 6. Small orifices and low pressure drops may cause the set point to shift + 15 PSIG (1.3 BAR).

P627 Flow Capacities of Natural Gas (0.6 S.G.) in SCFH¹



Outlet Pressure Range	Outlet Pressure Setting		Inlet Pressure		627H or HM – 2" Body Size							
					Port Diameter, inches							
	PSIG	BAR	PSIG	BAR	3/32	1/8	3/16	1/4	3/8	1/2		
140 to 250 PSIG (9.7 to 17.2 BAR)	150	10.3	200	13.8	1760 ⁶	3200 ⁴	7290	13,700	24,100	31,000		
			250	17.2	2260 ⁶	4100 ⁴	9200	16,100	28,600	40,000		
			300	20.7	2700	4910	11,200	19,300	31,000	46,000		
			400	27.6	3600	6500	14,800	25,000	40,000	50,000		
			500	34.5	4400	8090	18,300	32,000				
			750	51.7	6600	12,000	27,200	48,000				
			1000	69.0	8700	16,000	36,100	65,000				
			1250	86.2	11,000	19,000	45,000					
			1500	103	13,000	22,000	54,000					
			1750	121	15,000	25,000	63,000					
	2000	138	17,000	28,000								
	200	13.8	250	17.2	2160 ⁶	3850 ⁴	8400	16,100	33,000	41,000		
			300	20.7	2700 ⁶	4910 ⁴	11,200	20,100	36,000	52,000		
			400	27.6	3600	6500	14,800	26,500	52,000	68,000		
			500	34.5	4400	8090	18,300	33,000	61,000			
			750	51.7	6600	12,000	27,200	49,000				
			1000	69.0	8700	16,000	36,100	65,000				
			1250	86.2	11,000	19,000	45,000					
			1500	103	13,000	22,000	54,000					
			1750	121	15,000	25,000	63,000					
			2000	138	17,000	28,000						
	250	17.2	300	20.7	2500 ⁶	4500 ⁴	9900	18,500	37,000	75,000		
			400	27.6	3600 ⁶	6400 ⁴	14,300	26,000	55,000	81,000		
			500	34.5	4400	8090	18,300	33,000	64,000	95,000		
750			51.7	6600	12,000	27,200	49,000	102,000				
1000			69.0	8700	16,000	36,100	65,000					
1250			86.2	11,000	19,000	45,000	81,000					
1500			103	13,000	22,000	54,000						
1750			121	15,000	25,000	63,000						
2000			138	17,000	28,000	71,000						
240 to 500 PSIG (16.5 to 34.5 BAR)			250	17.2	300	20.7	2500 ⁶	4500 ⁴	9300	14,000	25,000	37,000
	400	27.6			3600 ⁶	6400 ⁴	14,300	21,400	36,000	49,000		
	500	34.6			4400	8090	18,300	26,300	42,000	62,000		
	750	51.7			6600	12,000	27,200	37,100	57,000			
	1000	69.0			8700	16,000	36,100	47,400				
	1250	86.2			11,000	19,000	45,000	57,000				
	1500	103			13,000	22,000	54,000					
	1750	121			15,000	25,000	63,000					
	2000	138			17,000	28,000	71,000					
	300	20.7			350	24.1	2900 ⁶	5150 ⁴	11,300	18,400	31,000	45,000
400			27.6	3500 ⁶	6200 ⁴	13,700	23,400	40,000	52,000			
500			34.5	4400	8090	18,300	32,000	53,000	67,000			
750			51.7	6600	12,000	27,200	48,000	80,000				
1000			69.0	8700	16,000	36,100	62,000					
1250			86.2	11,000	19,000	45,000	79,000					
1500			103	13,000	22,000	54,000						
1750			121	15,000	25,000	63,000						
2000			138	17,000	28,000	71,000						
240 to 500 PSIG (16.5 to 34.5 BAR)			400	27.6	450	31.0	3600 ⁶	6400 ⁴	14,000	25,000	47,000	67,000
	500	34.6			4400 ⁶	8090 ⁴	18,300	32,000	54,000	77,000		
	750	51.7			6600	12,000	27,200	49,000	91,000			
	1000	69.0			8700	16,000	36,100	65,000				
	1250	86.2			11,000	19,000	45,000	81,000				
	1500	103			13,000	22,000	54,000					
	1750	121			15,000	25,000	63,000					
	2000	138			17,000	28,000	71,000					
	500	34.5			550	37.9	4300 ⁶	7700 ⁴	16,800	33,000	62,000	90,000
					600	47.4	4900 ⁶	8800 ⁴	19,400	37,000	70,000	104,000
750			51.7	6600	12,000	27,200	49,000	88,000	140,000			
1000			69.0	8700	16,000	36,100	65,000	130,000				
1250			86.2	11,000	19,000	45,000	81,000					
1500			103	13,000	22,000	54,000	97,000					
1750			121	15,000	25,000	63,000						
2000			138	17,000	28,000	71,000						

- 1. Capacity is based on 20 percent droop unless otherwise noted below.
- 4. Outlet pressure setting may shift ± 15 PSIG.
- 6. Small orifices and low pressure drops may cause the set point to shift + 15 PSIG (1.3 BAR).

P627 Flow Coefficients

Orifice Size		3/4 Inch Body			1 Inch (DIN 25) Body			2 Inch (DIN 50) Body			K
Inches	mm	Wide-Open C _v for External Relief Sizing	Wide-Open C _v for External Relief Sizing	C ₁	Wide-Open C _v for External Relief Sizing	Wide-Open C _v for External Relief Sizing	C ₁	Wide-Open C _v for External Relief Sizing	Wide-Open C _v for External Relief Sizing	C ₁	
3/32	2.4	6.9	0.24	29.2	6.9	0.24	28.5	6.9	0.23	29.7	0.72
1/8	3.2	12.5	0.43	29.1	12.5	0.43	29.4	12.5	0.42	29.5	0.62
3/16	4.8	29	1.01	28.6	29	0.93	31.2	29	1.02	28.5	0.72
1/4	6.4	50	1.63	30.5	50	1.71	29.3	52	1.66	31.3	0.76
3/8	9.5	108	2.99	36.1	108	3.42	31.6	115	3.39	33.9	0.79
1/2	12.7	190	4.87	39.0	190	5.29	35.9	200	5.01	39.9	.074

P627 Parts

Item	Description	Qty.	Part Number
1	Cover Adj. Screw, Plastic	1	610-053-000
2	Adjustment Screw	1	648-465-000
3	Locknut	1	634-154-000
4	Bonnet, P627 - Aluminum	1	604-210-000
	Bonnet, P627M, P627H & P627HM - Steel		604-211-000
	Bonnet, P627 - Stainless		604-266-000
5	Vent Screw Assembly	1	836-005-000
6	Spring Guide, Upper	1	626-079-000
7	Range Spring	1	
	5-20 PSIG–Yellow		655-661-000
	15-40 PSIG–Green		655-661-001
	35-80 PSIG & 10-95–PSIG Blue		655-661-002
	70-150 PSIG–Red		655-661-003
	140-250 PSIG–Blue		655-661-002
	240-500 PSIG–Red		655-661-003
8	Spring Guide, Lower (P627 or P627M only)	1	643-191-000
9	Al Spring Case Screws - P627	8	648-466-000
	Steel Spring Case Screws - P627 or P627M		648-467-003
	Steel Spring Case Screws - P627H or P627HM		648-467-002
	SS Spring Case Screws - P627 or P627M		648-550-000
	SS Spring Case Screws - P627H or P627HM		648-550-001
10	Diaphragm Piston (P627 or P627M only)	1	637-306-000
11	Diaphragm P627 & P627M Al / Iron (Nitrile)	1	618-069-000
	Diaphragm P627 & P627M Steel / SS (Nitrile)		618-070-000
	Diaphragm P627H & P627HM Steel / SS (Neoprene)		618-070-001
	Diaphragm P627 & P627M Al / Iron (Fluoro)		618-069-001
	Diaphragm P627 & P627M Steel / SS (Fluoro)		618-096-000
	Diaphragm P627H & P627HM Steel / SS (Fluoro)		618-096-001
12	Screw, Diaphragm P627 & P627M	1	648-466-002
	Screw, Diaphragm P627H & P627HM	1	648-467-000
13	Post, Pusher P627 & P627M Assy	1	827-005-000
	Post, Pusher P627H & P627HM Assy		827-005-001
	Post, Pusher P627 & P627M, NACE		827-008-000
	Post, Pusher P627H & P627HM, NACE		827-008-001
14	Diaphragm Case P627 - Aluminum	1	629-202-000
	Diaphragm Case P627 & P627H - Steel		629-203-000
	Diaphragm Case P627M & P627HM- Steel		629-204-000
	Diaphragm Case, Aluminum (for Steel Body)		629-215-000
	Diaphragm Case P627 - Stainless		629-242-000
	Diaphragm Case P627H - Stainless		629-243-000
15	Lever, Stainless	1	703-011-000
	Lever		703-004-000
	Lever, NACE		703-005-000
16	Lever Screw	2	648-466-002
	Lever Screw, NACE		648-474-000
17	Pin, Lever	1	635-053-000
	Pin, Lever, NACE		635-057-000
18	Lever Retainer, Stainless	1	643-210-000
	Lever Retainer		643-192-000
	Lever Retainer, NACE		643-194-000
19	Stem O-ring, Nitrile	1	649-000-003
20	Stem Backup Ring, TFE	2	644-047-000
21	Pin, Groove, Stainless	1	635-076-000
	Pin, Groove		635-054-000
	Pin, Groove, Nace		635-058-000
22	Stem Guide	1	626-083-000
23	Pin Clip	1	635-055-000
	Pin Clip NACE		635-056-000

Item	Description	Qty.	Part Number
24	Stem, 316SS	1	689-005-000
25	Diaphragm Case O-ring, Nitrile (P627 & P627H)	1	649-280-000
26	Boost Body P627 or P627H	1	686-003-000
27	Stabilizer, Nitrile P627 or P627H	1	649-278-000
28	Seat assembly - Aluminum holder/nitrile disk	1	822-019-000
	Seat assembly - Aluminum / Nylon		822-019-001
	Seat assembly - Aluminum / Fluorocarbon		822-040-000
	Seat assembly - 316SS Holder / Nitrile		822-020-000
	Seat assembly - 316SS / Nylon		822-020-001
	Seat assembly - 316SS / Fluorocarbon		822-040-001
29	Orifice - Aluminum - 3/32"	1	688-013-005
	Orifice - Aluminum - 1/8"		688-013-004
	Orifice - Aluminum - 3/16"		688-013-003
	Orifice - Aluminum - 1/4"		688-013-002
	Orifice - Aluminum - 3/8"		688-013-001
	Orifice - Aluminum - 1/2"		688-013-000
	Orifice - 316SS - 3/32"		688-014-005
	Orifice - 316SS - 1/8"		688-014-004
	Orifice - 316SS - 3/16"		688-014-003
	Orifice - 316SS - 1/4"		688-014-002
30	Orifice - 316SS - 3/8"	1	688-014-001
	Orifice - 316SS - 1/2"		688-014-000
	Iron Body - 3/4 NPT		664-280-000
	Iron Body - 1 NPT		664-280-001
	Iron Body - 2 NPT		664-282-000
	Steel Body - 3/4 NPT		664-281-000
	Steel Body - 1 NPT		664-281-001
	Steel Body - 2 NPT		664-283-000
	LCC Body - 3/4 NPT		664-325-000
	LCC Body - 1 NPT LCC		664-325-001
	LCC Body - 2 NPT LCC		664-326-000
	Stainless Body - 3/4 NPT		664-394-000
	Stainless Body - 1 NPT		664-394-001
	Stainless Body - 2 NPT		664-395-000
	Steel - 3/4 NPT Socket Weld		664-356-000
	Steel - 1 NPT Socket Weld		664-358-000
	Steel - 2 NPT Socket Weld		664-359-000
	Stainless - 3/4" Socket Weld		664-422-000
	Stainless - 1" Socket Weld		664-423-000
	Stainless - 2" Socket Weld		664-424-000
32	Diaphragm Spacer (P627H or P627HM only)	1	654-167-000
33	O-ring, Spacer (P627H or P627HM only)	1	649-279-000
34	O-ring, Throat Block	2	649-281-000
35	Throat Block (P627M or P627HM only)	1	626-081-000
36	Backup Ring, Throat Block	2	644-048-000
37	Steel Build Bolt / 1" Aluminum Housing	2	648-466-001
	Steel Build Bolt / 2" Aluminum Housing		648-466-003
	Steel Build Bolt / Steel Housing		648-467-001
	Stainless Build Bolt / 1" Aluminum Housing		648-548-001
	Stainless Build Bolt / 2" Aluminum Housing		648-548-003
	Stainless Build Bolt / Steel or SS Housing		648-549-000
38	Spring Guide, Lower (P627H & P627HM only)	1	637-307-000
40	Name Plate Drive Screw (not shown)	2	648-464-000
41	NACE Tag (not shown)	1	632-503-000

P627 / R627 Dimensions
Aluminum/Cast Ductile Iron Units

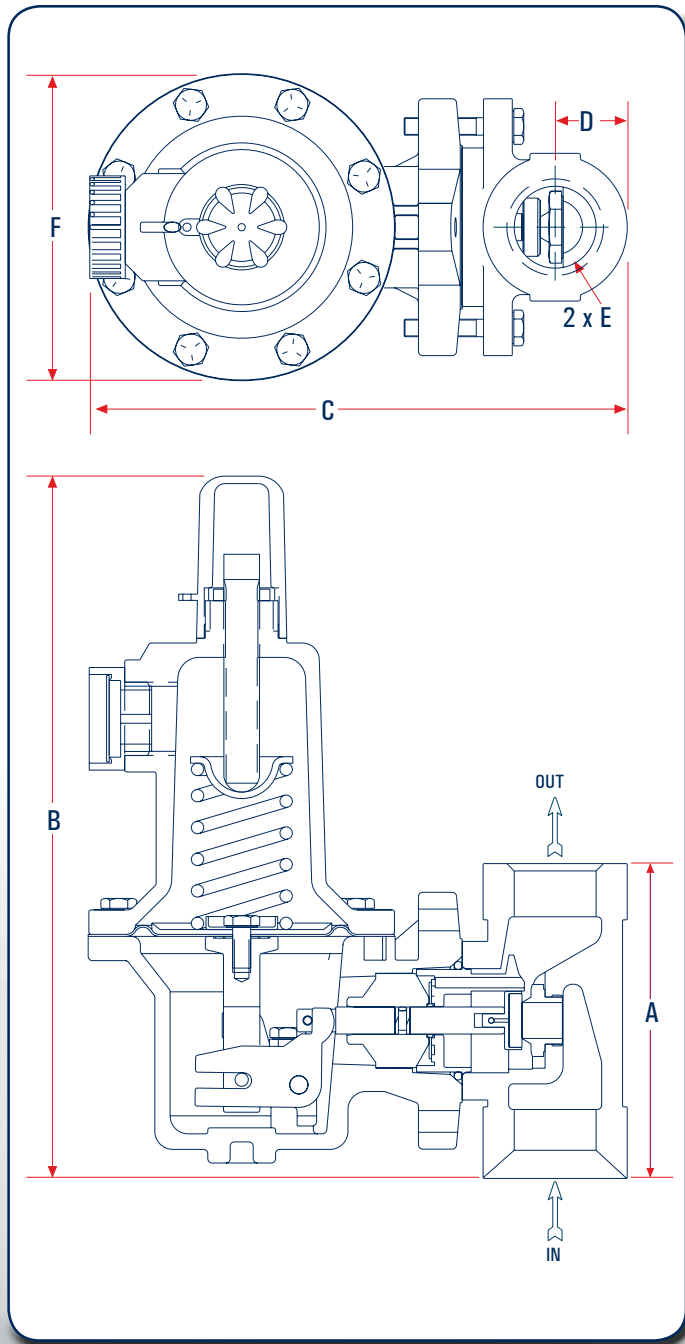

Type	Body Size		A	B	C	D	E	F*
627 & 627M	3/4"	mm	104	243	190	26	3/4"	108
		inches	4.08	9.54	7.46	1.0		4.25
	1"	mm	104	243	190	26	1"	108
		inches	4.08	9.54	7.46	1.0		4.25
	2"	mm	127	256	218	43	2"	108
		inches	5.0	10.06	8.56	1.69		4.25
627H & 627HM	3/4"	mm	104	250	194	26	3/4"	120
		inches	4.08	9.82	7.62	1.0		4.70
	1"	mm	104	250	194	26	1"	120
		inches	4.08	9.82	7.62	1.0		4.70
	2"	mm	127	265	224	43	2"	120
		inches	5.0	10.44	8.80	1.69		4.70

*F Dimensions for steel P627 and P627M - 120 mm/4.7 inches

P627H

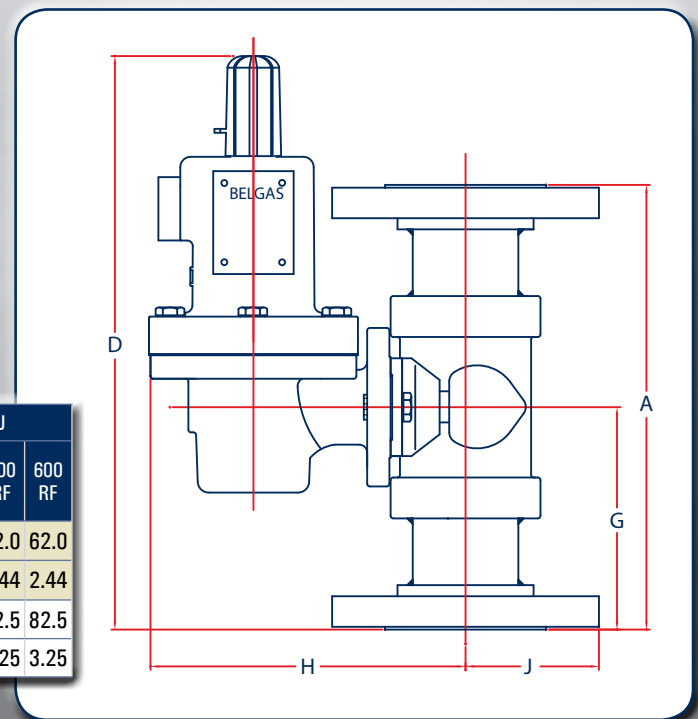
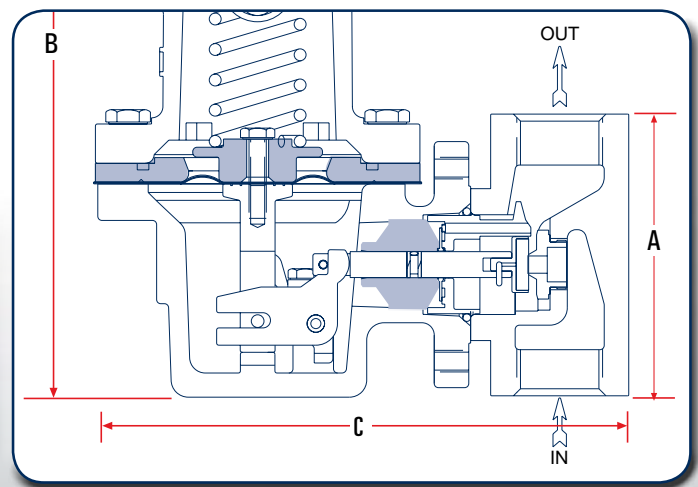

P627 / R627 Dimensions
Flange Units

Type	Body Size	A			D			G			Steel	J			
		150 RF	300 RF	600 RF	150 RF	300 RF	600 RF	150 RF	300 RF	600 RF		150 RF	300 RF	600 RF	
P627 & R627 Flanged Units	1"	mm	184	197	210	286	292	298	91.9	98.6	105	172	53.8	62.0	62.0
		in.	7.25	7.75	8.25	11.24	11.5	11.75	3.62	3.88	4.12	6.75	2.12	2.44	2.44
	2"	mm	254	267	286	321	327	337	127	133	143	181	76.2	82.5	82.5
		in.	10	10.5	11.25	12.63	12.88	13.25	5	5.25	5.62	7.12	3	3.25	3.25

R627 High Flow Gas Regulator with Internal Relief

The R627 Relieving Regulator has an internal relief valve that provides protection against over pressurization. As output pressure builds up above the start-to-discharge point the relief seat disengages from the diaphragm and the excess pressure is relieved through the bonnet vent port. As a result, the output pressure reduces and returns to the initial setpoint. The relief seat then reseats against the diaphragm. The action of the R627 internal relief valve in many cases eliminates the need for an external relief valve. The R627 is available in spring ranges from 5-20 PSIG up to 70-150 PSIG.

The R627 contains a relief indicator that is attached to the R627 vent assembly. The indicator pops off the vent when the relief valve opens and serves as a visual indicator that the relief valve has operated.



Applications

- Farm Tap
- Gas Gathering
- City Gates
- District Gates

Materials of Construction

Body, Bonnet, Diaphragm Case	
Options	Steel Body, Bonnet & Diaphragm Case
	Cast Ductile Iron Body / Aluminum Bonnet & Diaphragm Case
	Steel Body / Aluminum Bonnet & Diaphragm Case (NACE only)
	Steel Casing / LCC Body
	Aluminum Casing / LCC Body
	CF8M Stainless Steel Body, Bonnet & Diaphragm Case
Diaphragm	
Option	Nitrile (low pressure)
Seat	
Options	Nitrile
	Nylon
	Fluorocarbon
Orifice	
Options	Aluminum
	Stainless Steel (NACE only)

Specifications

Maximum Inlet Body Pressure		
Nylon Seat	2000 PSIG	Steel
	1000 PSIG	Ductile Iron
	1485 PSIG	Flanged Steel
Nitrile Seat	1000 PSIG	All Units
Fluorocarbon Seat	300 PSIG	All Units
Outlet		
	5-150 PSIG	
Body Sizes		
	3/4 NPT	
	1 NPT	
	2 NPT	
Orifice Sizes		
	3/32"	
	1/8"	
	3/16"	
	1/4"	
	3/8"	
	1/2"	
Output		
	Outlet Range	Flow Range*
	5-20 PSIG	300-43,000
	15-40 PSIG	1,000-71,000
	35-80 PSIG	1,200-142,000
	10-95 PSIG	1,000-150,000
	70-150 PSIG	2,500-172,000
	* (SCFH of 0.6 S.G. Natural Gas)	
Temperature Range		
	-20° to 180° F	(-29° to 82° C)
Weight Approximate		
1"	5.3 lbs	2.39 kg
2"	8.8 lbs	3.96 kg

Maximum Bonnet and Diaphragm Casing Pressure	Spring & Diaphragm Casing Style	R627		R627M	
		PSIG	BAR	PSIG	BAR
Maximum pressure to spring and diaphragm casing to prevent leak to atmosphere (internal parts damage may occur).	Die Cast Aluminum	250	17.2	250	250
	Steel / SS	250	17.2	250	17.2
Maximum pressure to spring and diaphragm casings to prevent burst of casings during abnormal operation (leak to atmosphere and internal parts may occur).	Die Cast Aluminum	375	25.9	375	375
	Steel / SS	1200	82.7	1200	82.7
Maximum diaphragm casing overpressure to prevent damage to internal parts.	All	60	4.1	60	4.1

R627 Regulator Rebuild Kits

	Kit Includes	Part Number
R627 Nitrile	Nitrile diaphragms (2), Nitrile valve disk, O-rings, back-up rings, and retaining pin	971-R62-700
R627 Nylon	Nitrile diaphragms (2), Nylon valve disk, O-rings, back-up rings, and retaining pin.	971-R62-701

	Kit Includes	Part Number
R627 Nitrile NACE	Nitrile diaphragms (2), SS Nitrile valve disk, O-rings, back-up rings, and retaining pin	971-R62-7N0
R627 Nylon NACE	Nitrile diaphragms (2), SS Nylon valve disk, O-rings, back-up rings, and retaining pin	971-R62-7N1

R627 Part Matrix

R627									1	
	▲	▲	▲	▲	▲	▲	▲	▲	▲	Port Size
	06									3/4"
	08									1"
	16									2"
										Spring Range
										PSIG BAR
	020									5 - 20 0.34 - 1.4
	040									15 - 40 1 - 2.8
	080									35 - 80 2.4 - 5.5
	095									10 - 95 0.7 - 6.6
	150									70 - 150 4.8 - 10.3
										NOTE: Nitrile or FKM is required for 5-20, 15-40 and 10-95 PSIG. Nylon is recommended only up to 1/8" orifice for these pressure ranges.
										Special Adders
	0									None
	2									Monitor
	A									150 #RF*
	B									300 #RF*
	C									600 #RF*
	D									Socket Weld*
	E									900 #RTJ*
	W									150 #RF & Monitor*
	X									300 #RF & Monitor*
	Y									600 #RF & Monitor*
	Z									Socket Weld & Monitor*
										*Steel, LCC Steel or Stainless Steel Bodies Only
										Versions
	0									Standard
	N									NACE
	F									NACE & Fluorocarbon
	T									Stainless Trim
										Orifice
	0									3/32"
	2									1/8"
	3									3/16"
	4									1/4"
	6									3/8"
	8									1/2"
										Seat Material
	0									Nitrile
	1									Nylon
	2									Fluorocarbon
										NOTE: Nitrile or FKM is required for 5-20, 15-40 and 10-95 PSIG. Nylon is recommended only up to 1/8" orifice for these pressure ranges.
										1
										Case / Body
	0									Aluminum / Iron
	1									Steel / Steel
	2									Aluminum / Steel
	6									Aluminum / LCC Steel
	7									Steel / LCC Steel
	8									Steel / Iron
	9									Stainless / Stainless

R627 Relief Performance - 1/4" Orifice

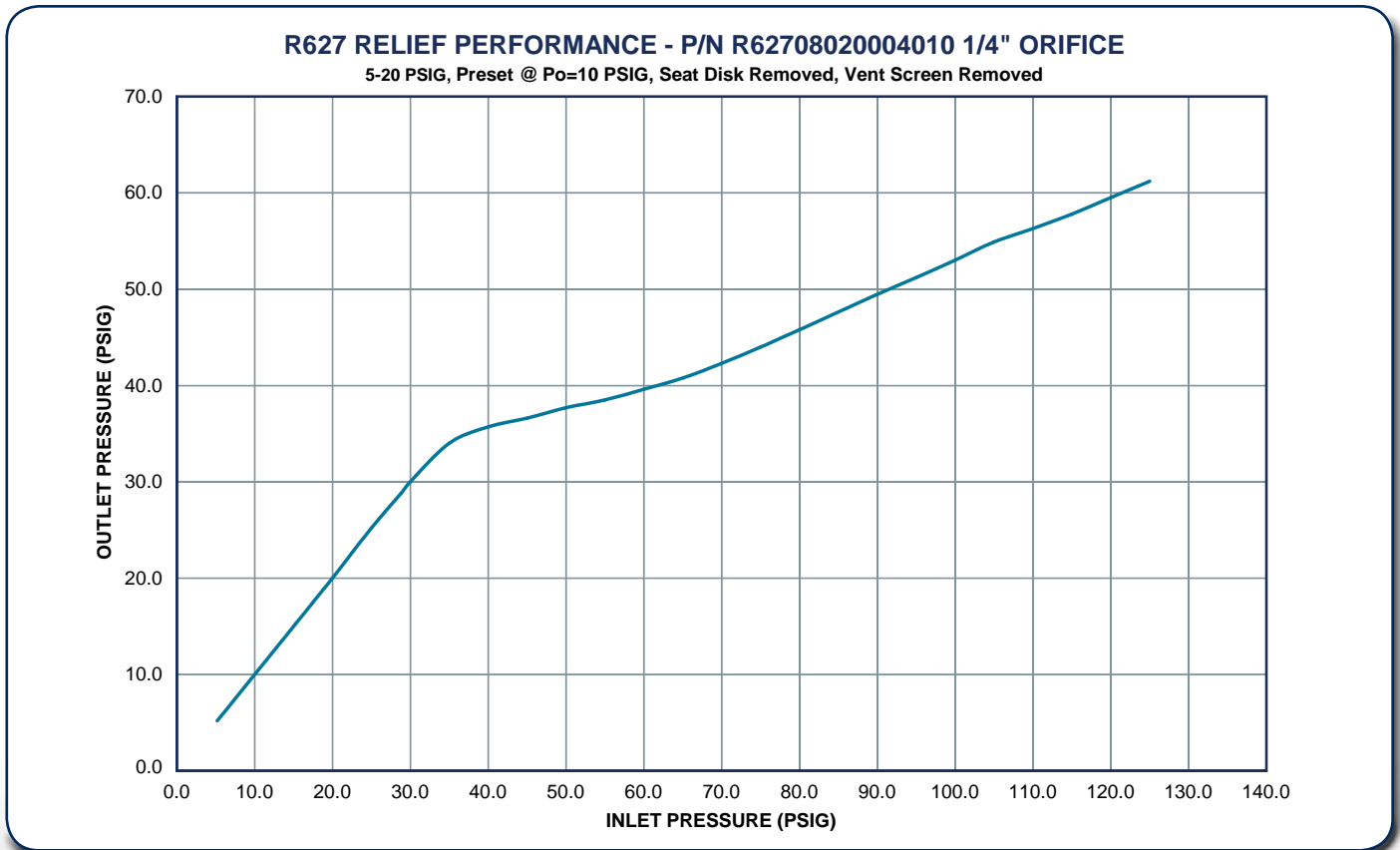

R627 Internal Relief Performance¹

Outlet Pressure Spring Range	Outlet Pressure Setting	Maximum Allowable Downstream Pressure	Maximum Inlet Pressure to Keep Maximum Allowable Downstream Pressure from Being Exceeded ²							
			R627							
			Port Diameter, inches							
PSIG	BAR	PSIG	BAR	3/32	1/8	3/16	1/4	3/8	1/2	
5 to 20 PSIG ³ (.03 to 1.4 BAR)	10	0.7	60	4.1	1250	740	320	190	95	75
			100	6.9	2000	1500	620	390	180	130
			125	8.6	2000	1900	830	480	220	160
			175	12.1	2000	2000	1100	670	320	220
			200	13.8	2000	2000	1300	770	360	260
			250	17.2	2000	2000	1600	960	450	320
	15	1.0	60	4.1	1000	620	260	170	90	70
			100	6.9	2000	1400	610	370	170	130
			125	8.6	2000	1900	810	480	220	160
			175	12.1	2000	2000	1100	670	320	220
			200	13.8	2000	2000	1300	770	360	260
			250	17.2	2000	2000	1600	960	450	320
	20	1.4	60	4.1	850	490	210	130	80	65
			100	6.9	2000	1300	600	360	170	120
			125	8.6	2000	1800	800	480	220	160
			175	12.1	2000	2000	1100	670	320	220
200			13.8	2000	2000	1300	770	360	260	
250			17.2	2000	2000	1600	960	450	320	

Outlet Pressure Spring Range	Outlet Pressure Setting	Maximum Allowable Downstream Pressure	Maximum Inlet Pressure to Keep Maximum Allowable Downstream Pressure from Being Exceeded ²							
			R627							
			Port Diameter, inches							
PSIG	BAR	PSIG	BAR	3/32	1/8	3/16	1/4	3/8	1/2	
15 to 40 PSIG (1.0 to 2.8 BAR)	15	1.0	60	4.1	1000	380	210	130	80	65
			100	6.9	2000	1300	590	350	170	120
			125	8.6	2000	1800	800	470	220	160
			175	12.1	2000	2000	1100	640	320	220
			200	13.8	2000	2000	1300	780	370	260
			250	17.2	2000	2000	1600	960	450	320
	20	1.4	60	4.1	630	200	150	100	70	65
			100	6.9	2000	1200	550	330	160	120
			125	8.6	2000	1700	760	450	210	160
			175	12.1	2000	2000	1100	630	320	220
			200	13.8	2000	2000	1300	770	360	260
			250	17.2	2000	2000	1600	960	450	320
	30	2.1	100	6.9	2000	950	450	260	140	110
			125	8.6	2000	1500	670	400	190	150
			175	12.1	2000	2000	1000	610	300	220
			200	13.8	2000	2000	1200	760	360	260
250			17.2	2000	2000	1600	970	450	320	
40			2.8	100	6.9	1500	700	330	200	120
	125	8.6		2000	1300	560	340	180	140	
	175	12.1		2000	1800	1000	550	290	220	
	200	13.8		2000	2000	1200	730	350	250	
	250	17.2		2000	2000	1600	970	460	320	

1. The internal relief performance values are obtained by removing the disk assembly.
 2. For inlet pressure in excess of 1000 PSIG (69.0 BAR) refer to the maximum body and disk pressure ratings in the specifications section.
 3. For pressure settings under 10 PSIG (0.69 BAR) inlet pressure should be limited to approximately 100 PSIG (6.90 BAR) so the set point adjustment can be obtained.
 4. Shaded areas indicate maximum inlet pressures allowed during system failure only.

R627 Internal Relief Performance¹

Outlet Pressure Spring Range	Outlet Pressure Setting		Maximum Allowable Downstream Pressure		Maximum Inlet Pressure to Keep Maximum Allowable Downstream Pressure from Being Exceeded ²					
					R627					
					Port Diameter, inches					
PSIG	BAR	PSIG	BAR	3/32	1/8	3/16	1/4	3/8	1/2	
35 to 80 PSIG (2.4 to 5.5 BAR)	40	2.8	125	8.6	2000	1100	500	300	170	140
			150	10.3	2000	1600	750	440	230	180
			175	12.1	2000	2000	980	580	290	220
			200	13.8	2000	2000	1200	720	340	250
			250	17.2	2000	2000	1600	940	450	320
	50	3.4	125	8.6	1400	820	400	230	150	140
			150	10.3	2000	1400	650	370	210	170
			175	12.1	2000	1900	700	530	270	210
			200	13.8	2000	2000	1100	670	330	240
			250	17.2	2000	2000	1500	920	430	320
	60	4.1	125	8.6	900	450	270	190	140	130
			150	10.3	1700	1100	540	300	190	160
			175	12.1	2000	1700	780	470	250	200
			200	13.8	2000	2000	1000	610	310	230
			250	17.2	2000	2000	1400	880	420	310
	70	4.8	150	10.3	1200	850	430	250	170	160
			175	12.1	2000	1400	670	400	230	190
			200	13.8	2000	2000	920	550	280	230
			250	17.2	2000	2000	1300	830	400	310
			150	10.3	800	500	300	200	160	150
80	5.5	175	12.1	1500	1200	550	330	210	190	
		200	13.8	2000	1700	800	480	270	220	
		250	17.2	2000	2000	1200	770	390	300	
		175	12.1	1900	600	400	260	200	175	
		200	13.8	2000	1200	630	380	250	210	
70 to 150 PSIG (4.8 to 10.3 BAR)	70	4.8	250	17.2	2000	2000	1100	680	360	290
			175	12.1	1400	250	240	200	190	175
			200	13.8	2000	960	250	330	240	210
	80	5.5	250	17.2	2000	2000	1000	620	350	280
			200	13.8	1500	250	240	230	210	210
			250	17.2	2000	1600	770	520	320	270
	125	8.6	250	17.2	2000	1000	500	390	290	260
	150	10.3	250	17.2	1200	260	260	260	260	260

- The internal relief performance values are obtained by removing the disk assembly.
- For inlet pressure in excess of 1000 PSIG (69.0 BAR) refer to the maximum body and disk pressure ratings in the specifications section.
- For pressure settings under 10 PSIG (0.69 BAR) inlet pressure should be limited to approximately 100 PSIG (6.90 BAR) so the set point adjustment can be obtained.
- Shaded areas indicate maximum inlet pressures allowed during system failure only.

R627 Capacities for 3/4-inch Body Size¹

Outlet Pressure Spring Range	Outlet Pressure Setting		Inlet Pressure		Capacities in SCFH (Nm ³ /h) of 0.6 Specific Gravity Natural Gas 3/4" Body Size					
					Orifice Size, Inches					
					3/32	1/8	3/16	1/4	3/8	1/2
5 to 20 PSIG ² (.03 to 1.4 BAR)	5	0.3	10	0.7	170	320	710	1050	1500	1850
			15	1.0	240	330	810	1290	2100	2850
			20	1.4	290	460	1090	1750	2750	3850
			30	2.1	380	610	1470	2490	3600	4800
			60	4.1	640	1170	2460	3690	5270	6120
	10	0.7	75	5.2	770	1410	2880	4150	5760	6900
			100	6.9	990	1690	3540	4790	6200	7600
			15	1.0	210	320	800	1290	2100	2820
			20	1.4	280	450	1070	1740	2700	3800
			30	2.1	380	610	1470	2430	3550	4780
			60	4.1	640	1170	2460	3690	5270	6120
			75	5.2	770	1410	2880	4150	5760	6900
			100	6.9	990	1690	3540	4790	6200	7600
			150	10.3	1420	2430	4000	5680	6250	7630
			200	13.8	1850	3070	4200	6200	6380	7680
	20	1.4	300	20.7	2700	3970	4270	6250	6500	
			500	34.5	4010	4240	5640	6520		
			750	51.7	4400	5120	6400			
			1000	69.0	4450	6220				
			1250	86.2	4540					
1500			103	4880						
1750			121	5230						
2000			138	5900						
30			2.1	350	590	1390	2480	4350	4970	
50			3.5	550	980	2240	4000	7450	8000	
60	4.1	640	1170	2610	4680	7800	8900			
100	6.9	990	1800	3980	6700	9750	10400			
150	10.3	1420	2580	5600	8790	10000	10800			
200	13.8	1850	3370	7050	9000	10200	10800			
300	20.7	2700	4910	7300	9500	10500				
500	34.5	4400	5200	7400	9760					
750	51.7	6600	5360	8870						
1000	69.0	7300	6500							
1250	86.2	7500								
1500	130	7800								
1750	121	8400								
2000	138	8600								
15 to 40 PSIG (1.0 to 2.8 BAR)	40	2.8	60	4.1	610	1090	2270	4230	8100	9100
			75	5.2	760	1370	3080	5330	10300	11600
			100	6.9	990	1790	4070	6840	11900	13400
	150	10.3	1420	2580	5850	9320	13500	13800		
	200	13.8	1850	3370	7630	11000	16300	17100		
	300	20.7	2700	4910	11200	14700	17800			
	500	34.5	4400	8090	14500	14800				
	750	51.7	6600	10800	14800	14900				
	1000	69.0	8700	13100	16300					
	1250	86.2	11000	13800						
	1500	130	12000	14000						
	1750	121	13000							
2000	138	14000								
35 to 80 PSIG (2.4 to 5.5 BAR)	60	4.1	75	5.2	700	1230	2760	4700	8170	12600
			100	6.9	970	1740	3910	6690	11900	14400
			150	10.3	1420	2580	5850	9740	15700	18700
			200	13.8	1850	3370	7630	12400	18400	21200
			300	20.7	2700	4910	11200	17700	20200	
			500	34.5	4400	8090	18300	20000		
			750	51.7	6600	12000	18900	21400		
			1000	69.0	8700	16000	19000			
			1250	86.2	11000	18700				
			1500	130	13000	19000				
			1750	121	15000	20000				
			2000	138	17000					

Table Continued

- Capacity is based on 20% droop unless otherwise noted below.
- For pressure setting under 10 PSIG (0.69 BAR) inlet pressure should be limited to approximately 100 PSIG (6.90 BAR) so that setpoint adjustment can be obtained.
- Blank areas indicate where maximum operating inlet pressure for a given orifice is exceeded.

R627 Capacities for 3/4-inch Body Size¹

Outlet Pressure Spring Range	Outlet Pressure Setting		Inlet Pressure		Capacities in SCFH (Nm ³ /h) of 0.6 Specific Gravity Natural Gas 3/4" Body Size							
					Orifice Size, Inches							
	PSIG	BAR	PSIG	BAR	3/32	1/8	3/16	1/4	3/8	1/2		
35 to 80 PSIG (2.4 to 5.5 BAR)	80	5.5	100	6.90	900	1630	3570	6490	12000	17200		
			150	10.3	1410	2580	5780	10500	18900	25000		
			200	13.8	1850	3370	7630	13700	23000	29000		
			300	20.7	2700	4910	11200	20100	26000			
			500	34.5	4400	8090	18300	29000				
			750	51.7	6600	12000	23100	30900				
			1000	69.0	8700	16000	27400					
			1250	86.2	11000	19000						
			1500	130	13000	22000						
			1750	121	15000	25000						
			2000	138	17000							
			70 to 150 PSIG (4.8 to 10.3 BAR)	100	6.9	150	10.3	1170	2510	5540	8310	15500
200	13.8	1850				3370	7630	12000	20100	25700		
300	20.7	2700				4910	11200	18200				
500	34.5	4400				8090	18300					
750	51.7	6600				12000						
1000	69.0	8700				16000						
1250	86.2	11000										
1500	130	13000										
1750	121	15000										
2000	138	17000										
125	8.6	150				10.3	1250	2330	5090	9130	15700	20800
		200				13.8	1830	3320	7360	13160	22400	28600
		300		20.7	2700	4910	11200	19700				
		500		34.5	4400	8090	18300					
		750		51.7	6600	12000						
		1000		69.0	8700	16000						
		1250		86.2	11000							
		1500		130	13000							
		1750		121	15000							
		2000		138	17000							
		150		10.3	200	13.8	1760	3200	7020	12500	21400	30600
					300	20.7	2700	4910	11200	17200		
500	34.5				4400	8090	18300					
750	51.7				6600	12000						
1000	69.0		8700		16000							
1250	86.2		11000									
1500	130		13000									
1750	121		15000									
2000	138		17000									

1. Capacity is based on 20% droop unless otherwise noted below.
2. For pressure setting under 10 PSIG (06.9 BAR) inlet pressure should be limited to approximately 100 PSIG (6.90 BAR) so that setpoint adjustment can be obtained.
3. [Blank] - Blank areas indicate where maximum operating inlet pressure for a given orifice is exceeded.

R627 Capacities for 1 and 2 Inch Body Sizes¹

Outlet Pressure Spring Range	Outlet Pressure Setting		Inlet Pressure		Capacities in SCFH (Nm ³ /h) of 0.6 Specific Gravity Natural Gas 1 & 2" Body Size						
					Orifice Size, Inches						
	PSIG	BAR	PSIG	BAR	3/32	1/8	3/16	1/4	3/8	1/2	
5 to 20 PSIG ² (.03 to 1.4 BAR)	5	0.3	10	0.7	170	330	710	1080	2000	2150	
			15	1.0	240	390	890	1500	2350	3000	
			20	1.4	290	500	1160	1900	2750	3900	
			30	2.0	380	690	1500	2500	3600	4900	
			60	4.1	640	1170	2460	3690	5650	6900	
			75	5.2	770	1410	2880	4150	6450	7490	
			100	6.9	990	1800	3540	5790	7520	8150	
			15	1.0	210	390	840	1480	2300	2930	
			20	1.4	280	500	1100	1880	2700	3830	
			30	2.0	380	690	1500	2460	3550	4840	
			60	4.1	640	1170	2460	3690	5650	6900	
			75	5.2	770	1410	2880	4150	6450	7490	
	100	6.9	990	1800	3540	4790	7520	8150			
	150	10.3	1420	2580	4660	5680	9980	10800			
	200	13.8	1850	3370	5620	6360	11000	12900			
	300	20.7	2700	4880	6890	7780	13600				
	500	34.5	4400	6720	8570	11600					
	750	51.7	5400	8850	9000						
	1000	69.0	5800	9500							
	1250	86.2	6300								
	1500	103	6600								
	1750	121	6800								
	2000	138	7600								
	20	1.4	30	2.07	350	600	1390	2580	4350	6290	
50			3.45	550	1000	2250	4090	7600	8000		
60			4.14	640	1170	2630	4750	7800	10600		
100			6.90	990	1800	4070	7310	10800	13400		
150			10.3	1420	2580	5720	10300	13500	14000		
200			13.8	1850	3370	7050	10500	14000	14000		
300			20.7	2700	4910	9250	10800	14900			
500			34.5	4400	7830	11800	13000				
750			51.7	6600	9000	12000					
1000			69.0	8700	9660						
1250			86.2	10000							
1500			103	10400							
1750	121	12000									
2000	138	14000									
15 to 40 PSIG (1.0 to 2.8 BAR)	40	2.8	60	4.1	610	1090	2430	4510	9200	9400	
			75	5.2	760	1370	3080	5640	10800	16300	
			100	6.9	990	1790	4070	7310	13500	17600	
			150	10.3	1420	2580	5850	10500	18000	22200	
			200	13.8	1850	3370	7630	11000	21400	24600	
			300	20.7	2700	4910	11200	14900	24400		
			500	34.5	4400	8090	16300	21800			
			750	51.7	6600	12000	20200	23600			
			1000	69.0	8700	16000	23200				
			1250	86.2	11000	19000					
			1500	103	13000	21000					
			1750	121	15000						
2000	138	17000									
35 to 80 PSIG (2.4 to 5.5 BAR)	60	4.1	75	5.2	700	1230	2760	4860	8600	12800	
			100	6.9	970	1740	3910	7000	12500	16700	
			150	10.3	1420	2580	5850	10500	16800	2300	
			200	13.8	1850	3370	7630	13700	20900	27700	
			300	20.7	2700	4910	11200	20100	28100		
			500	34.5	4400	8090	18300	28500			
			750	51.7	6600	12000	22800	29500			
			1000	69.0	8700	16000	26800				
			1250	86.2	11000	19000					
			1500	103	13000	22000					
			1750	121	15000	25000					
			2000	138	17000						

Table Continued

1. Capacity is based on 20% droop unless otherwise noted below.
2. For pressure setting under 10 PSIG (06.9 BAR) inlet pressure should be limited to approximately 100 PSIF (6.90 BAR) so that setpoint adjustment can be obtained.
3. [Blank] - Blank areas indicate where maximum operating inlet pressure for a given orifice is exceeded.

R627 Capacities for 1 and 2 Inch Body Sizes¹

Outlet Pressure Spring Range	Outlet Pressure Setting		Inlet Pressure		Capacities in SCFH (Nm ³ /h) of 0.6 Specific Gravity Natural Gas 1 & 2" Body Size						
					Orifice Size, Inches						
	PSIG	BAR	PSIG	BAR	3/32	1/8	3/16	1/4	3/8	1/2	
35 to 80 PSIG (2.4 to 5.5 BAR)	80	5.5	100	6.9	900	1630	3570	6650	12000	17400	
			150	10.3	1410	2580	5750	10500	20100	26000	
			200	13.8	1850	3370	7630	13700	25100	31800	
			300	20.7	2700	4910	11200	20100	32600		
			500	34.5	4400	8090	18300	30300			
			750	51.7	6600	12000	27200	37400			
			1000	69.0	8700	16000	33300				
			1250	86.2	11000	19000					
			1500	103	13000	22000					
			1750	121	15000	25000					
2000	138	17000									
70 to 100 PSIG (4.8 to 6.9 BAR)	100	6.9	150	10.3	1170	2510	5540	8310	15500	20300	
			200	13.8	1850	3370	7630	12000	20100	26700	
			300	20.7	2700	4910	11200	18200			
			500	34.5	4400	8090	18300				
			750	51.7	6600	12000					
			1000	69.0	8700	16000					
			1250	86.2	11000						
			1500	103	13000						
			1750	121	15000						
			2000	138	17000						
70 to 150 PSIG (4.8 to 10.3 BAR)	125	8.6	150	10.3	1250	2330	5090	9470	15700	20800	
			200	13.8	1830	3320	7360	13400	23600	31300	
			300	20.7	2700	4910	11200	19700			
			500	34.5	4400	8090	18300				
			750	51.7	6600	12000					
			1000	69.0	8700	16000					
			1250	86.2	11000						
			1500	103	13000						
			1750	121	15000						
			2000	138	17000						
150 to 200 PSIG (10.3 to 13.8 BAR)	150	10.3	200	13.8	1760	3200	7020	12900	21400	33300	
			300	20.7	2700	4910	11200	17200			
			500	34.5	4400	8090	18300				
			750	51.7	6600	12000					
			1000	69.0	8700	16000					
			1250	86.2	11000						
			1500	103	13000						
			1750	121	15000						
2000	138	17000									

1. Capacity is based on 20% droop unless otherwise noted below.
 [Blank area] - Blank areas indicate where maximum operating inlet pressure for a given orifice is exceeded.

R627 Parts

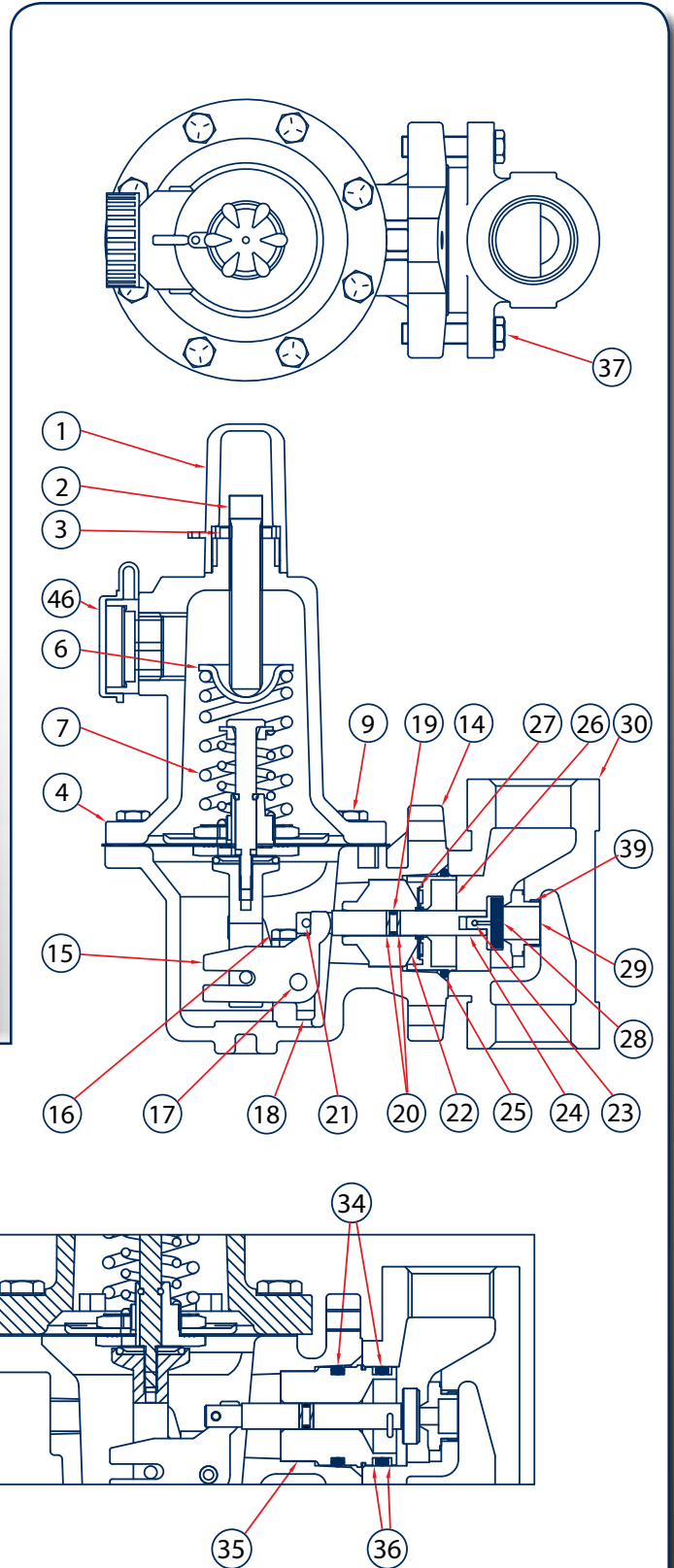

R627 Parts

Item	Description	Qty.	Part Number
1	Cover Adj. Screw, Plastic	1	610-053-000
2	Adjustment Screw	1	648-520-000
3	Locknut	1	634-154-000
4	Bonnet, R627 - Aluminum	1	604-210-000
	Bonnet, R627M - Steel		604-211-000
	Bonnet, R627 - Stainless		604-266-000
5	Vent Screw Assembly	1	836-005-000
6	Spring Guide, Upper	1	626-079-000
7	Range Spring	1	
	5-20 PSIG-Yellow		655-661-000
	15-40 PSIG-Green		655-661-001
	35-80 PSIG & 10-95-PSIG Blue		655-661-002
	70-150 PSIG-Red		655-661-003
	140-250 PSIG-Blue		655-661-002
	240-500 PSIG-Red		655-661-003
8	Spring Guide, Lower (R627 or R627M only)	1	626-101-000
9	Al Spring Case Screws - R627	8	648-466-000
	Stl Spring Case Screws - R627 or R627M		648-467-003
	SS Spring Case Screws - R627 or R627M		648-550-000
10	Diaphragm Piston (R627 or R627M only)	1	637-322-000
11	Diaphragm R627 & R627M Aluminum / Iron Case	1	618-079-000
	Diaphragm R627 & R627M Steel Case		618-080-000
	Diaphragm R627 & R627M Al / Iron (Fluoro)		618-080-001
	Diaphragm R627 & R627M Steel (Fluoro)		618-079-001
12	Diaphragm Retainer	1	648-521-000
13	Post, Pusher R627 & R627M Assy	1	827-011-000
14	Diaphragm Case R627 - Aluminum	1	629-202-000
	Diaphragm Case R627 - Steel		629-203-000
	Diaphragm Case R627M - Steel		629-204-000
	Diaphragm Case, Aluminum (for Steel Body)		629-215-000
	Diaphragm Case R627 - Stainless		629-242-000
	Diaphragm Case R627M - Stainless		629-243-000
15	Lever	1	703-004-000
	Lever, NACE		703-005-000
16	Lever Screw	2	648-466-002
	Lever Screw, NACE		648-474-000
17	Pin, Lever	1	635-053-000
	Pin, Lever, NACE		635-057-000
18	Lever Retainer	1	643-192-000
	Lever Retainer, NACE		643-194-000
19	Stem O-ring, Nitrile	1	649-000-003
20	Stem Backup Ring, TFE	2	644-047-000
21	Pin, Groove	1	635-054-000
	Pin, Groove NACE		635-058-000
22	Stem Guide	1	626-083-000
23	Pin Clip	1	635-055-000
	Pin Clip NACE		635-056-000
24	Stem, 316SS	1	689-005-000
25	Diaphragm Case O-ring, Nitrile (R627 & R627H)	1	649-280-000
26	Boost Body R627	1	686-004-000
27	Stabilizer, Nitrile R627	1	649-278-000
	Stabilizer, Fluorocarbon R627		649-278-001

Item	Description	Qty.	Part Number
28	Seat assembly - Aluminum holder/nitrile disk	1	822-019-000
	Seat assembly - Aluminum/nylon		822-019-001
	Seat assembly - Aluminum/Fluorocarbon		822-040-000
	Seat assembly - 316SS Holder/Nitrile		822-020-000
	Seat assembly - 316SS/Nylon		822-020-001
	Seat assembly - 316SS/Fluorocarbon		822-040-001
29	Orifice - Aluminum - 3/32"	1	688-013-005
	Orifice - Aluminum - 1/8"		688-013-004
	Orifice - Aluminum - 3/16"		688-013-003
	Orifice - Aluminum - 1/4"		688-013-002
	Orifice - Aluminum - 3/8"		688-013-001
	Orifice - Aluminum - 1/2"		688-013-000
	Orifice - 316SS - 3/32"		688-014-005
	Orifice - 316SS - 1/8"		688-014-004
	Orifice - 316SS - 3/16"		688-014-003
	Orifice - 316SS - 1/4"		688-014-002
	Orifice - 316SS - 3/8"		688-014-001
Orifice - 316SS - 1/2"	688-014-000		
30	Iron Body - 3/4 NPT	1	664-280-000
	Iron Body - 1 NPT		664-280-001
	Iron Body - 2 NPT		664-282-000
	Steel Body - 3/4 NPT		664-281-000
	Steel Body - 1 NPT		664-281-001
	Steel Body - 2 NPT		664-283-000
	LCC Body - 3/4 NPT		664-325-000
	LCC Body - 1 NPT LCC		664-325-001
	LCC Body - 2 NPT LCC		664-326-000
	Stainless Body - 3/4 NPT		664-394-000
	Stainless Body - 1 NPT		664-394-001
	Stainless Body - 2 NPT		664-395-000
	Steel - 3/4 NPT Socket Weld		664-356-000
	Steel - 1 NPT Socket Weld		664-358-000
	Steel - 2 NPT Socket Weld		664-359-000
	Stainless - 3/4" Socket Weld		664-422-000
	Stainless - 1" Socket Weld		664-423-000
Stainless - 2" Socket Weld	664-424-000		
31	Nameplate (not shown)	1	632-474-000
32	Relief Spring	1	655-709-000
33	Lower Spring Seat	1	626-102-000
34	O-ring, Throat Block	2	649-281-000
35	Throat Block (R627M only)	1	626-081-000
36	Backup Ring, Throat Block	2	644-048-000
37	Build Screw, 3/4" & 1" Aluminum unit	2	648-466-001
	Build Screw 2" Aluminum unit		648-466-003
	Build Screw, all Steel Bodies		648-467-001
	Build Screw, all Stainless Bodies		648-549-000
38	O-ring	1	649-000-001
40	Name Plate Drive Screw (not shown)	2	648-464-000
41	NACE Tag (not shown)	1	632-503-000
42	Diaphragm Connecting Nut	1	634-182-000
43	Relief Seal Retainer	1	643-198-000
44	Relief Seal O-ring	1	649-308-000
45	Diaphragm Connector	1	650-150-000
46	Relief Cap	1	614-064-000

F627 High Flow Gas Regulator

The F627 pilot operated pressure reducing regulator provides superior performance when used in fixed-factor billing applications. The Type F627 includes a factory-installed PL81 pilot and has external registration that requires a downstream control line.

Features

- **Accurate for Pressure-Factor Measurement Applications** — Pilot action controls pressure to within ± 1 percent of the absolute outlet pressure (PSIA) setting at full travel. This capability results in low-pressure variations over broad flow ranges and inlet pressure ranges.
- **Wide Range of Flow Capabilities** — A variety of body and orifice sizes are available.
- **Tight Shutoff Capability** — A flat disk of nitrile or fluorocarbon provides excellent shutoff capability.



Materials of Construction

F627 Main Regulator	
Body	Ductile Iron (Standard), Steel, LCC Steel
Spring Case and Diaphragm Case	Die Cast Aluminum (standard), or Steel
Orifice	Aluminum (Standard) or Stainless Steel
Disk Assembly	Aluminum (Standard) or Stainless Steel Holder with Nitrile Disk or Fluorocarbon Disk
O-rings and Diaphragm	Nitrile or Fluorocarbon
Tension Spring	Plated Steel
F627 Pilot Regulator	
Body	Aluminum
Spring Case	Aluminum
Diaphragm	Nylon Fabric Coated with Nitrile or Fluorocarbon
Valve Plug	Brass / Nitrile or Fluorocarbon
Stem Guide	Brass
Control Spring	Zinc Plated Steel
Valve Spring Plug	Aluminum
Pusher Post and Valve Plug Spring Seat	Aluminum
Diaphragm Plate, Spring Guide, and Adjusting Screw	Plated Steel

Minimum Pressure Differential

Actuator Spring and (Color Code)	Pilot Control Spring and (Color Code)	
	5 to 35 PSIG (0.34 to 2.41 bar) (Silver)	35 to 100 PSIG (0.34 to 2.41 bar) (Red)
High Differential (Red)	20 PSI (1.38 BAR)	20 PSI (1.38 BAR)

Specifications

Outlet Pressure Ranges		
Outlet	5 to 35 PSIG	0.34 to 2.41 BAR
	35 to 100 PSIG	2.41 to 6.90 BAR
Maximum Outlet (Casing) Pressure	250 PSIG	17.24 BAR
Maximum Inlet Pressure	250 PSIG (17.2 BAR) for all Type F627's EXCEPT 1/2" Orifice is 125 PSIG (8.62 BAR)	
Body Sizes	3/4 NPT (DN 20)	
	1 NPT (DN 25)	
	2 NPT (DN 50)	
Temperature Range	-20° to 180°F	(-29° to 82°C)
Weight Approximate		
NPT Body with Ductile Iron or Steel Casings	13 lbs	5.9 kg
NPT Body with Aluminum Casings	9.3 lbs	4.2 kg
Flanged Body with Ductile Iron Casings	18 lbs	8.16 kg
Flanged Body with Ductile Iron Casings	14 lbs	6.35 kg

F627 Part Matrix

F627								
	↑	↑	↑	↑	↑	↑	↑	Port Size
	06							3/4"
	08							1"
	16							2"
								Spring Range
								PSIG BAR
	035							5 - 35 .34 - 2.4
	100							35 - 100 2.4 - 6.9
								Special Adders
	0							None
	1							Filter & Inlet Tube to Pilot Supply
	A							150 #RF*
	B							300 #RF*
	C							600 #RF*
	D							Socket Weld*
	J							150 #RF* with Filter and Tube
	K							300 #RF* with Filter and Tube
	L							600 #RF* with Filter and Tube
	M							Socket Weld* with Filter and Tube
								Restrictor Code
	1							High Gain
	2							Medium Gain
	3							Low Gain
								Orifice Size
	2							3/8" X 1/8"
	4							3/8" X 1/4"
	6							3/8"
	8							1/2"
								Seat and Diaphragm Material
	0							Nitrile
	2							Fluorocarbon
								Trim
	1							Aluminum (Standard)
	T							Stainless Steel
								Casing Material
	0							Aluminum Casing / Iron Body
	1							Steel Casing / Steel Body
	2							Aluminum Casing / Steel Body
	6							Aluminum Casing / LCC Steel Body
	7							Steel Casing / LCC Steel Body
	8							Steel Casing / Iron Body

* Steel or LCC Steel Bodies Only

F627 Regulator Rebuild Kits

	Kit Includes	Part Number
F627 Nitrile Standard Trim	Nitrile diaphragms (2), Nitrile valve disk, O-rings, back-up rings, and retaining pin	971F62700
F627 Nitrile Stainless Trim	Nitrile diaphragms (2), Nitrile valve disk, O-rings, back-up rings, and retaining pin	971F62701
F627 Fluorocarbon Standard Trim	Fluorocarbon diaphragms (2), Fluorocarbon valve disk, O-rings, back-up rings, and retaining pin	971F62702
F627 Fluorocarbon Stainless Trim	Fluorocarbon diaphragms (2), Fluorocarbon valve disk,, O-rings, back-up rings, and retaining pin	971F62703

F627 Maximum Allowable Inlet Pressure and Pressure Differential

ORIFICE SIZE INCHES (mm)	HIGH DIFFERENTIAL TENSION SPRING, RED COLOR CODE	
	LP Pilot	HP Pilot
	Maximum Inlet and Differential Pressure, PSIG (BAR)	Maximum Inlet and Differential Pressure, PSIG (BAR)
3/8 x 1/8 (9.53 x 3.18)	250 (17.2)	250 (17.2)
3/8 x 1/4 (9.53 x 6.35)	250 (17.2)	250 (17.2)
3/8 (9.53)	250 (17.2)	250 (17.2)
1/2 (12.7)	125 (8.62)	125 (8.62)

F627 Specifications

ORIFICE SIZE		ALLOWABLE INLET PRESSURE RANGE FOR MAINTAINING OUTLET PRESSURE WITHIN 1% OF THE ABSOLUTE OUTLET PRESSURE SETTING ⁽¹⁾									
		5 PSIG (0.34 BAR)		30 PSIG (2.07 BAR)		40 PSIG (2.76 BAR)		60 PSIG (4.14 BAR)		100 PSIG (6.90 BAR)	
Inch	mm	PSIG	BAR	PSIG	BAR	PSIG	BAR	PSIG	BAR	PSIG	BAR
3/8 x 1/8	9.5 x 3.2	30 to 250	2.1 to 6.9	55 to 250	3.8 to 17.2	65 to 250	4.5 to 17.2	85 to 250	5.9 to 17.2	125 to 250	8.6 to 17.2
3/8 x 1/4	9.5 x 6.4	30 to 250	2.1 to 6.9	55 to 250	3.8 to 17.2	65 to 250	4.5 to 17.2	85 to 250	5.9 to 17.2	125 to 250	8.6 to 17.2
3/8	9.5	30 to 250	2.1 to 6.9	55 to 250	3.8 to 17.2	65 to 250	4.5 to 17.2	85 to 250	5.9 to 17.2	125 to 250	8.6 to 17.2
1/2	12.7	25 to 125	1.7 to 8.6	50 to 125	3.4 to 8.6	60 to 125	4.1 to 8.6	80 to 125	5.5 to 8.6	120 to 125	8.3 to 8.6

1. For best performance, outlet pressure settings should be made using an inlet pressure that is midway between the highest and lowest expected inlet pressure.

F627 Flow Coefficients

Orifice Size		3/4-Inch Body			1-Inch Body			2-Inch Body		
Inch	mm	Wide-Open C_v for External Relief Sizing	C_v	C_1	Wide-Open C_v for External Relief Sizing	C_v	C_1	Wide-Open C_v for External Relief Sizing	C_v	C_1
3/8 x 1/8	3.2	12.5	0.43	29.1	12.5	0.45	29.4	12.5	0.45	29.2
3/8 x 1/4	6.4	50	1.63	30.6	50	1.70	29.3	52	1.70	31.3
3/8	9.5	108	3.00	36.1	108	3.70	31.6	115	3.40	33.9
1/2	12.7	190	4.80	39.0	190	5.30	35.9	200	5.30	39.9

Typical Performance Curve for 3/4-inch (DN 20) Type F627 Regulator

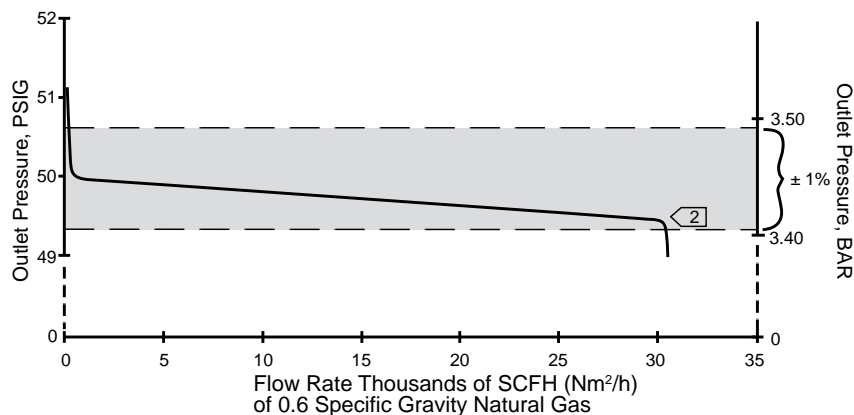

2 3/8-Inch (9.52 mm) Orifice.
 (Red Color Code) Actuator Spring 35 to 100 PSIG
 (2.41 to 6.90 BAR) Range (Red Color Code)
 Pilot Spring 200 PSIG Inlet Pressure (13.8 BAR) Inlet Pressure
 Medium Gain Restrictor

F627 Flow Capacities in SCFH (Nm³/h) of 0.6 Specific Gravity Natural Gas at 1% Droop in Absolute

Pilot Spring Range Part Number Color Code	Outlet Pressure Setting		Inlet Pressure		3/4" (DN 20) Body Size				1" Body Size				2" Body Size					
	PSIG	BAR	PSIG	BAR	Orifice Diameter, inches				Orifice Diameter, inches				Orifice Diameter, inches					
					3/8 x 1/8 (9.52 x 3.18)	3/8 x 1/4 (9.53 x 6.35)	3/8 (9.53)	1/2 (12.7)	3/8 x 1/8 (9.52 x 3.18)	3/8 x 1/4 (9.53 x 6.35)	3/8 (9.53)	1/2 (12.7)	3/8 x 1/8 (9.52 x 3.18)	3/8 x 1/4 (9.53 x 6.35)	3/8 (9.53)	1/2 (12.7)		
5 to 35 PSIG (0.34 to 2.41 BAR) 655000154 Green	5	0.34	30	2.07	700	2840	5780	9730	700	2840	6040	10,100	700	2840	6150	10,100		
			40	2.76	660	3500	7480	13,100	860	3500	7480	13,100	860	3500	7760	13,800		
			50	3.45	1020	4140	8850	15,400	1020	4140	8850	15,400	1020	4140	9180	16,300		
			60	4.14	1170	4780	10,200	15,500	1170	4780	10,200	17,800	1170	4780	10,600	18,800		
			80	5.52	1490	6060	12,900	15,500	1490	6060	12,900	18,500	1490	6060	13,400	23,800		
			100	6.90	1800	7340	15,500	15,500	1800	7340	15,700	18,500	1800	7340	16,300	28,900		
			125	8.62	2200	8940	15,500	15,500	2200	8940	18,500	18,500	2200	8940	19,800	30,000		
			150	10.3	2560	10,500	15,500		2590	10,500	18,500		2580	10,500	23,400			
			200	13.6	3370	13,700	15,500		3370	13,700	18,500		3370	13,700	30,000			
			250	17.2	4170	15,500	15,500		4170	15,500	18,500		4170	15,500	30,000			
	10	0.69	30	2.07	690	2760	5480	8500	690	2760	5480	8930	690	2760	5840	9500		
			40	2.76	860	3500	7480	13,100	860	3500	7480	13,100	860	3500	7760	13,800		
			50	3.45	1020	4140	8850	15,400	1020	4140	8850	15,400	1020	4140	9180	16,300		
			60	4.14	1170	4780	10,200	17,800	1170	4780	10,200	17,800	1170	4780	10,600	18,800		
			80	5.52	1490	6060	12,900	19,500	1490	6060	12,900	22,400	1490	6060	13,400	23,800		
			100	6.90	1800	7340	15,700	19,500	1800	7340	15,700	22,600	1800	7340	16,300	28,900		
			125	8.62	2200	8940	17,500	19,500	2200	8940	19,100	22,600	2200	8940	19,800	35,100		
			150	10.3	2580	10,500	19,500		2580	10,500	22,500		2580	10,500	23,400			
			200	13.8	3370	13,700	19,500		3370	13,700	22,600		3370	13,700	30,500			
			250	17.2	4170	16,900	19,500		4170	16,900	22,600		4170	16,900	37,600			
	20	1.38	40	2.76	820	3250	6320	10,000	820	3250	6830	10,500	820	3250	6830	10,900		
			50	3.45	1000	4030	8010	13,400	1000	4030	8500	13,400	1000	4030	8570	13,900		
			60	4.14	1170	4780	10,200	17,800	1170	4780	10,200	17,800	1170	4780	10,600	18,800		
			80	5.52	1490	6060	12,900	22,600	1490	6060	12,900	22,600	1490	6060	13,400	23,800		
			100	6.90	1800	7340	15,700	24,000	1800	7340	15,700	27,400	1800	7340	16,300	28,900		
			125	8.62	2200	8940	19,100	28,000	2200	8940	19,100	33,300	2200	8940	19,800	35,100		
			150	10.3	2580	10,500	22,500		2580	10,500	22,500		2580	10,500	23,400			
			200	13.8	3370	13,700	28,000		3370	13,700	29,400		3370	13,700	30,500			
250			17.2	4170	16,900	28,000		4170	16,900	33,300		4170	16,900	37,600				
30			2.07	50	3.45	930	3680	7090	11,000	930	3650	7670	11,700	930	3630	7670	11,700	
	60	4.14		1140	4530	8880	14,800	1140	4530	9540	15,300	1140	4530	9540	15,300			
	80	5.52		1490	6060	12,900	22,600	1490	6060	12,900	22,600	1490	6060	13,500	23,800			
	100	6.90		1800	7340	15,700	27,400	1800	7340	15,700	27,400	1800	7340	16,300	28,900			
	125	8.62		2200	8940	19,100	33,300	2200	8940	19,100	33,300	2200	8940	19,800	35,100			
	150	10.3		2580	10,500	22,500		2580	10,500	22,500		2580	10,500	23,400				
	200	13.8		3370	13,700	28,000		3370	13,700	29,400		3370	13,700	30,500				
	250	17.2		4170	16,900	28,000		4170	16,900	36,200		4170	16,900	37,600				
	35 to 100 PSIG (2.41 to 6.90 BAR) 655000155 Red	40		2.76	60	4.14	1030	4070	7770	10,400	1030	4070	8530	11,000	1030	4070	8440	12,000
					80	5.52	1450	5790	11,400	19,000	1450	5790	12,200	19,700	1450	5790	12,200	19,700
100			6.90		1790	7340	15,700	27,400	1790	7340	15,700	27,400	1790	7340	16,300	28,900		
125			8.62		2200	8940	19,100	33,300	2200	8940	19,100	33,300	2200	8940	19,800	35,100		
150			10.3		2580	10,400	20,000		2560	10,400	22,500		2580	10,400	23,400			
200			13.8		3370	13,500	20,000		3370	13,500	29,400		3370	13,500	30,500			
250			17.2		4170	16,900	20,000		4170	16,900	36,200		4170	16,900	37,600			
50			3.45		70	4.83	1130	4450	8430	10,600	1130	4450	8460	11,200	1130	4450	8460	14,000
		80		5.52	1370	5420	10,500	17,000	1370	5420	11,400	17,900	1370	5420	11,300	17,900		
		100		6.90	1770	7060	14,000	23,000	1770	7060	14,900	24,200	1770	7060	15,000	24,200		
		125		8.62	2200	8940	19,100	33,300	2200	8940	19,100	33,300	2200	8940	19,800	35,100		
		150		10.3	2580	10,400	22,500		2580	10,400	22,500		2590	10,400	23,400			
		200		13.8	3370	13,500	29,000		3370	13,500	29,400		3370	13,500	30,500			
		250		17.2	4170	16,900	29,000		4170	16,900	36,200		4170	16,900	37,600			
		60		4.14	80	5.52	1220	4790	9050	12,000	1220	4790	9860	12,900	1220	4790	9860	14,000
100			6.90		1700	6730	13,100	21,600	1700	6730	14,100	22,400	1700	6730	14,100	22,400		
125			8.62		2170	8700	17,300	28,400	2170	8700	18,400	30,000	2170	8700	18,400	30,000		
150			10.3		2580	10,300	22,500		2580	10,300	22,500		2580	10,300	23,400			
200			13.8		3370	13,500	29,400		3370	13,500	29,400		3370	13,500	30,500			
250			17.2		4170	16,900	32,000		4170	16,900	36,200		4170	16,900	37,600			
75			5.17		100	6.90	1490	5870	11,100	17,000	1490	5870	12,100	18,000	1490	5870	12,100	18,000
					125	8.62	2080	8250	16,000	26,600	2080	8250	16,900	27,600	2080	8250	17,300	27,600
		150		10.3	2550	10,200	20,300		2550	10,200	20,300		2550	10,200	21,700			
		200		13.8	3370	13,500	29,400		3370	13,500	29,400		3370	13,500	30,500			
		250		17.2	4170	16,900	32,000		4170	16,900	36,200		4170	16,900	37,600			
		100		6.90	125	8.62	1660	6680	12,500	18,000	1660	6680	13,700	19,400	1660	6680	13,700	21,200
					150	10.3	2360	9320	17,800		2360	9320	19,400		2360	9320	19,400	
					200	13.8	3330	13,400	26,000		3330	13,400	28,300		3330	13,400	28,500	
250	17.2		4170		16,900	36,000		4170	16,900	36,200		4170	16,900	37,600				

- High Differential Actuator Spring
 - Maximum Operating Inlet Pressure is Exceeded

F627 Dimensions

Aluminum/Cast Ductile Iron Units

Type	Body Size		A	B	C	D	E	F*	K
F627	3/4"	mm	104	254	247	26	3/4"	190	152
		inches	4.08	10.0	9.75	1.0		7.5	6.0
	1"	mm	104	254	247	26	1"	190	152
		inches	4.08	10.0	9.75	1.0		7.5	6.0
	2"	mm	127	267	247	43	2"	216	152
		inches	5.0	10.5	9.75	1.69		8.5	6.0

*F Dimensions for steel P627 - 120 mm / 4.7 inches

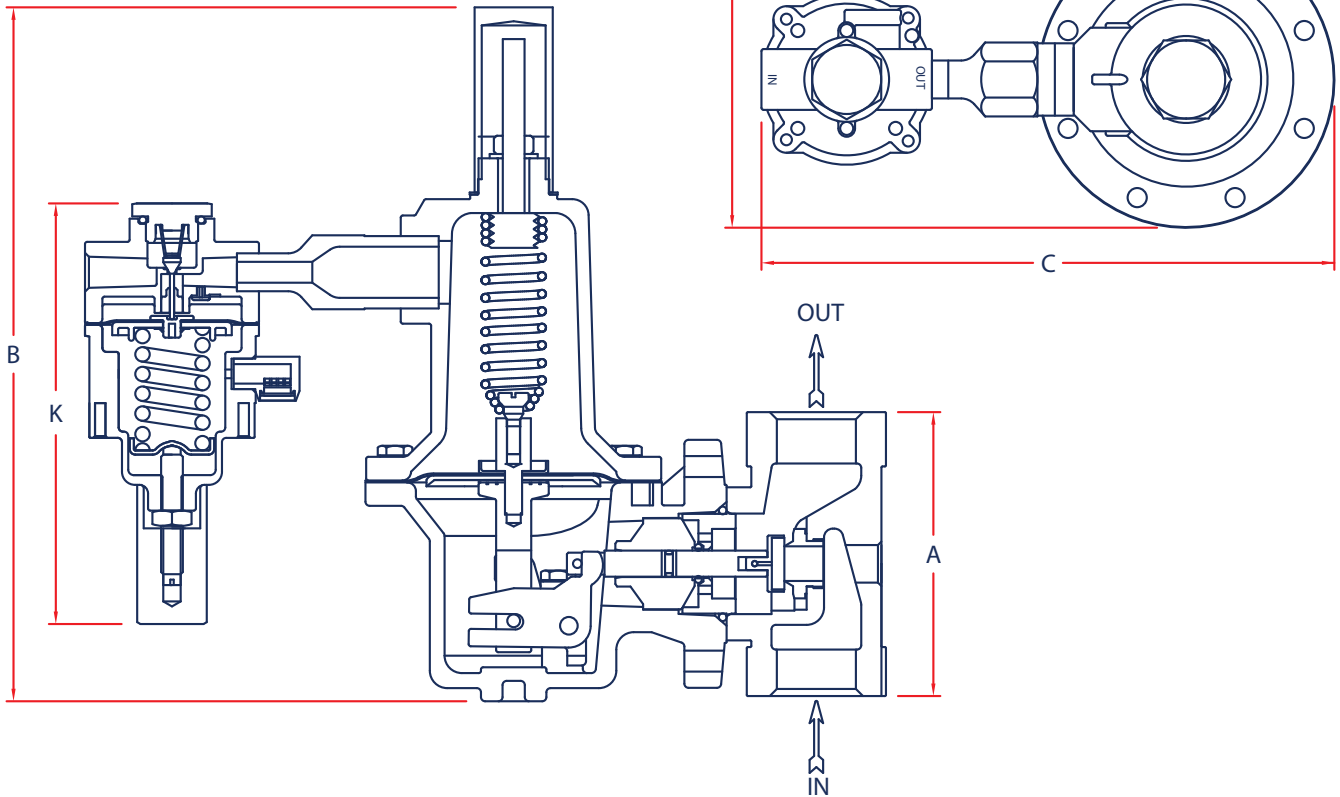

F627 Dimensions

Flange Units

Type	Body Size	A			D			G			H	J			
		150 RF	300 RF	600 RF	150 RF	300 RF	600 RF	150 RF	300 RF	600 RF		Steel	150 RF	300 RF	600 RF
F627 Flanged Units	1"	mm	184	197	210	297	297	297	91.9	98.6	105	168	53.8	62.0	62.0
		in.	7.25	7.75	8.25	11.7	11.7	11.7	3.62	3.88	4.12	6.62	2.12	2.44	2.44
	2"	mm	254	267	286	297	297	297	127	133	143	168	76.2	82.5	82.5
		in.	10	10.5	11.25	11.7	11.7	11.7	5	5.25	5.62	6.62	3	3.25	3.25

F627 Parts

Item	Description	Part Number
1	Closing Cap, Aluminum	610-068-000
32	Closing Cap Gasket	624-082-000
2	Spring Seat Bolt	648-541-000
33	Spring Retainer Screw	648-542-000
3	Locknut	634-000-112
4	Bonnet, F627 - Aluminum	604-210-000
	Bonnet, F627 - Steel	604-561-000
7	Tension Spring	655-745-000
8	Diaphragm Piston	637-306-000
	Diaphragm Standoff	637-020-000
	Diaphragm Nylon Gasket	624-083-000
	Piston Retainer	643-191-000
	Post, Pusher F627	827-005-000
	Diaphragms	
	Diaphragm F627 Aluminum (Nitrile)	618-069-000
	Diaphragm F627 Aluminum (Fluorocarbon)	618-069-001
	Diaphragm F627 Steel (Nitrile)	618-070-000
	Diaphragm F627 Steel (Fluorocarbon)	618-096-000
9	Build Screw, Spring Case - Aluminum (8 required)	648-466-000
	Build Screw, Steel (8 required)	648-467-003
10	Diaphragm Cases	
	Diaphragm Case - Aluminum	629-202-000
	Diaphragm Case, Aluminum (for Steel body)	629-215-000
	Diaphragm Case, Steel	629-203-000
11	Lever	703-004-000
12	Lever Screw (2 required)	648-466-002
13	Pin, Lever	635-053-000
14	Lever Retainer	643-192-000
15	Stem O-ring, Nitrile	649-000-003
	Stem O-ring, Fluorocarbon	649-000-343
16	Stem Backup Ring, TFE (2 required)	644-047-000
17	Pin, Groove	635-054-000
18	Stem Guide	626-083-000
19	Pin Clip	635-055-000
20	Stem, 316SS	689-005-000
30	Diaphragm Case O-ring, Nitrile	649-280-000
	Diaphragm Case O-ring, Fluorocarbon	649-280-001
21	Boost Body F627	686-005-000
22	O-ring - Nitrile	649-000-213
	O-ring - Fluorocarbon	010-380-003
23	Seat Assemblies	
	Seat assembly - aluminum holder/nitrile disk	822-019-000
	Seat assembly - aluminum/Fluorocarbon	822-040-000
	Seat assembly - 316SS holder/nitrile	822-020-000
	Seat assembly - 316SS/Fluorocarbon	822-040-001
24	Orifice - Aluminum	
	3/8" x 1/8"	688-059-001
	3/8" x 1/4"	688-059-000
	3/8"	688-013-001
	1/2"	688-013-000
	Orifice - 316SS	
	3/8" x 1/8"	688-060-001
	3/8" x 1/4"	688-060-000
	3/8"	688-014-001
	1/2"	688-014-000

Item	Description	Part Number
25	Bodies	
	Iron - 3/4" NPT	664-560-000
	Iron - 1" NPT	664-560-001
	Iron - 2" NPT	664-563-000
	Steel - 3/4" NPT	664-559-000
	Steel - 1" NPT	664-559-001
	Steel - 2" NPT	664-564-000
	LCC - 3/4" NPT	664-569-000
	LCC - 1" NPT	664-569-001
	LCC - 2" NPT	664-565-000
	Steel - 3/4" Socket Weld	664-566-000
	Steel - 1" Socket Weld	664-567-000
	Steel - 2" Socket Weld	664-568-000
27 (Not Shown)	Build Screw, 3/4" & 1" aluminum unit	648-466-001
	Build Screw, all steel bodies	648-467-001
	Build Screw 2" aluminum unit (2 required)*	648-466-003
28	Name Plate Drive Screw (2 required) (not shown)	648-464-000
34	Bonnet/Pilot Reducing Nipple	633-023-000
29	Locking Nut	662-000-016
5	Locking Washer	662-000-152
6	PL81 Pilot Regulators	
	LP Standard Gain - Nitrile	832-032-000
	LP Low Gain - Nitrile	832-032-001
	LP High Gain - Nitrile	832-032-002
	LP Standard Gain - Fluorocarbon	832-032-003
	LP Low Gain - Fluorocarbon	832-032-004
	LP High Gain - Fluorocarbon	832-032-005
	HP Standard Gain - Nitrile	832-032-006
	HP Low Gain - Nitrile	832-032-007
	HP High Gain - Nitrile	832-032-008
	HP Standard Gain - Fluorocarbon	832-032-009
HP Low Gain - Fluorocarbon	832-032-010	
HP High Gain - Fluorocarbon	832-032-011	

F627 Parts

